



## Application Note

### Residual pressure relief valve operation with EX245-FPSx PROFIsafe SI unit

PRODUCT NAME

SI Unit

MODEL / Series

*EX245-FPS#*

PRODUCT NAME

Monitored dump valve

MODEL / Series

*VP#4#(R)-X536*

*VP#44(R)-X538,X555*

*VP#42R-X562, VP#44R-X563*

*VP544R-X575,X577*

*VP#44(R)-X585,X596,X597*

*VP542-X617*

*VP#46(R)-S,D*

*VG342(R)-X87*

## Contents

1. Purpose.....	2
2. Related documents .....	2
3. For your safety .....	3
4. Diagnostics.....	5
4-1. VP/VG Diagnostics .....	5
4-2. EX245-FPS# Diagnostics .....	6
5. Timing Chart.....	6
6. Electric wiring examples.....	7
6-1. Safety outputs (Zone1 to Zone3) with diagnostic (2 safety inputs) .....	7
6-2. Safety output (Zone M) with diagnostics (2 safety inputs) .....	8
6-3. Safety outputs (Zone1 to Zone3) with diagnostic (1 safety input) .....	10
6-4. Safety outputs (Zone M) with diagnostic (1 Safety input) .....	11
7. Safety relevant data .....	12

**The English version of the Application note (EX##-OMZ0002) is the original. Application notes that have been translated into other languages should be reference only.**

**1. Purpose**

This application note describes the options for wiring the VP/VG series of residual pressure relief valves to the EX245-FPSx PROFIsafe SI unit and associated valve manifold.

**2. Related documents**

Table 1 Related documents

No.	Document No.	Description
1	EX##-OMY0004	Operation manual for EX245-FPS#
2	VP500-TFS16EN	Instruction manual for Series VP#44(R)-X555 VP#44-X597
3	VP500-TFP16EN	Instruction manual for Series VP#4#(R)-X536 VP#44(R)-X538 VP#42R-X562 VP#44R-X563 VP544R-X575 VP544R-X577 VP#46(R)-X596 VP542-X617
4	VP500-TFT25EN	Instruction manual for Series VP#44(R)-X585
5	VP-SMY116EN	Instruction manual for Series VP#46(R)-S,D
6	VG342(R)-TFN31EN	Instruction manual for Series VG342(R)-X87
7	S11-111	Catalogue for VP/VG

The latest versions of these document should be obtained from [www.smcworld.com](http://www.smcworld.com) and/or [www.smc.eu](http://www.smc.eu) and studied by the competent engineer before implementing any solutions using these products.

### **3. For your safety**

The VG/VP series of residual pressure relief valves can achieve Cat.4 of EN ISO13849-1 by using an appropriate safety controller. Refer to table 2 to see the achievable categories for each model of valve.

EX245-FPS # can achieve the safety levels shown in Table 3 Maximum achievable SIL/SILCL/Cat./PL. Refer to the EX245-FPSx manual for the full details.

Installations that are not in accordance with the requirements of the respective manuals will not meet the levels of safety stated in table 3.

In the context of the use of the PROFIsafe system with residual pressure relief valves, the following operations must only be carried out by qualified personnel:

- Planning
- Configuration, parameterization, programming
- Installation, start-up, servicing
- Maintenance, decommissioning

In order to ensure the required safety performance is met, your attention is drawn to Appendix E: Checklists of the Operation manual for EX245-FPS#

Table 2 Achievable category by type of valve

No.	Product series	Category under EN ISO 13849-1:2015
1	VP#4#-X536	2
2	VP#46-S	2
3	VP#4#-X538	3,4
4	VP#4#-X555	3,4
5	VP#46-D	3,4
6	VG342-X87	3,4

Table 3 Maximum achievable SIL/SILCL/Cat./PL

Connection to the F connectors		Input							
		Single-channel sensor or redundant sensor			Two-channel redundant controlling device/sensor				
Input signal		-	-	-	Equivalent			Non-equivalent	
Cross-circuit detection		With	Without		With	Without		With	Without
Sensor: Contact type		Yes	Yes	-	Yes	Yes	-	Yes	Yes
Sensor: OSSD output type		No	-	Yes	No	-	Yes	No	No
Achievable safety requirement	SIL	2	2	2	3	3	3	3	3
	SIL CL	2	2	2	3	3	3	3	3
	Cat.	3*	2	2	4	3	4**	4	3
	PL	d	d	d	e	d	e	e	d

\* Cat. 3 can only be achieved with a redundant sensor (2 series NO contacts) and a connecting cable that meets the fault exclusion requirement of EN13849-2.

\*\* The category that can be achieved depends on the sensor used.

Table 4 Safety characteristic of EX245-FPS#

Item \ Operation	Output with Two Channel Input	Outputs (only)	Two Channel Input (only)	Output with Single Channel Input	Single Channel Input (only)
SFF	99.98%			99.98%	
PFDAV (T) Average Probability of Dangerous Failure	1% of 10 <sup>-3</sup>			1% of 10 <sup>-2</sup>	
PFH (T) Probability of dangerous failure per hour	1% of 10 <sup>-7</sup>			1% of 10 <sup>-6</sup>	
Achievable Safety Level	SIL3 / PL e			SIL2 / PL d	

Comment:

The Outputs and internal Safety Logic always operate in Two-Channel Mode.

The Module achieves with or without Two-Channel-Inputs Safety Level SIL3 / PL e.

In combination with Single-Channel-Inputs the Module can only achieve SIL2 / PL d.

## 4. Diagnostics

The diagnostics of the system are based on detecting that the VP/VG valve is not in the correct state when required or that there is a failure in the diagnostic feedback to the safety PLC. Diagnostics shall be carried out in accordance with the relevant architecture of the system and in consideration of the hazards and risks of the application.

### 4-1. VP/VG Diagnostics

In the safe (exhaust) position the monitoring switch is in the closed position as it has normally closed contacts. The contacts are wired to produce a logic "1" for the input data in equivalent mode only when they both closed confirming that the valve is in the safe state.

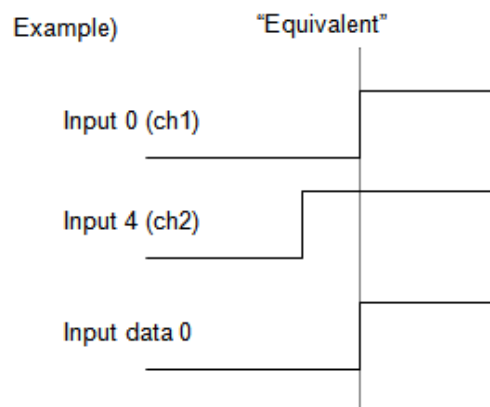

The user should design, test and validate an appropriate function block in the safety PLC to ensure that the valve(s) are operating correctly in accordance with the requirements of the system architecture:

prior to the initiation of any hazardous situation, e.g. start of a new cycle, start of other movements, immediately upon on demand of the safety function and/or periodically during operation if the risk assessment and the kind of operation shows that it is necessary, in accordance with the requirements of ISO 13849 Cat. 2

or,

at or before the next demand upon the safety function in accordance with ISO 13849 Cat. 3

or,

at before the next demand upon the safety functions, e.g. immediately, at switch on, or at end of a machine operating cycle in accordance with ISO 13849 Cat. 4

## 4-2. EX245-FPS# Diagnostics

The safe state for the system is the energy-free / pressure-free state. Safe and error-free state is shown with status 1 in the process image of the inputs. If the valve is on or has not switched off or there is an error, this is shown with status 0.

The safe state for the SI unit is the transmission of the value "0" in the image of the inputs to the safe controller. This happens when there is a detected error in the input which then indicates that the valve status is not safe.

Refer to the condition when input value/output value of SI unit becomes "0" in the manual. (1)

The user should design, test and validate an appropriate function block in the safety PLC to ensure that the plausibility of the logic input signals is monitored and checked on a regular basis. Any discrepancy shall trigger the shutdown of the machine and the de-energisation of the venting valves. User intervention to identify and resolve the source of the discrepancy shall be required before the machine is restarted.

Please refer to the respective manual for information on reported errors and causes.

## 5. Timing Chart

Figure 1 shows the relationship between the valve operation, switch outputs and system pressure.

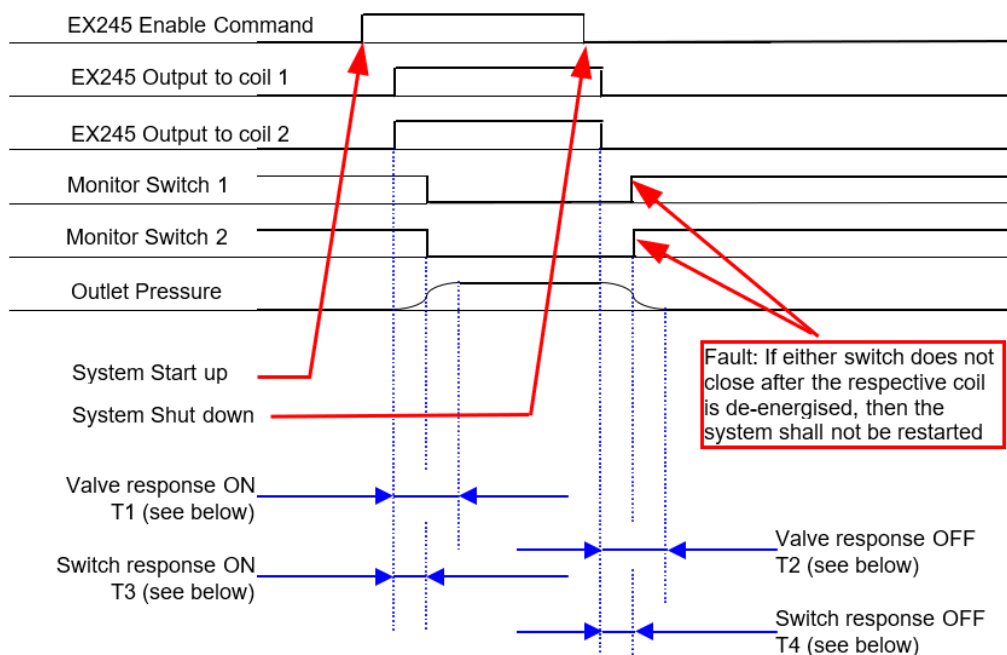

Figure 1

\* The cycle time of PLC and the internal processing time etc. of EX245 are added besides the time that has been described to above-mentioned Figure 1.

\*\* The valve response times T1-T4 are given in the respective product instruction manuals.(2)-(5)

\*\*\* For single valve options there is only one coil and one monitor switch

## 6. Electric wiring examples

### 6-1. Safety outputs (Zone1 to Zone3) with diagnostic (2 safety inputs)

The safety level that can be achieved in the following arrangement is SIL 3, Cat. 4, PL e if wired as shown in Figure 2 and Figure 3.

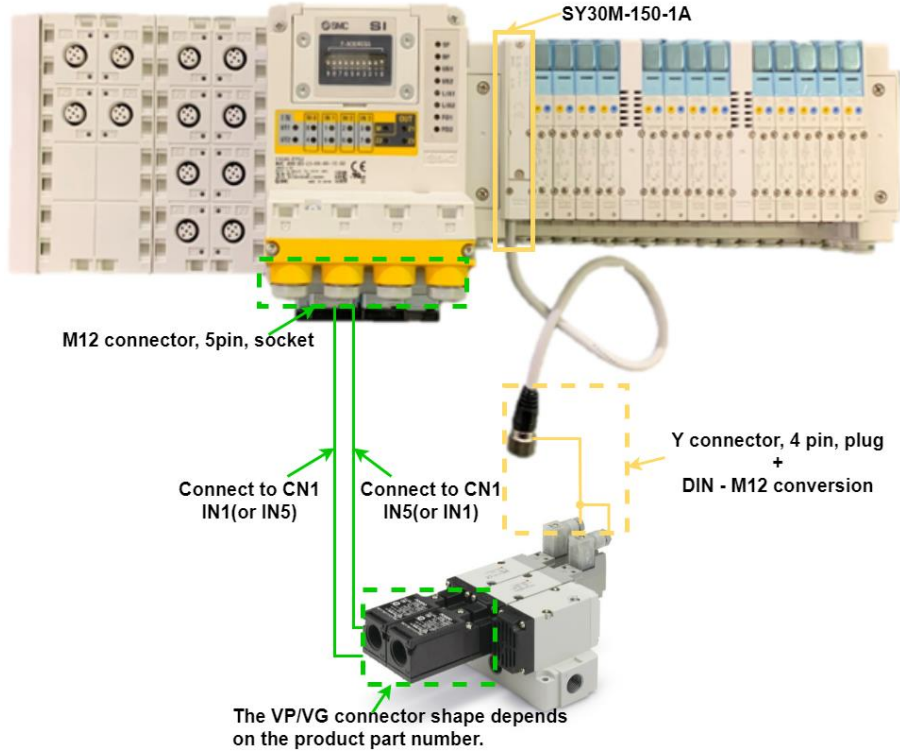

Figure 2

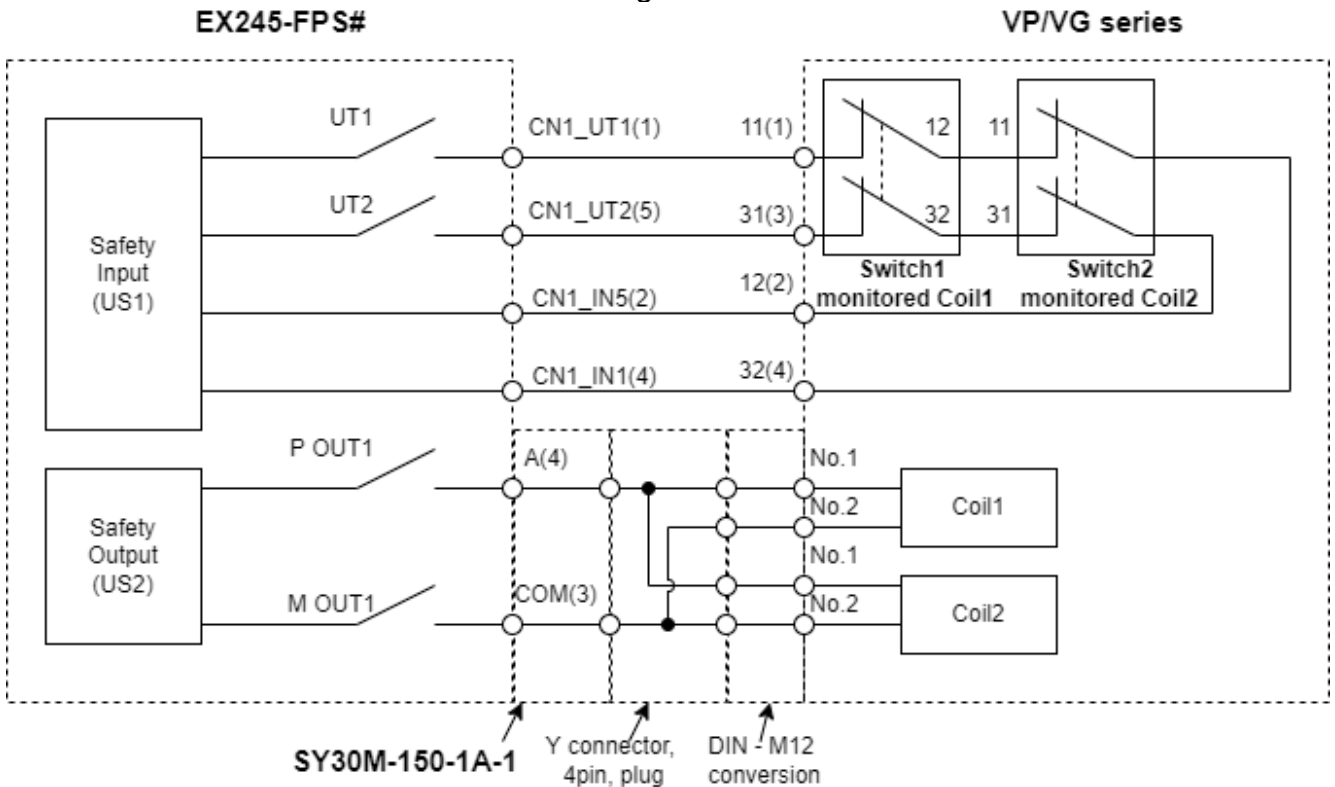

Figure 3



\*Note this uses a two-channel input in an equivalent mode. It is checking the status of both pressure relief valves at the same time. This method reduces the number of safety inputs required. As an option one pair of input can be used for each valve. This does not affect the level of safety but does allow the PLC to determine which of the two valves has not entered the safe state.

\*\*Note that the safety level of the completed system depends on the components and connections that are used for the associated valves in the manifold.

\*\*\* The requirements for fault exclusions in the cables stated in ISO 13849-2 must be met.

\*\*\*\* For details of the zones and the pin assignment of EX245-FPS# connection to the valve manifold, please consult the operation manual.

### **6-2. Safety output (Zone M) with diagnostics (2 safety inputs)**

The safety level that can be achieved in the following arrangement is SIL3, Cat.4, PLe if wired as shown in Figure 4 and Figure 5.

This option may be needed because the positions in the manifold required for the SY30M-150-1A adapter are already used for valves. Or in circumstances where there is a need to switch a number of VP/VG valves on a system at the same time.

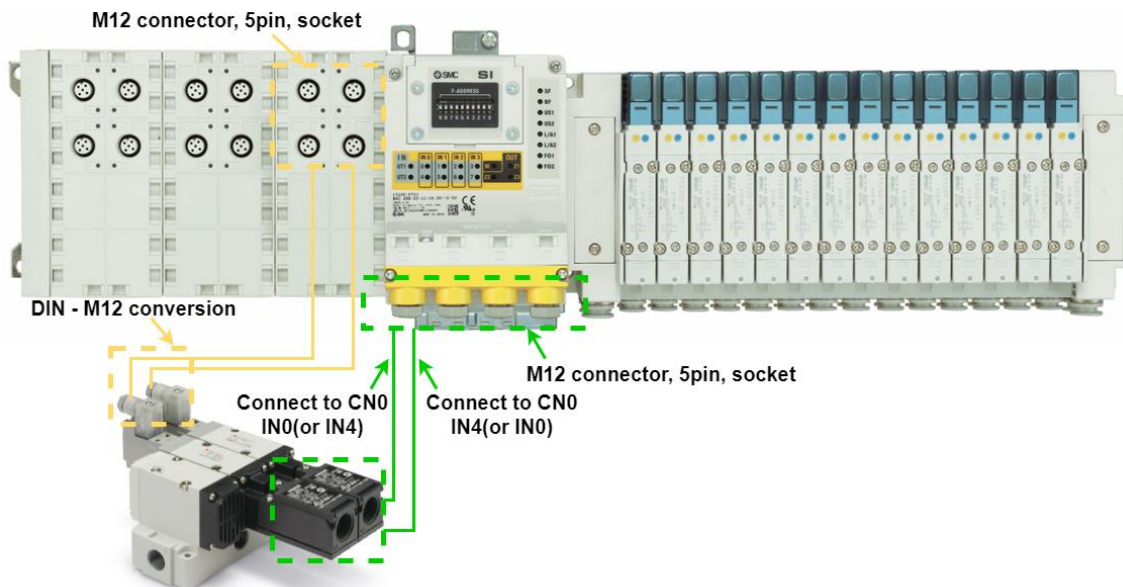

Figure 4

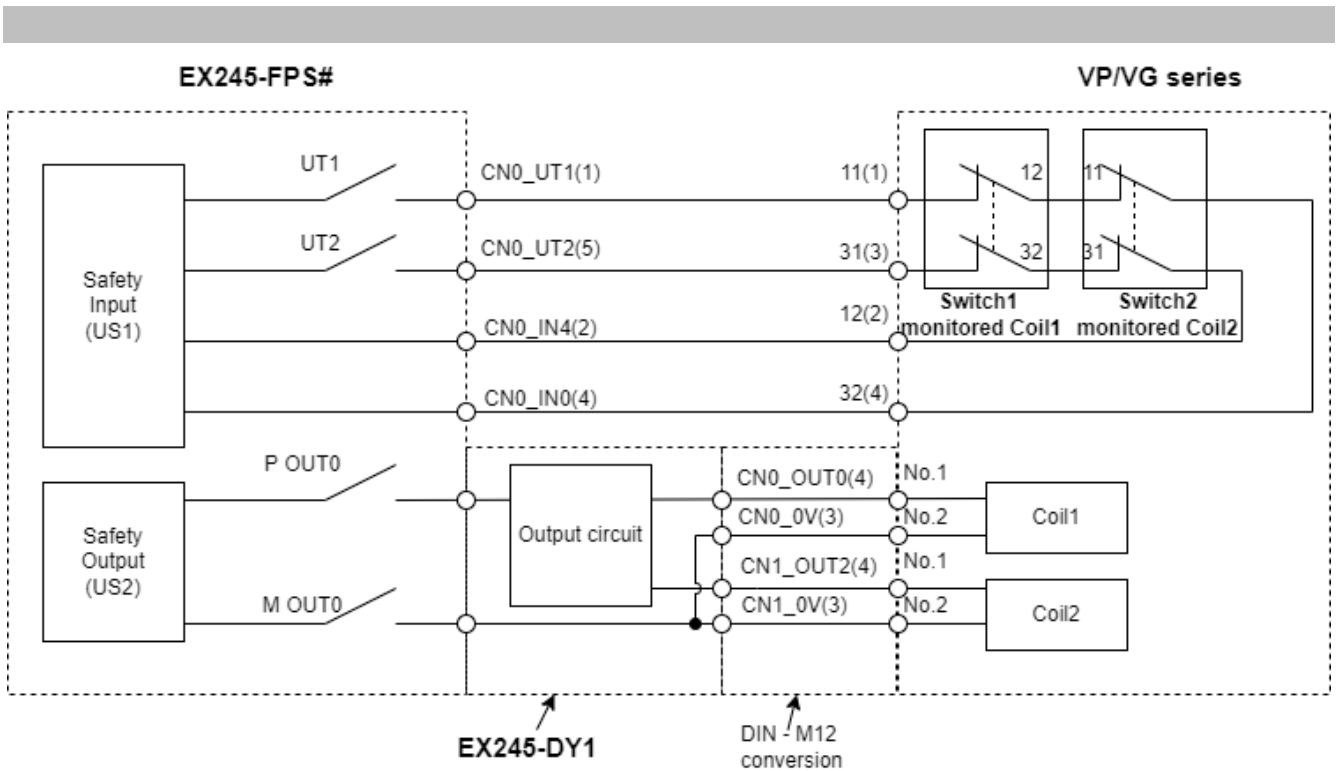

Figure 5

\*Note this uses a two-channel input in an equivalent mode. It is checking the status of both pressure relief valves at the same time. This method reduces the number of safety inputs required. As an option one pair of input can be used for each valve. This does not affect the level of safety but does allow the PLC to determine which of the two valves has not entered the safe state.

\*\*Note that the safety level of the completed system depends on the components and connections that are used for the associated valves in the manifold.

\*\*\* The requirements for fault exclusions in the cables stated in ISO 13849-2 must be met.

\*\*\*\* When a Fault occurs in Zone M, the safety outputs supplying power to all DY modules are shifted to a safe state. Hence all outputs of any EX245-DY1 modules which are connected to EX245-FPS# are also de-energised. (Module passivation).

Note: The DY module has short-circuit detect and current limit, with automatic retry for short to supply and short to ground for each of its outputs, that operate independently of the safety function. In the case that such a fault is detected only the affected output of the DY is turned off.

### 6-3. Safety outputs (Zone1 to Zone3) with diagnostic (1 safety input)

The safety level that can be achieved in the following arrangement is SIL2, Cat. 2 PL c if wired as shown in Figure 6 and Figure 7.

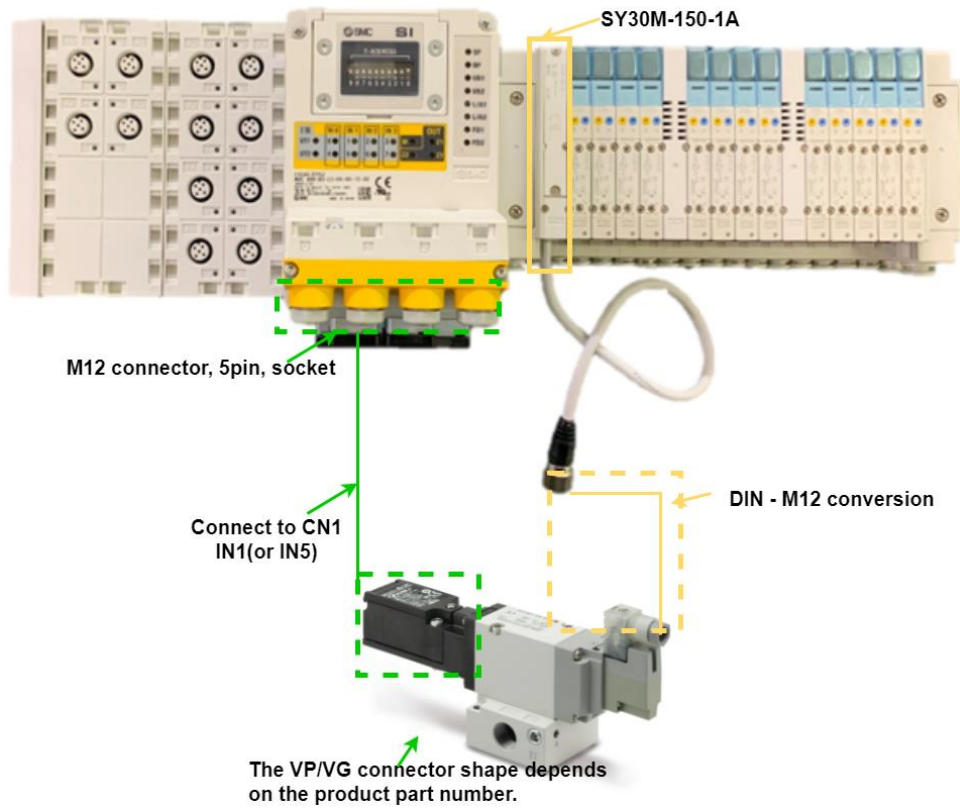

Figure 6

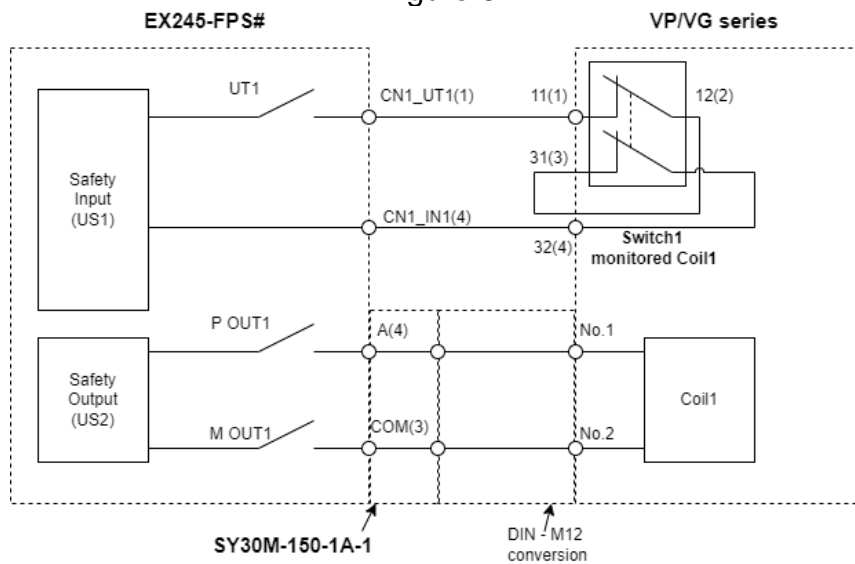

Figure 7

\*Note that the safety level of the completed system depends on the components and connections that are used for the associated valves in the manifold.

\*\* The requirements for fault exclusions in the cables stated in ISO 13849-2 must be met.

### 6-4. Safety outputs (Zone M) with diagnostic (1 Safety input)

The safety level that can be achieved in the following arrangement is SIL2, Cat. 2, PL c if wired as shown in Figure 8 and Figure 9.

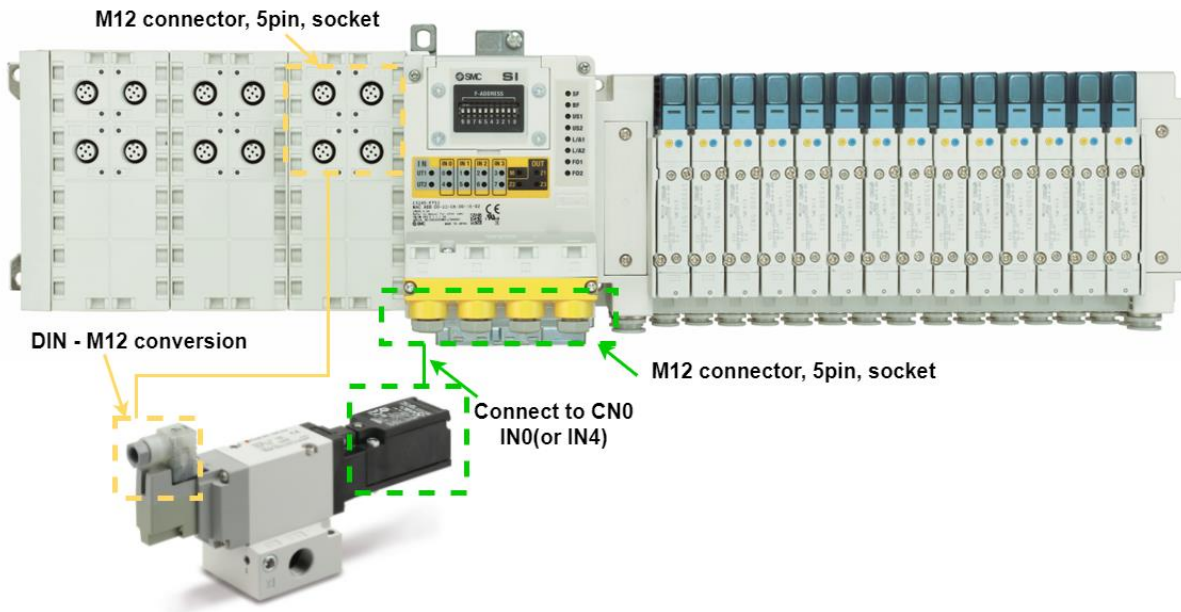

Figure 8

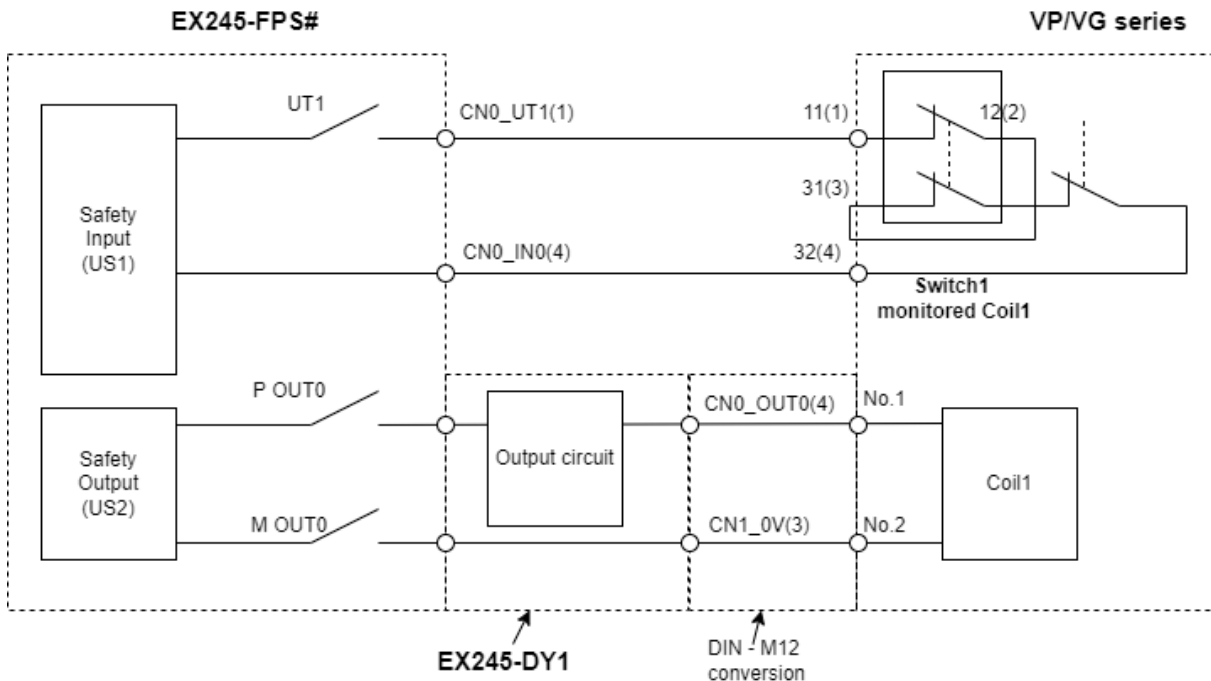

Figure 9

\*Note that the safety level of the completed system depends on the components and connections that are used for the associated valves in the manifold.

\*\* The requirements for fault exclusions in the cables stated in ISO 13849-2 must be met.

## **7. Safety relevant data**

Please refer to the respective user manuals for the safety relevant data, Mission Time, PFH, PFD, HFT, MTTFd, B10d, etc.

Revision history
Issued: 2021.July.26th A: 2023.August.29th

## **SMC Corporation**

4-14-1, Sotokanda, Chiyoda-ku, Tokyo 101-0021 JAPAN

Tel: + 81 3 5207 8249 Fax: +81 3 5298 5362

URL <https://www.smcworld.com>

---

Note: Specifications are subject to change without prior notice and any obligation on the part of the manufacturer.

© 2021-2023 SMC Corporation All Rights Reserved