



# Operation Manual

PRODUCT NAME

***CC-Link Direct Input Type  
Step Motor Controller  
(Servo 24 VDC)***

MODEL/ Series/ Product Number

## JXCM1



**SMC Corporation**

<b>1. Safety Instructions</b> .....	<b>5</b>
<b>2. Outlines of Product</b> .....	<b>7</b>
2.1 Features .....	7
2.2 Product configuration.....	8
2.3 How to Order.....	9
2.4 Option .....	10
(1) Actuator cable .....	10
(2) Actuator cable for actuator with lock (for sensor and lock)....	11
(3) Communication connector.....	11
(4) Communication cable for controller setting .....	12
(5) Power supply plug.....	12
(6) Teaching box.....	13
2.5 Start up procedure .....	14
(1) Checking the contents of the package .....	14
(2) Mounting the controller .....	14
(3) Controller Setting .....	14
(4) PLC set up.....	14
(5) Wiring and Connection .....	14
(6) Power ON alarm (error).....	15
(7) Setting parameters .....	15
(8) Setup of the operation parameters.....	16
(9) Test run.....	16
<b>3. Specifications</b> .....	<b>17</b>
3.1 Specifications.....	17
(1) Basic specifications of the product. ....	17
(2) CC-Link communication .....	18
3.2 Parts Description .....	19
3.3 External Dimensions.....	20
(1) Screw mounting (JXCM17#-#).....	20
(2) DIN rail mounting (JXCM18#-#).....	20
3.4 Mounting .....	21
(1) Mounting.....	21
(2) Grounding .....	21
(3) Mounting location .....	22
(4) Precautions for electric actuator installation.....	23
<b>4. Initial Setting</b> .....	<b>24</b>
4.1 Switch (STATION NO., B RATE) .....	24

4.2 Parameter Setting .....	25
4.3 PLC Setting .....	26
<b>5. External Connections .....</b>	<b>27</b>
5.1 PWR: Power supply connector.....	27
5.2 MOT: Motor connector, ENC: Encoder connector.....	27
5.3 SI: Serial I/O Connector .....	27
(1) Connecting the teaching box.....	27
(2) Connection with a PC .....	28
5.4 CC-Link communication connector .....	28
<b>6. Details of Power Supply Plug .....</b>	<b>29</b>
6.1 Power supply plug specifications.....	29
6.2 Electrical Wiring Specifications .....	29
6.3 Power Supply Plug Wiring .....	30
(1) Wiring of power supply (C24V, M24V, 0V).....	30
(2) Wiring of the stop switch (EMG).....	30
(3) Wiring of the lock release (LK RLS) .....	30
6.4 Wiring of shutdown circuit.....	31
(1) Example circuit 1- Single controller with teaching box .....	31
(2) Stop (relay contact (1)) .....	32
(3) Motor power shutdown (relay contact (2)) .....	33
<b>7. Communication Plug Connector .....</b>	<b>34</b>
7.1 Wiring .....	34
7.2 Electric wire specification.....	35
7.3 Wiring of communication plug connector.....	35
<b>8. LED display .....</b>	<b>36</b>
8.1 LED display.....	36
8.2 LED and Controller Status .....	36
<b>9. Mode .....</b>	<b>37</b>
9.1 Outline .....	37
9.2 Step No. instructions operation function .....	37
9.3 Position / speed monitor .....	38
9.4 Operation by numerical instruction .....	38
9.5 Data editing function .....	39
<b>10. Memory map.....</b>	<b>42</b>
10.1 Remote IO (Rx and Ry).....	42
10.2 Remote register (RWr and RWw).....	48

<b>11. Settings and Data Entry .....</b>	<b>59</b>
11.1 Step Data .....	59
11.2 Basic parameters .....	62
11.3 Return to origin parameter .....	65
11.4 Operation parameters .....	66
<b>12. Operations .....</b>	<b>67</b>
12.1 Return to origin position .....	67
12.2 Positioning Operation .....	67
12.3 Pushing Operation .....	68
(1) Pushing operation is successfully performed. ....	68
(2) Pushing operation fails (empty pushing). ....	68
(3) Movement of the workpiece after the completion of the pushing process .....	68
12.4 Controller input signal response time .....	69
12.5 Methods of interrupting operation .....	69
<b>13. Operation Examples .....</b>	<b>70</b>
13.1 Positioning Operation .....	70
13.2 Pushing Operation .....	71
<b>14. Start up procedure for battery-less absolute encoder</b>	<b>72</b>
14.1 Procedure for start up .....	72
14.2 When supplying power for the first time .....	73
14.3 Supply of power .....	74
14.4 Alarm (group E) is cleared by a cut to the power supply .....	75
<b>15. Operation Instructions.....</b>	<b>76</b>
15.1 Operation procedure for Operation by Step date No.....	76
[1] Power on and Return to Origin position .....	76
[2] Positioning operation .....	77
[3] Pushing Operation .....	77
[4] HOLD.....	78
[5] Reset.....	78
[6] Stop.....	78
15.2 Operation procedure for Operation by numerical instruction .....	80
15.3 Operating procedure for the data edit function.....	81
<b>16. Alarm for Motor Control .....</b>	<b>83</b>
16.1 Output signal of Remote IO for the alarm group .....	83
16.2 Alarms and countermeasures .....	84

<b>17. Alarm Detection for CC-Link Communication .....</b>	<b>91</b>
17.1 Alarm details.....	91
<b>18. Precautions for wiring and cable.....</b>	<b>94</b>
<b>19. Electric Actuators/Common Precautions.....</b>	<b>95</b>
19.1 Design and selection .....	95
19.2 Mounting .....	96
19.3. Handling Precautions .....	97
19.4 Operating environment .....	98
19.5 Maintenance Precautions.....	99
19.6 Precautions for actuator with lock.....	99
<b>20. Controller and Peripheral Devices/Specific Product</b>	
<b>Precautions .....</b>	<b>100</b>
20.1 Design and Selection.....	100
20.2 Handling Precautions .....	100
20.3 Mounting .....	101
20.4 Wiring .....	102
20.5 Power supply.....	102
20.6 Grounding.....	102
20.7 Maintenance .....	103
20.8. Specific Precautions for Battery-Less Absolute Encoder.....	103
<b>21. Troubleshooting.....</b>	<b>105</b>
<b>22. Memory map list .....</b>	<b>111</b>
<b>23. Handling Remote Registers .....</b>	<b>115</b>
23.1 Relationship of bit data, byte data, and word data .....	115
23.2 Relationship of binary (BIN), decimal (OCT), and hexadecimal (HEX) numbers .....	116
23.3 Installation .....	117
<b>24. Definitions and terminology.....</b>	<b>118</b>



# JXCM1 / Controller

## 1. Safety Instructions

These safety instructions are intended to prevent hazardous situations and/or equipment damage. These instructions indicate the level of potential hazard with the labels of "Caution", "Warning" or "Danger".

They are all important notes for safety and must be followed in addition to International Standards (ISO/IEC)\*1), and other safety regulations.

\*1) ISO 4414: Pneumatic fluid power -- General rules relating to systems.

ISO 4413: Hydraulic fluid power -- General rules relating to systems.

IEC 60204-1: Safety of machinery -- Electrical equipment of machines .(Part 1: General requirements)

ISO 10218: Manipulating industrial robots -Safety.

etc.



### Caution

**Caution** indicates a hazard with a low level of risk which, if not avoided, could result in minor or moderate injury.



### Warning

**Warning** indicates a hazard with a medium level of risk which, if not avoided, could result in death or serious injury.



### Danger

**Danger** indicates a hazard with a high level of risk which, if not avoided, will result in death or serious injury.

## Warning

### 1. The compatibility of the product is the responsibility of the person who designs the equipment or decides its specifications.

Since the product specified here is used under various operating conditions, its compatibility with specific equipment must be decided by the person who designs the equipment or decides its specifications based on necessary analysis and test results.

The expected performance and safety assurance of the equipment will be the responsibility of the person who has determined its compatibility with the product.

This person should also continuously review all specifications of the product referring to its latest catalog information, with a view to giving due consideration to any possibility of equipment failure when configuring the equipment.

### 2. Only personnel with appropriate training should operate machinery and equipment.

The product specified here may become unsafe if handled incorrectly.

The assembly, operation and maintenance of machines or equipment including our products must be performed by an operator who is appropriately trained and experienced.

### 3. Do not service or attempt to remove product and machinery/equipment until safety is confirmed.

1. The inspection and maintenance of machinery/equipment should only be performed after measures to prevent falling or runaway of the driven objects have been confirmed.

2. When the product is to be removed, confirm that the safety measures as mentioned above are implemented and the power from any appropriate source is cut, and read and understand the specific product precautions of all relevant products carefully.

3. Before machinery/equipment is restarted, take measures to prevent unexpected operation and malfunction.

### 4. Contact SMC beforehand and take special consideration of safety measures if the product is to be used in any of the following conditions.

1. Conditions and environments outside of the given specifications, or use outdoors or in a place exposed to direct sunlight.

2. Installation on equipment in conjunction with atomic energy, railways, air navigation, space, shipping, vehicles, military, medical treatment, combustion and recreation, or equipment in contact with food and beverages, emergency stop circuits, clutch and brake circuits in press applications, safety equipment or other applications unsuitable for the standard specifications described in the product catalog.

3. An application which could have negative effects on people, property, or animals requiring special safety analysis.

4. Use in an interlock circuit, which requires the provision of double interlock for possible failure by using a mechanical protective function, and periodical checks to confirm proper operation.



# JXCM1 / Controller

## 1. Safety Instructions

### Caution

**1. The product is provided for use in manufacturing industries.**

The product herein described is basically provided for peaceful use in manufacturing industries. If considering using the product in other industries, consult SMC beforehand and exchange specifications or a contract if necessary. If anything is unclear, contact your nearest sales branch.

## Limited warranty and Disclaimer/Compliance Requirements

The product used is subject to the following "Limited warranty and Disclaimer" and "Compliance Requirements".

Read and accept them before using the product.

### Limited warranty and Disclaimer

1. The warranty period of the product is 1 year in service or 1.5 years after the product is delivered, whichever is first.\*2)  
Also, the product may have specified durability, running distance or replacement parts. Please consult your nearest sales branch.
2. For any failure or damage reported within the warranty period which is clearly our responsibility, a replacement product or necessary parts will be provided.  
This limited warranty applies only to our product independently, and not to any other damage incurred due to the failure of the product.
3. Prior to using SMC products, please read and understand the warranty terms and disclaimers noted in the specified catalog for the particular products.  
\*2) Vacuum pads are excluded from this 1 year warranty.  
A vacuum pad is a consumable part, so it is warranted for a year after it is delivered. Also, even within the warranty period, the wear of a product due to the use of the vacuum pad or failure due to the deterioration of rubber material are not covered by the limited warranty.

### Compliance Requirements

1. The use of SMC products with production equipment for the manufacture of weapons of mass destruction (WMD) or any other weapon is strictly prohibited.
2. The exports of SMC products or technology from one country to another are governed by the relevant security laws and regulation of the countries involved in the transaction. Prior to the shipment of a SMC product to another country, assure that all local rules governing that export are known and followed.

### Caution

**SMC products are not intended for use as instruments for legal metrology.**

Products that SMC manufactures or sells are not measurement instruments that are qualified by pattern approval tests relating to the measurement laws of each country.

Therefore, SMC products cannot be used for business or certification ordained by the measurement laws of each country.

## 2. Outlines of Product

### 2.1 Features

Features of the controller.

- CC-Link compatible

CC-Link operation is available by connecting with CC-Link. Information can be written and read to and from it.

- Actuator control

Positioning operation and operation at a specific speed and force for the actuator are possible by controlling the Step motor (servo 24VDC).

- Specified force operation

Control the pushing force or the pressing force of the actuator.

- Separated power supply

Power supply input is separated into the motor power supply and control power supply. Even if the power supply for the motor is turned OFF, the information from the encoder position is not lost while the control power supply is ON, and CC-Link communication and serial communication is available.

- Return to origin

Returning to origin is possible by a signal from CC-Link.

- Alarm detection function

Abnormal conditions are automatically detected. Alarms are output via CC-Link communication. The alarm history can be stored in the controller memory.

- Positioning / pushing operation is available with step data and numerical operation mode

It is possible to operate the actuator by using the saved step data and by numeric data operation instruction by using CC-Link communication.

In the step data operation mode, the operation is instructed by manipulating the memory which is relevant to input/output port such as DRIVE signal and INP signal. The actuator operates in accordance with the step data operating pattern of the specified step data.

In the numerical operation mode, the operation is executed by specifying the relevant numeric data.

- "AREA" signal

The controller has an "AREA" signal that turns ON if the actuator position is within the range specified by "Area 1" and "Area 2" in the step data.

- Data input method

It is possible to perform parameter setup, status monitoring, trial run and alarm reset via CC-Link communication or the serial communication with a PC installed with the controller setting software or the teaching box.

- Easy mode and Normal mode

There are two available modes for the controller setting software and the teaching box. In Easy mode, you can start the operation by only setting the speed, position, etc. In Normal mode, further detailed setup can be performed.

- Applicable for the Battery-Less Absolute Encoder

Detection of the absolute position enables the encoder to detect the actuator position when power is supplied, so operation is available with no return to origin operation.

### **Caution**

When the device is set up or failure occurs, please refer the operation manual of the actuator, the teaching box, and controller setting software as well as this operation manual.

Keep this operation manual accessible for reference when necessary.



## 2.2 Product configuration

An example of the controller structure is shown below.

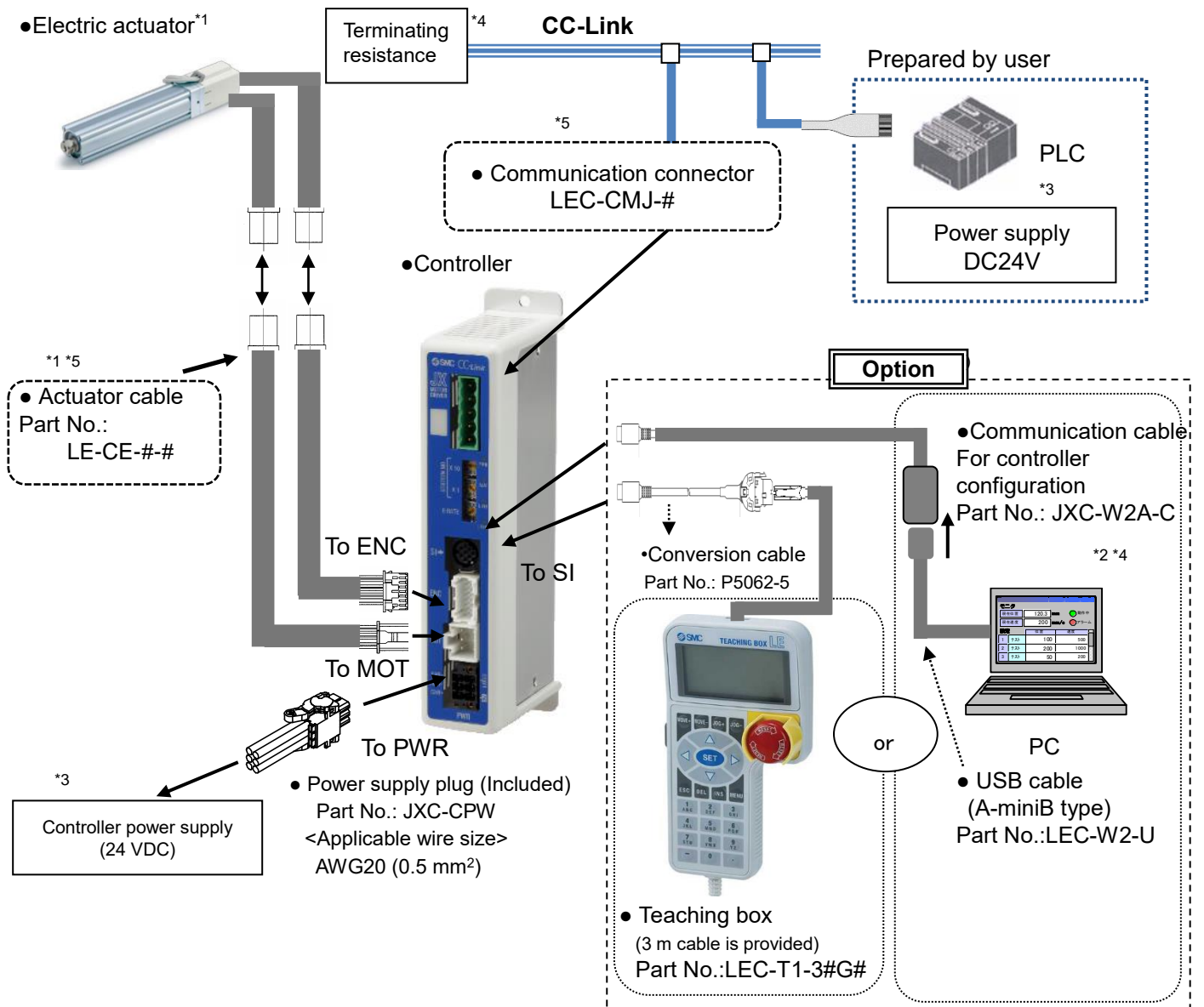

\*1 These items are included when ordered using the part number for an Electric actuator set.

\*2 Please download the controller configuration software from the SMC website.  
<https://www.smcworld.com/>

\*3 24 VDC power supply for controller input and 24 VDC power supply for I/O signal should be separated

\*4 Be sure to prepare a terminating resistor and a PC.

\*5 Optional.

### ⚠ Warning

Refer to **5. External Connections** for wiring.

Refer to “**18. Precautions for wiring and cables**” when handling the wiring and cables.

Do not connect the teaching box, LAN equipment, or LAN cable directly to a PC.

Otherwise, the controller, PC or equipment may be damaged.

## 2.3 How to Order

How to order is shown below.

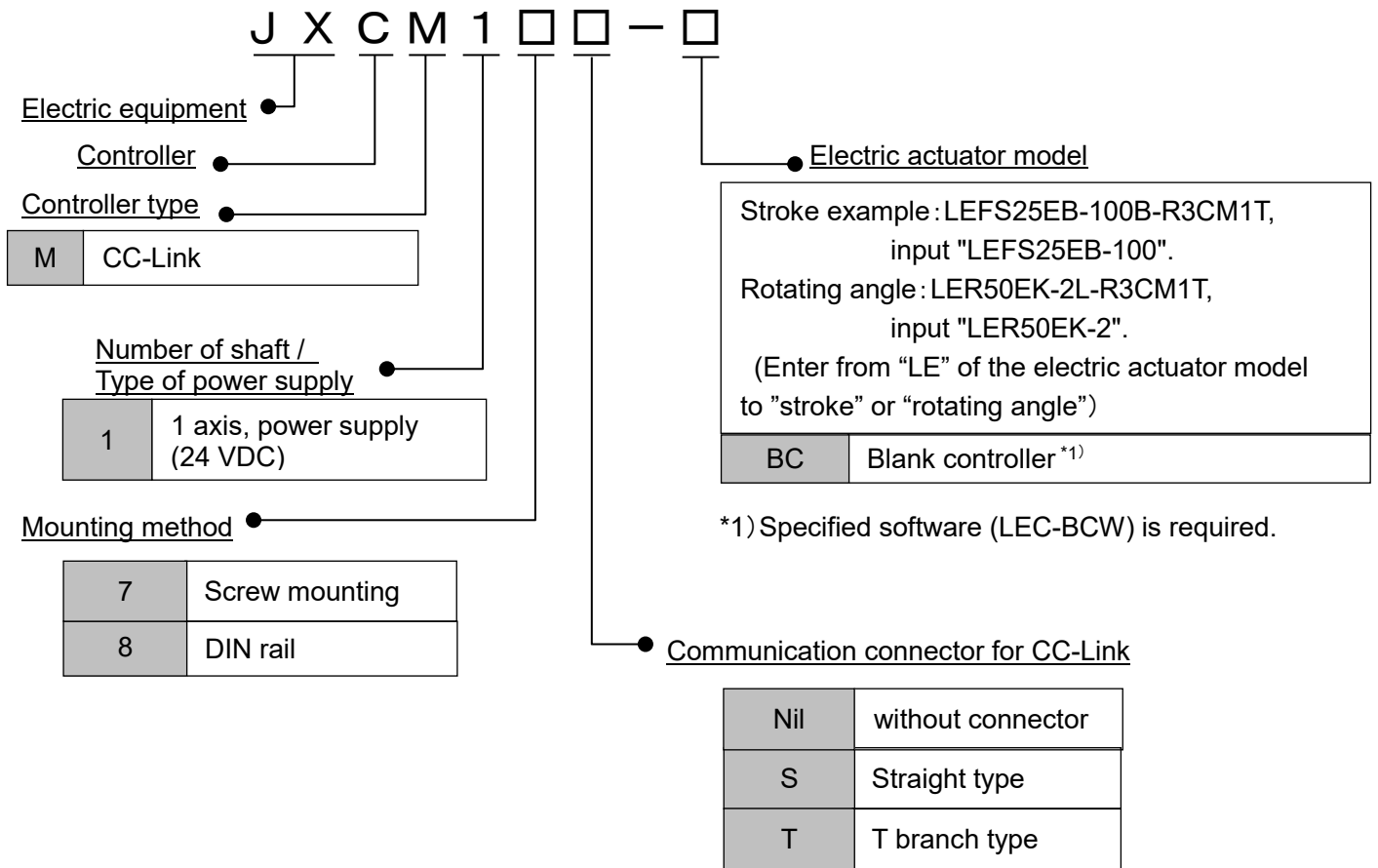

### ⚠ Caution

Single controllers are also shipped after setting the electric actuator specification parameters.

Confirm the combination of the controller and the electric actuator is correct.

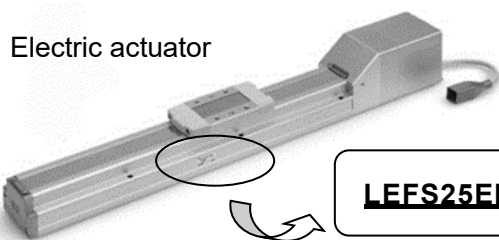

Controller



## 2.4 Option

### (1) Actuator cable

LE-CE-#  
Cable length (L)

1	1.5m
3	3m
5	5m
8	8m*
A	10m*
B	15m*
C	20m*

\* Produced upon receipt of order

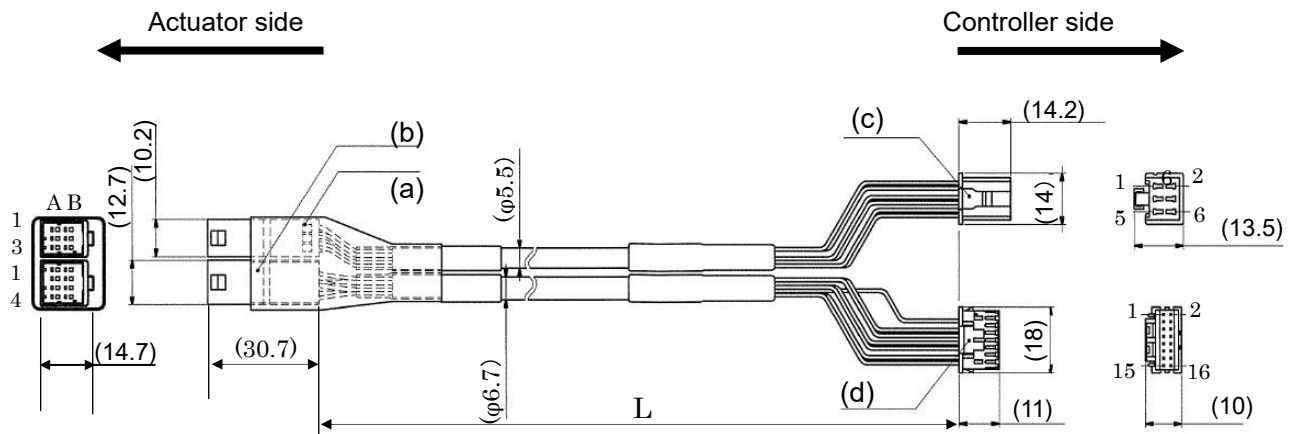
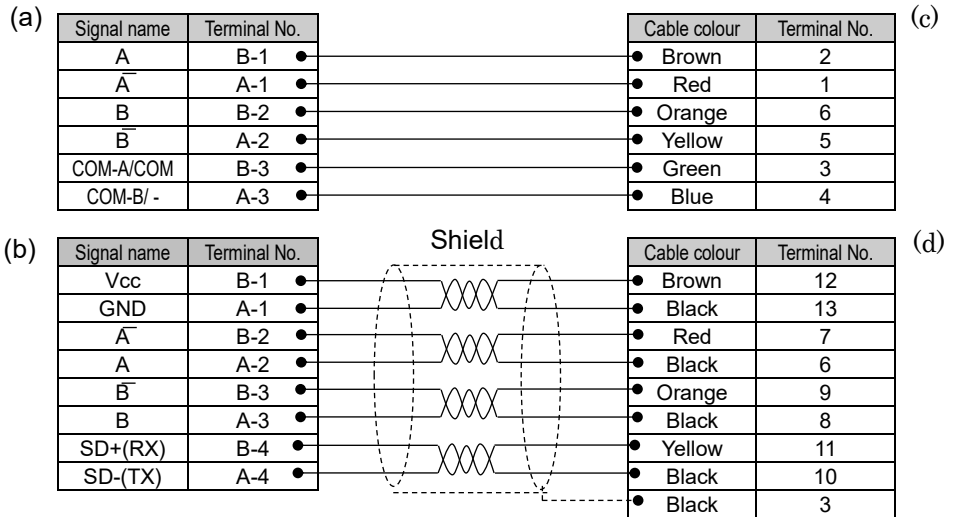

## (2) Actuator cable for actuator with lock (for sensor and lock)

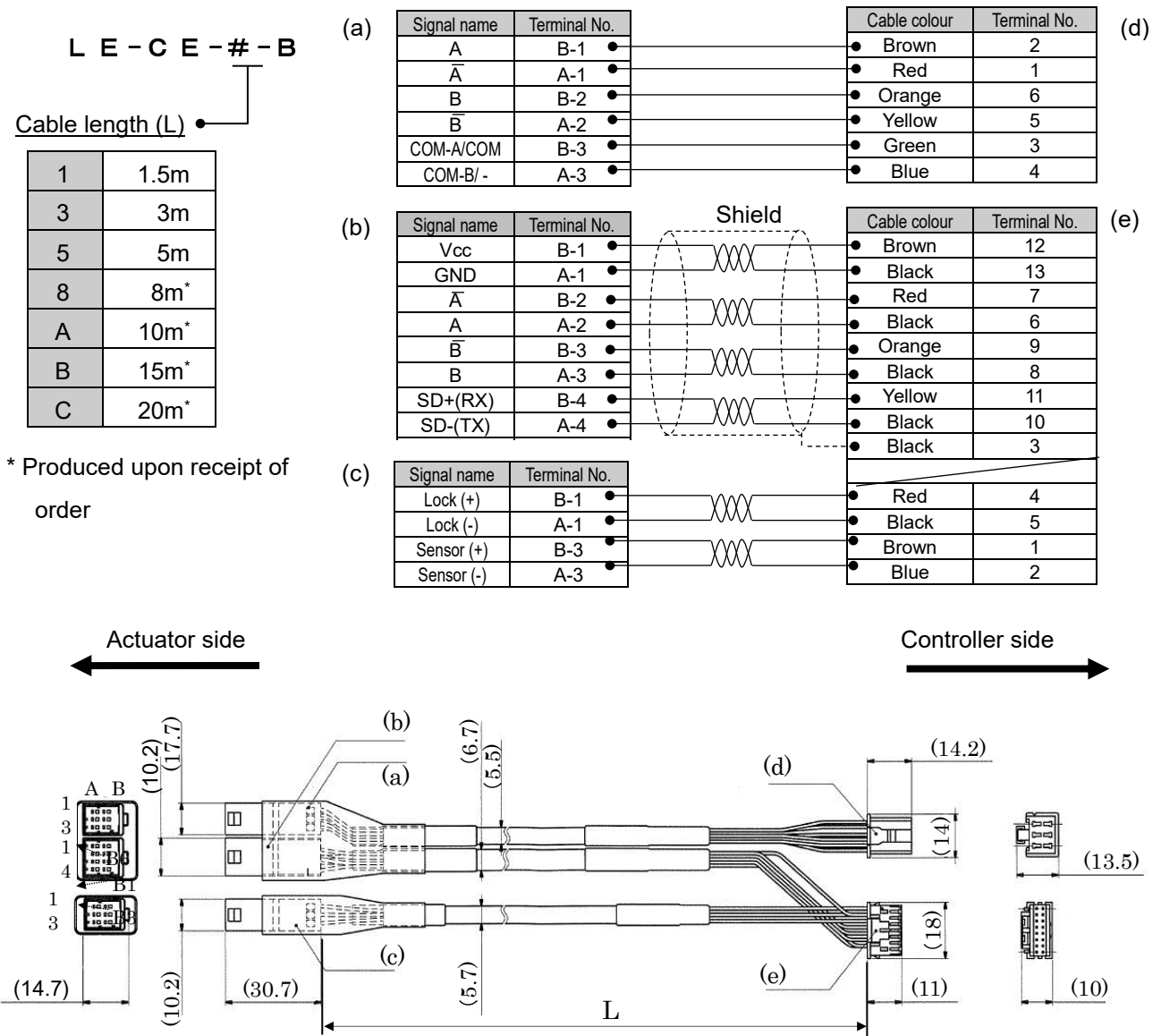

## (3) Communication connector

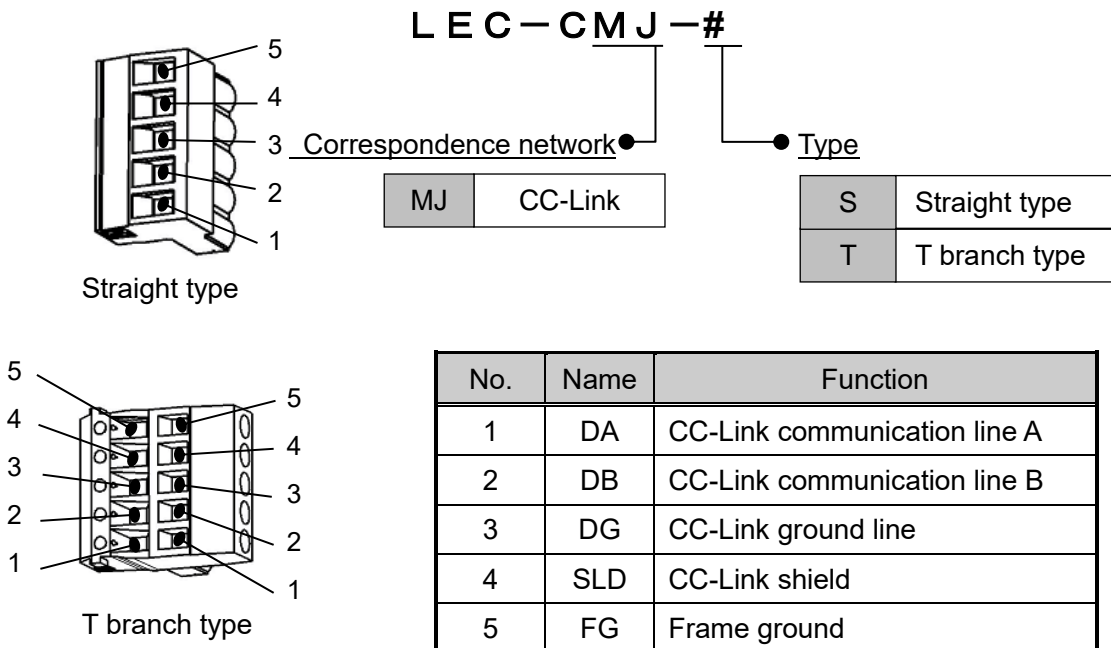

#### (4) Communication cable for controller setting

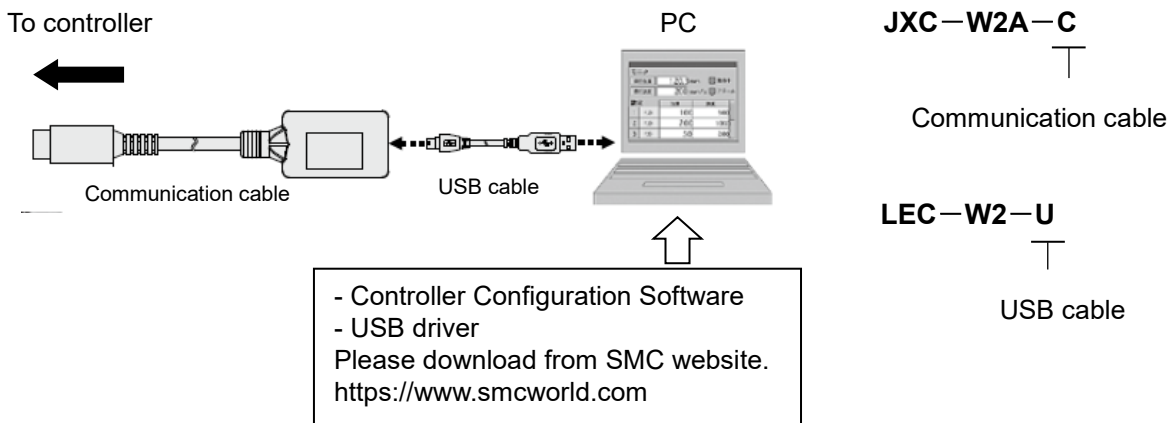

#### Operating environment

OS	Window®7, Windows®8.1, Windows®10
Communication interface	USB1.1 or USB2.0 port
Display	1024×768 or more

Windows®7, Windows®8.1, and Windows®10 are registered trademarks of United States Microsoft Corporation.

### ⚠ Caution

The latest version of the controller setting software must be used.  
Please download from SMC website. <http://www.smcworld.com/>

#### (5) Power supply plug

##### JXC-CPW

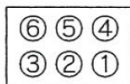
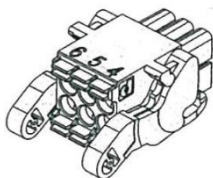

- ① C24V    ④ 0V
- ② M24V    ⑤ N.C.
- ③ EMG    ⑥ LK RLS

##### Power Supply Plug

No.	Terminal	Function	Details
1	C24V	Control power supply (+)	Positive control power to be supplied to the controller.
2	M24V	Motor power (+)	Positive control power to be supplied to the motor.
3	EMG	Stop (+)	The positive power for Stop signal.
4	0V	Common power (-)	The negative common power for M24V, C24V, EMG and LK RLS.
5	-	NC	N/A
6	LK RLS	Unlocking (+)	Positive power for unlocking.

## (6) Teaching box

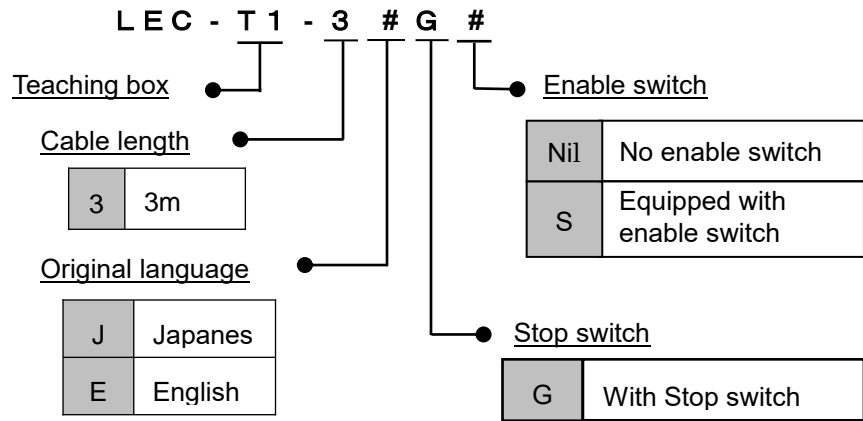

### Conversion cable for connecting the teaching box

**P5062-5** (Cable length: 0.3 m)

\* Required for connecting the teaching box and JXC controller

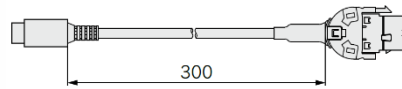

## Dimensions

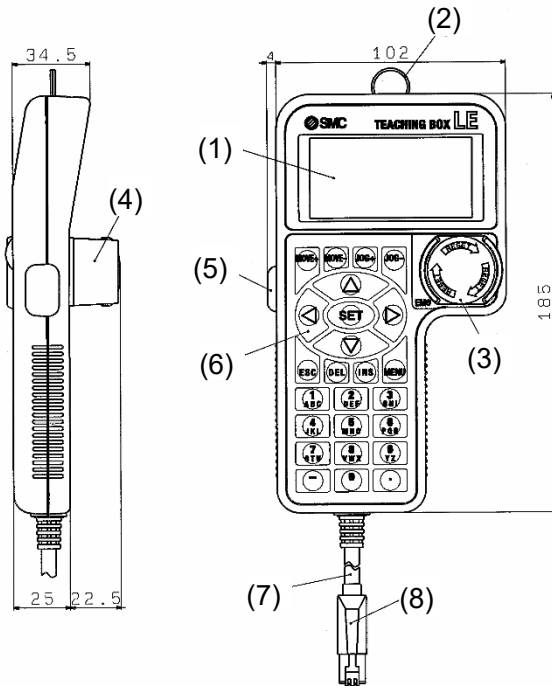

No	Indication	Function
(1)	LCD	Liquid crystal display (with backlight)
(2)	Ring	The ring to hang the teaching box.
(3)	Stop switch	When the switch is pressed, the switch locks and it stops. Turn clockwise to release the lock.
(4)	Stop guard	Protector for the stop switch
(5)	Enable switch (Option)	Switch to prevent unintentional operation of Jog test function. * Does not apply to other functions e.g. data change
(6)	Key switch	Entry switches
(7)	Cable	3m length
(8)	Connector	The connector to be connected to the CN4 of the controller

## 2.5 Start up procedure

Be sure to check the procedure below before use.

### (1) Checking the contents of the package

After unpacking everything, check the description on the label to identify the controller and the number of accessories. If any parts are missing or damaged, please contact your distributor.

Product name	Quantity
Controller (JXCM1##-#)	1 pc.
Power supply plug (JXC-CPW)	1 pc.
Communication plug (LEC-CMJ-#)*1)	1 pc.

\*1) These items are included when ordered using the part number for an actuator set.

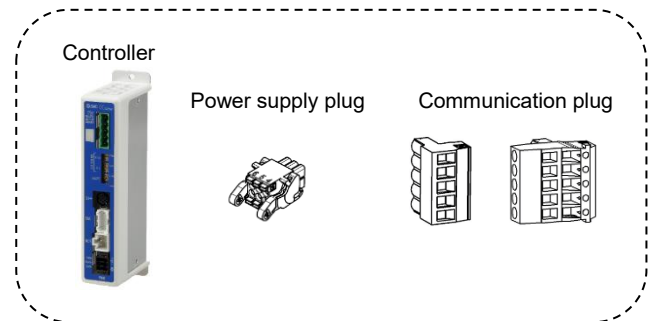

#### [Options]

- Teaching box
- Communication cable for controller configuration
- Actuator cable
- Communication plug

Teaching box



Communication cable for controller configuration



Actuator cable

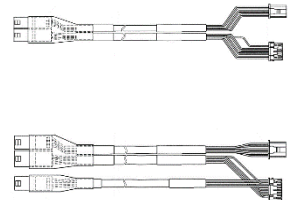

### (2) Mounting the controller

Refer to section [3.4 Mounting](#) for instructions on how to mount the controller.

### (3) Controller Setting

It is necessary to set the address and the communication speed by the rotary switch of controller.

Please refer to the “[4.1 Switch \(STATION NO., B RATE\)](#)”

### (4) PLC set up

Set the PLC parameter as a master station. Please refer to the “[4.3 PLC setting](#)”.

### (5) Wiring and Connection

Prepare the electric actuator and the cable.

Connect the cables to the controller.

Refer to [5. External Connections](#) for the wiring of the connectors.

## (6) Power ON alarm (error)

Ensure the stop is not activated and then supply 24 VDC power.

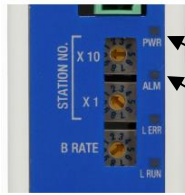

Controller

LED	LED condition	Status
PWR	Green LED is ON	Normal
ALM	OFF	No alarm

Refer to the **8. LED display** for the explanation of LED lamps.

If the LED [PWR] lights in green, the controller is in the normal condition.

If the red [ALM] LED on the front of the controller is ON, an alarm has been triggered.

### ⚠ Caution

#### When an alarm is generated

Refer to a corresponding memory of CC-Link or connect a PC or teaching box to the SI serial I/O connector and check the details of the alarm. Then, remove the cause of the error referring to the **16. Alarm for Motor Control**.

\*Please refer to the manuals of the controller setting software or the teaching box for details of the alarms.

## (7) Setting parameters

It is necessary to set the controller parameters. Please refer to the “**4.2 Parameter Setting**”

The status of the LEDs on the front of the controller matches the table below when the setting of PLC and parameters complete properly and CC-Link communication is established.

Items	LED condition	Status
PWR	Green LED is ON	Supply power
ALM	OFF	No alarm
L ERR	OFF	Operating normally
L RUN	Green LED is ON	CC-Link communicating

Refer to **8. LED display** for the explanation of LED lamps.

Communication between PLC and controller is not established when LED[L RUN] on the front of the controller is OFF, or LED[L ERR] red LED flashes or turns ON.

### ⚠ Caution

Communication between PLC and controller is not established.

Refer to “**17. Alarm Detection in CC-Link Communication**”.

Check if the communication speed of the PLC and controller and the information of the host computer are correctly set.

Refwr to “**4.2 Parameter Setting**” and “**4.3 PLC Setting**”.





## 3. Specifications

### 3.1 Specifications

#### (1) Basic specifications of the product.

Item		Specifications			
Compatible motor		Step motor (servo 24 VDC)			
Power supply *1) *2)		Power supply voltage: 24 VDC +/-10% Max. current consumption: 3A (Peak 5A) *3) (for both of motor drive power control power, stop, lock brake release)			
Compatible encoder		Battery-less absolute encoder (resolution: 4096 pulses/rotation)			
Serial communication		RS485			
Memory		EEPROM			
LED display	LED name	PWR	ALM	L ERR	L RUN
	Details	Power supply	Alarm status	CC-Link Error status	CC-Link Communication status
Locking		Unlocking terminal (applicable to non-excitation magnetizing lock)			
Cable length		Actuator cable: 20 m or less			
Cooling method		Air-cooling type			
Operating temperature range		0°C to 55°C (No freezing) *4)			
Operating humidity range		90% RH or less (No condensation)			
Storage temperature range		-10°C to 60°C (No freezing)			
Operating humidity range		90% RH or less (No condensation)			
Insulation resistance		Between the external terminals and case 50 MΩ (500VDC)			
Weight		170 g (Direct mounting type) 190 g (DIN rail mounting type)			

\*1) The controller power supply do not use the power supply of "inrush current restraining type".

\*2) When conformity to UL is required, the electric actuator and controller should be used with a UL1310 Class 2 power supply.

\*3) The power consumption changes depending on the electric actuator model.  
Please refer to the specifications of the electric actuator for more details.

\*4) For the LEY40 and LEYG40 series, if the vertical transfer load is greater than the weight listed below, the controller must be used at an ambient temperature of 40°C or less.  
LEY40□EA: 9 kg, LEY40□EB: 19 kg, LEY40□EC: 38 kg  
LEYG40□EA: 7 kg, LEYG40□EB: 17 kg, LEYG40□EC: 36 kg

**(2) CC-Link communication**

Item		Specifications				
Field bus		CC-Link Version 1.10				
Station type		Remote device station				
Occupied number of stations	Number of stations	1 stations	2 stations	4 stations		
	Number of input points/ number of output points	32 points / 32 points 4 words / 4 words	64 points / 64 points 8 words / 8 words	128 points / 128 points 16 words / 16 words		
Communication speed		156k / 625k / 2.5M / 5M / 10Mbps				
Communication method		Broadcast Polling System				
Synchronization system		Frame synchronous communication				
Encoding method		NRZI				
Transmission system		Bus system (EIA RS485 compliant)				
Communication format		HDLC compliant				
Error control system		CRC ( $X^{16}+X^{12}+X^5+1$ )				
Setup file		CSP+ file (download from SMC website).				
Applicable communication cable		CC-Link Ver.1.10-compatible cable (Three-core twisted-pair cable with shield)				
Cable length	Communication speed (bps)	156k	625k	2.5M	5M	10M
	Total cable length (m)	1200	900	400	160	100

For a system with a CC-Link Ver.1.00-compatible cable coexisting, the maximum length and station-to-station length of the communication cable should follow the specifications for Ver.1.00.

### 3.2 Parts Description

Details of the parts of the controller.

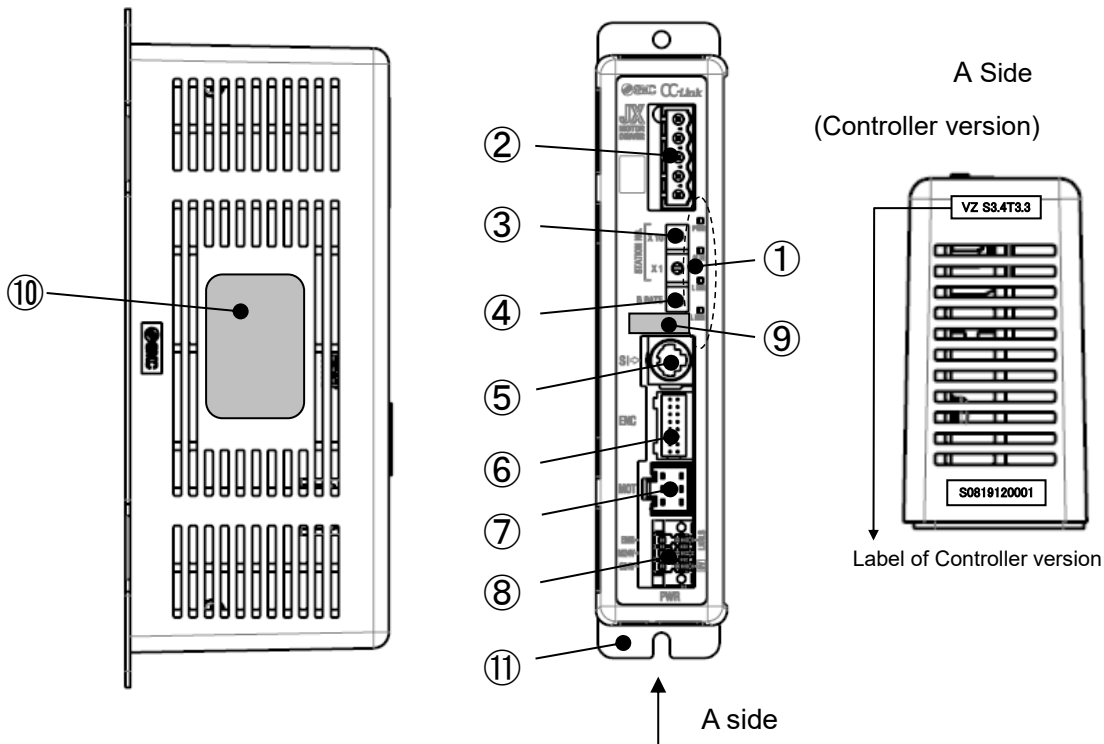

No.	Display	Name	Details
①	-	LED	LED's to indicate the controller status. Refer to <b>8. LED display</b>
②	-	communication connector	Connect to the CC-Link communication line.
③	STATION NO.	STATION NO. switch	Switch for setting address (01 to 64) X1 and X10
④	B RATE	Switch for communication speed setting	Switch to set the CC-Link communication speed.
⑤	SI	Serial I/O connector (8 poles)	Connector for the teaching box (LEC-T1) or the setting software (JXC-W2).
⑥	ENC	Encoder connector (16 poles)	Connect to the actuator cable.
⑦	MOT	Motor driving connector (6 poles)	
⑧	PWR	Power supply connector (6 poles)	Connect to the controller power supply (24VDC) using the power supply plug. Control power (+), Stop signal (+), Motor power (+), Lock release (+), Common power (-)
⑨	-	Applicable electric actuator model number label	Label indicating the electric actuator part number which can be connected to the controller.
⑩	-	Controller part number label	Label indicating the controller part number.
⑪	-	FG	Functional ground (When the controller is mounted, tighten screws and connect the grounding cable.)

### 3.3 External Dimensions

The appearance of this product is as shown in the diagram below:

#### (1) Screw mounting (JXCM17#-#)

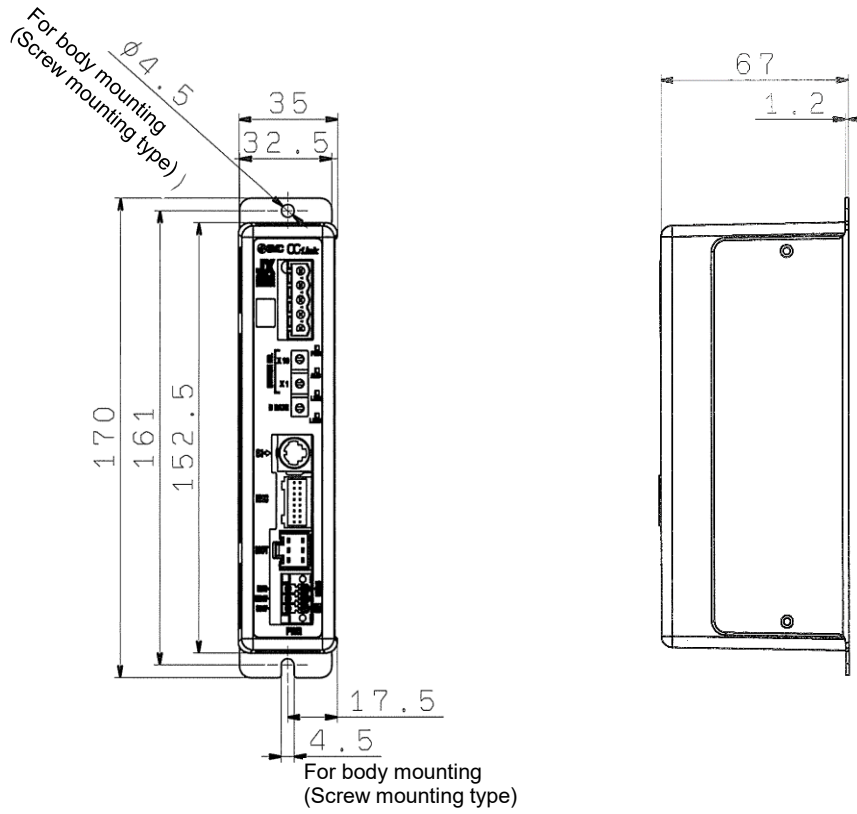

#### (2) DIN rail mounting (JXCM18#-#)

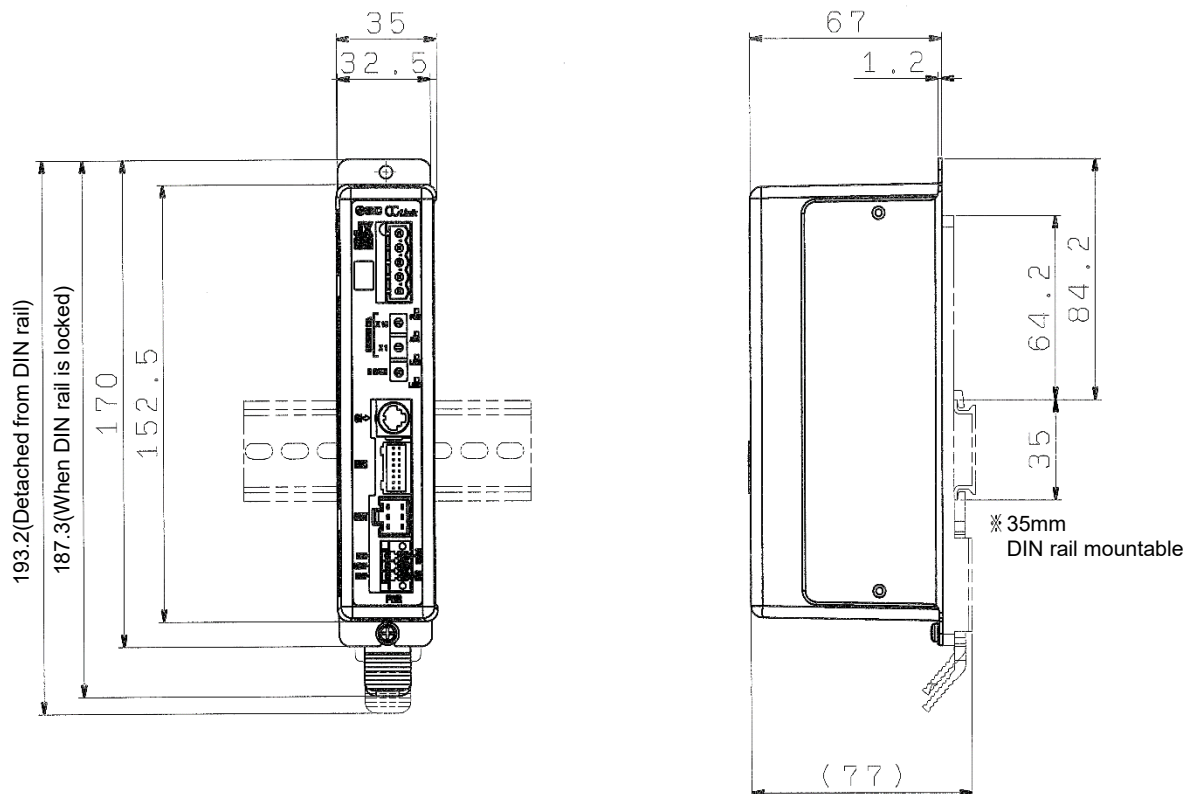

## 3.4 Mounting

### (1) Mounting

The controller can be direct mounted using screws or mounted on a DIN rail.

Details of the controller mounting options are shown below.

#### ① Screw mounting (JXCM17#-#)

(Mounting with two M4 screws)

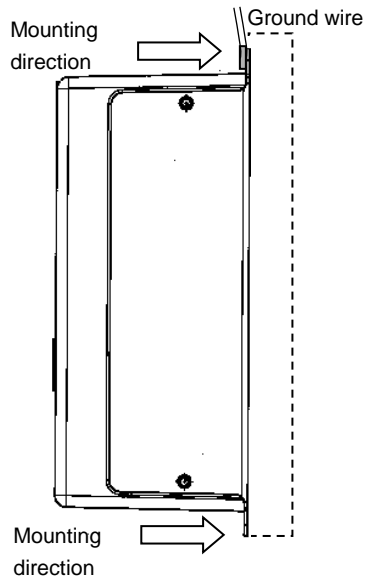

#### ② DIN rail mounting (JXCM18#-#)

(Mounting with DIN rail)

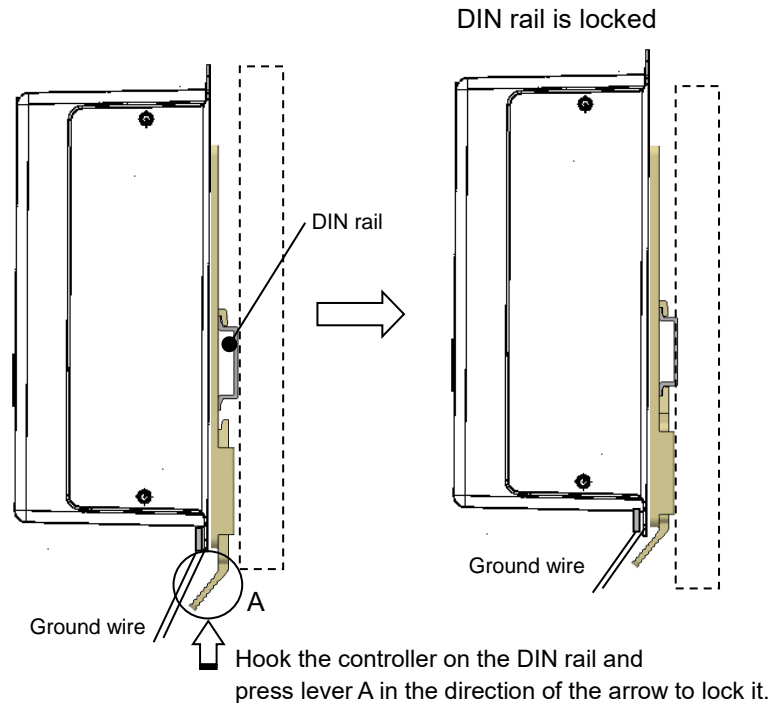

### (2) Grounding

Place the grounding cable with crimped terminal between the M4 screw and shakeproof washer as shown below and tighten the screw.

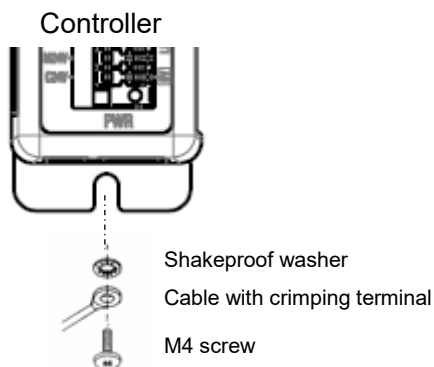

### Caution

The M4 screw, cable with crimped terminal and shakeproof washer must be prepared by the user. The controller must be connected to Ground to reduce noise.

If higher noise resistance is required, ground the 0V (signal ground).

When grounding the 0V, avoid flowing noise from the ground to the 0V

## ⚠ Caution

- ① A dedicated Ground connection must be used. Grounding should be to a D-class ground (ground resistance of 100Ω or less).
- ② The cross sectional area of the grounding cable shall be 2mm<sup>2</sup> minimum. The Grounding point should be as near as possible to the controller. Keep the grounding cable as short as possible.

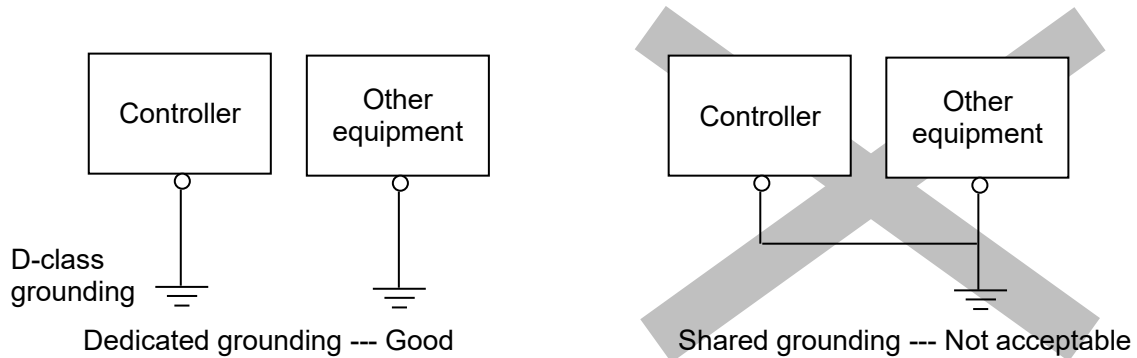

### (3) Mounting location

Design the size of the control panel and the installation so that the temperature surrounding the controller is 55°C or less (Note 1). Mount the controller vertically on the wall with 30 mm minimum space on the top and bottom of the controller as shown below.

Allow 60 mm minimum space between the front of the controller and the door (lid) so that the connectors can be connected and disconnected.

Leave enough space between the controllers so that the operating temperatures of the controllers remain within the specification range.

Avoid mounting the controller near a vibration source, such as a large electromagnetic contactor or circuit breaker on the same panel.

Note) For the LEY40 and LEYG40 series, if the vertical transfer load is greater than the weight listed below, the controller must be used at an ambient temperature of 40°C or less.

LEY40□EA: 9 kg, LEY40□EB: 19 kg, LEY40□EC: 38 kg

LEYG40□EA: 7 kg, LEYG40□EB: 17 kg, LEYG40□EC: 36 kg

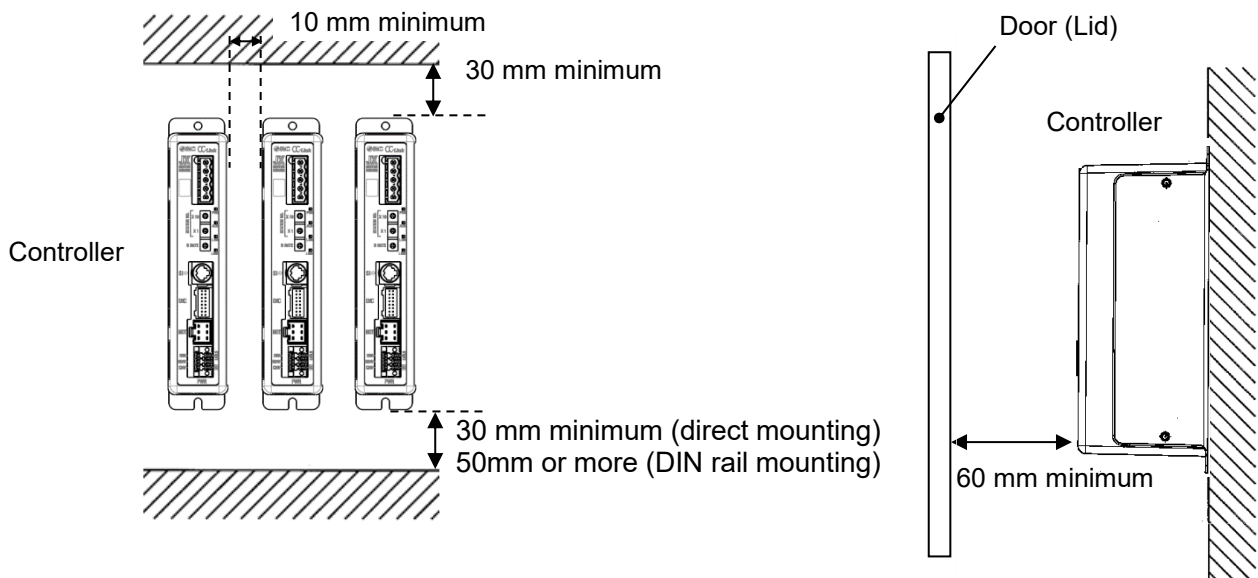

## ⚠ Caution

If the mounting surface for the controller is not flat or is uneven, excessive stress may be applied to the enclosure, which can cause failure. Be sure to mount on a flat surface.

#### (4) Precautions for electric actuator installation

### Warning

**Do not use in an environment where strong magnetic field are present.**

A magnetic sensor is used in the encoder. Therefore, if the actuator motor is used in a strong magnetic field environment, malfunction or failure may occur.

Do not expose the actuator motor to a magnetic field with a magnetic flux density of 1 mT or more.

When installing an electric actuator or an air cylinder with an auto switch (ex. CDQ2 series) or electric actuators side by side, maintain 40 mm minimum space around the motor.

Refer to the construction drawing of the actuator motor.

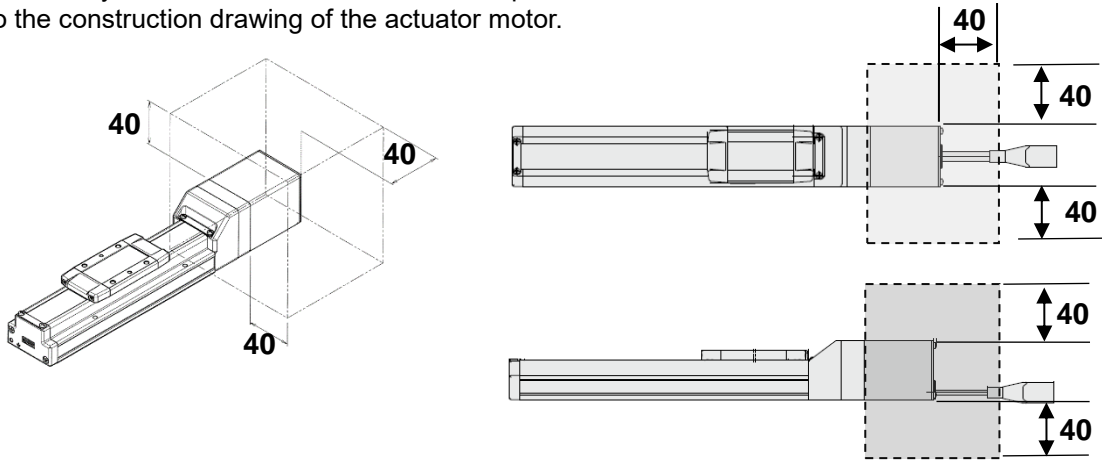

Air cylinder installation with an auto switch is forbidden in the shaded area.



## 4. Initial Setting

### 4.1 Switch (STATION NO., B RATE)

Set the CC-Link address and the CC-Link communication speed by the rotary switch. The table below shows functions of switches.

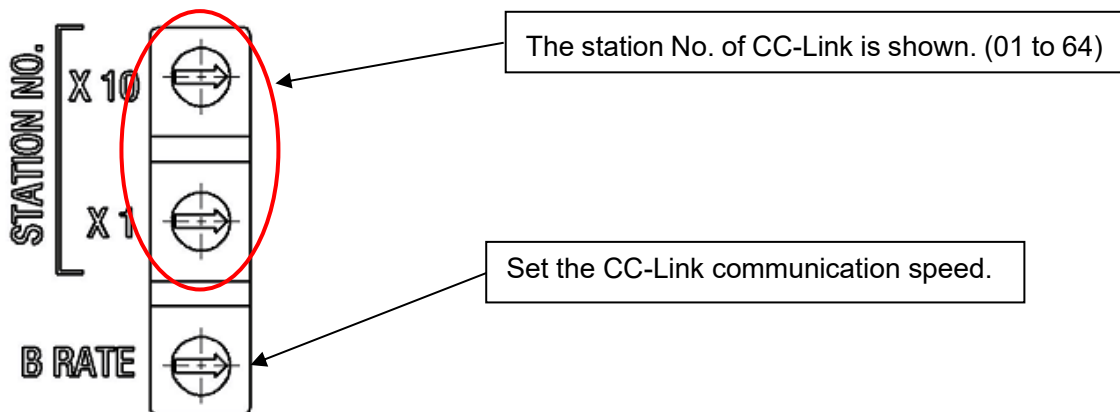

#### ● STATION NO.

Switch name	Set range	Description
STATION NO. (X10)	01 to 64	Set upper bits of the station.
STATION NO. (X1)		Set lower bits of the station.

The CC-Link address setting at the time of the factory shipment is set in "01".

#### ● B RATE switch

B RATE	CC-Link communication speed
9	Reset of Occupied number of stations *1)
8	No used
:	
5	
4	10Mbps
3	5Mbps
2	2.5Mbps
1	625kbps
0	156kbps

\*1) In case of set point = 1 of Occupied number of stations:  
The set point of Occupied number of stations is returns to "2" as delivered by applying the power at the state of B RATE = 9.

The communication speed of CC-Link setting at the time of the factory shipment is set in "0" (156kbps).

Example) When 3 controllers tie as follows by 2 stations occupation (The communication speed of CC-Link is 10Mbps)

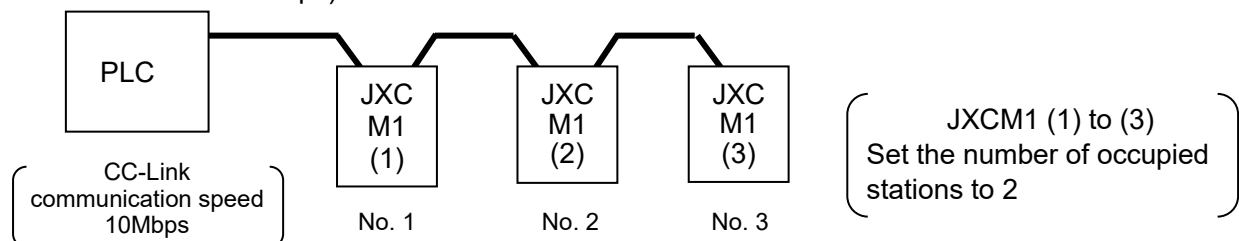

- (1) Since the CC-Link communication speed of the PLC is 10 Mbps, set the B RATE switch for all controllers to 4 (10 Mbps).
- (2) Set the controller's STATION NO. (for the PLC, set the CC-Link station No. address to 0.)
- Controller 1: For LECPMJ (1), set the CC-Link station No. address = 1.  
(STATION NO. (X10)=0, STATION NO. (X1)=1)
- Controller 2: For LECPMJ (2), set the CC-Link station No. address = 3, which is calculated by adding 2 to the CC-Link station No. address of LECPMJ (1) (= 1).  
(STATION NO. (X10)=0, STATION NO. (X1)=3)
- Controller 3: For LECPMJ (3), set the CC-Link station No. address = 5, which is calculated by adding 2 to the CC-Link station No. address (= 3) of LECPMJ(2).  
(STATION NO. (X10)=0, STATION NO. (X1)=5)

## 4.2 Parameter Setting

Set the parameter of occupied number of stations and operation setting at the time of the communication error of JXCM1. The set item is shown below.

- Occupied number of stations setting

Set Occupied number of stations in "Optional setting 1" of basic parameter item.

Optional setting 1	Mode	Occupied number of stations
1	Single numerical data instructions	1 stations
2 (initial value)	Half numerical data instructions	2 stations
4	Full numerical data instructions	4 stations

Please refer to "9. Mode" for details of each mode

- Operation setting of CC-Link at the time of the communication error

Set the operation of CC-Link at the time of the communication error in "Undefined parameter No.11" of basic parameter item.

Undefined parameter No.11	Output the data to control unit
0 (initial value)	HOLD
10	Alarm Stop

Please refer to "11.2 Basic parameter" for details of each parameter.

## 4.3 PLC Setting

et PLC that become the master station.

Use a PLC that supports CC-Link Ver. 1.10 or Ver. 2.00.

Show a case with CC-Link system master local unit (Q Series) of Mitsubishi for the example about setting.

PC series: QCPU (Q mode), PC type: Q00UJ

- Initial addresses of Remote I/O (Rx, Ry) and Remote register (RW<sub>r</sub>, RW<sub>w</sub>), etc.

The PLC memory address shown in “**10. Memory assignment**” becomes the address when doing the setting as the following list. Please set it according to the operating environment.

Example of setting the initial address

	Initial addresses
Remote input (Rx)	X1000
Remote output (Ry)	Y1000
Remote register (RW <sub>r</sub> )	W0
Remote register (RW <sub>w</sub> )	W1000
Special relay (SB)	SB0
Special register (SW)	SW0

- Station information setting

Set Occupied number of stations of JXCM1 which connected to the PLC.

Please set the value same as Occupied number of stations of “Optional setting 1” of Basic parameter.

Occupied number of stations of LECPMJ is set in “2” for shipment.

Example of setting the station information

Station classification	Occupied number of stations
Remote device station	2 stations occupation

- Mode setting

Set the Ver.1 mode.

- Communication speed

Set the same value of communication speed as the value of “**4.1 Switch (STATION NO., B RATE)**”

Please refer to the manual of PLC which is using for details of the setting.

## 5. External Connections

An example of standard wiring of the controller is shown for each connector.

### 5.1 PWR: Power supply connector

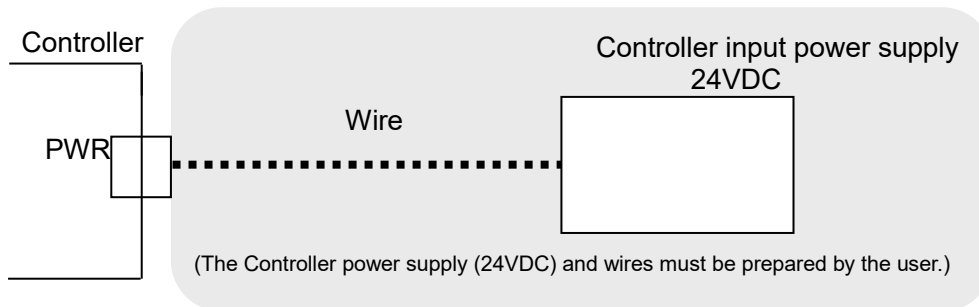

Refer to [6. Details of Power supply plug](#) for wiring.

### ⚠ Caution

Do not use an inrush current limited type of power supply for the controller.

### 5.2 MOT: Motor connector, ENC: Encoder connector

Connect the controller and the electric actuator with the actuator cable (LE-CE-#-#).

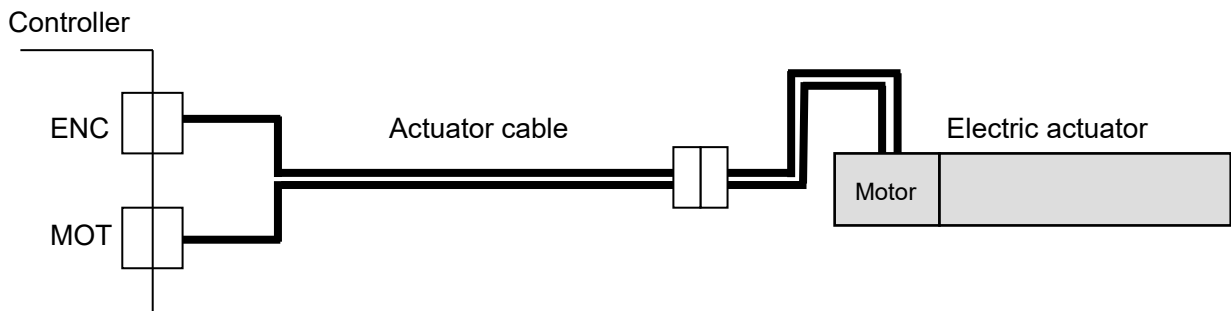

### 5.3 SI: Serial I/O Connector

#### (1) Connecting the teaching box

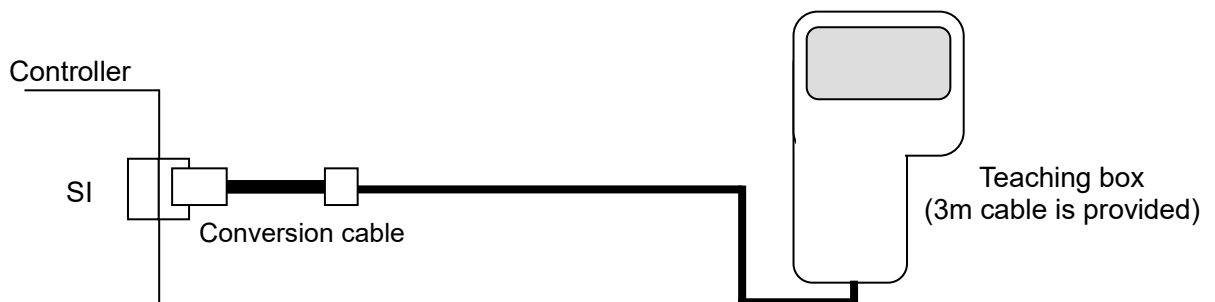

## (2) Connection with a PC

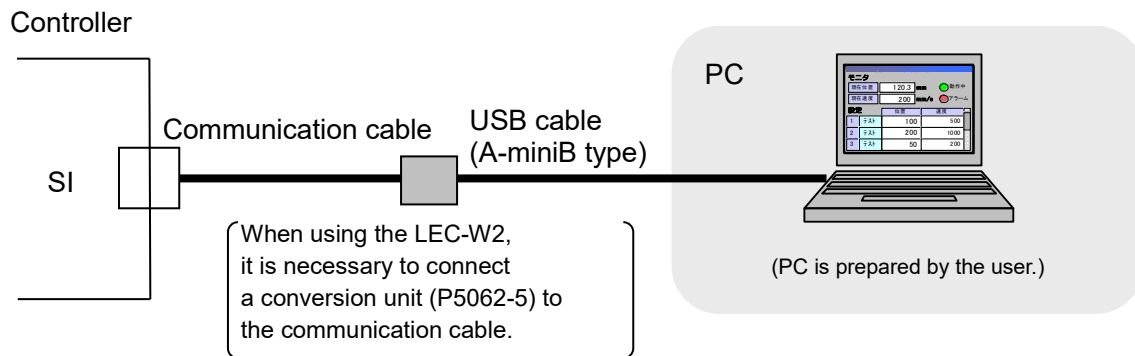

## 5.4 CC-Link communication connector

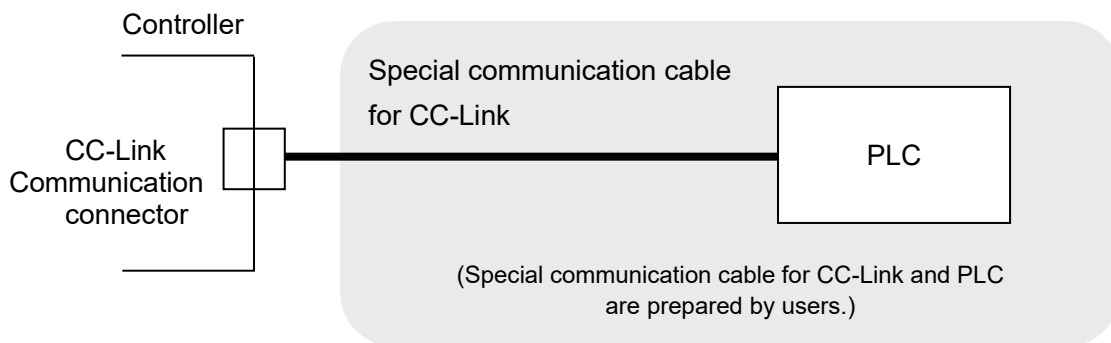

For the wiring method, refer to "**7. Communication Plug Connector**".

## 6. Details of Power Supply Plug

### 6.1 Power supply plug specifications

The specifications of the power supply plug supplied with the controller are shown below.

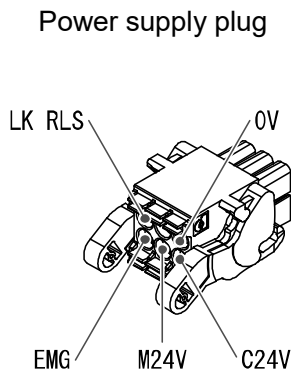

Pin No.	Terminal	Function	Functional explanation
1	C24V	Power supply (+)	The positive control power.
2	M24V	Motor power (+)	The positive power for the actuator motor to be supplied via the controller.
3	EMG	Stop (+)	The positive power for Stop signal
4	0V	Common power (-)	The negative common power for M24V, C24V, EMG and LK RLS.
5	-	NC	N/A
6	LK RLS	Unlocking (+)	The positive power for lock release.

□ Equivalent to Phoenix Contact: DFMC1, 5/3-ST-LR

### 6.2 Electrical Wiring Specifications

Prepare the electrical wiring according to the following specifications (to be prepared by the user).

Item	Specifications
Applicable wire size	Single, stranded wire → AWG20 (0.5 mm <sup>2</sup> ) *The rated temperature of the insulation coating should be 60°C or more. The O.D. should be ø2.5 mm or less.
Stripped wire length	 ø2.5 mm or less      8mm

### ⚠ Caution

Do not connect multiple wires to one terminal.

Arrange wiring so that conductors of each terminal do not contact other lines.

After wiring the power supply plug, connect it to PWR power connector of the controller.

Refer to [6.3 Power Supply Plug Wiring](#) for wiring.

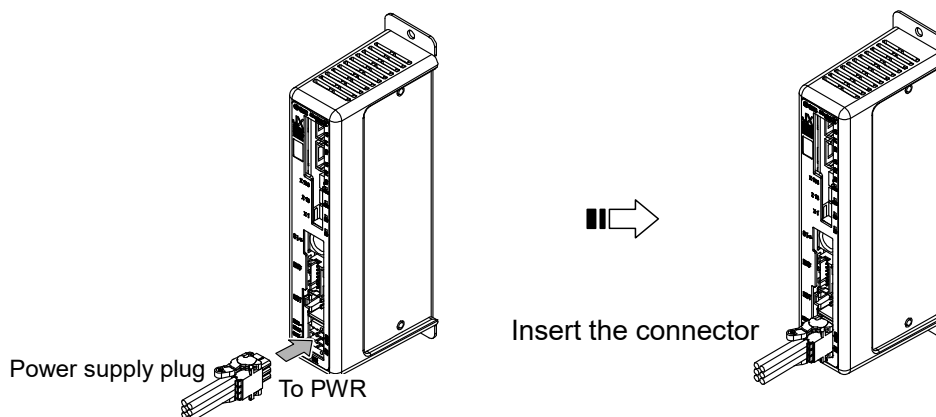

## 6.3 Power Supply Plug Wiring

Connect the power supply plug to the 24VDC controller power supply according to instructions (1) (2) and (3) and then insert it into the PWR connector of the controller.

### (1) Wiring of power supply (C24V, M24V, 0V)

Connect the positive of the 24VDC controller power supply to the C24V and M24V and connect the negative of that power supply to the 0V terminal.

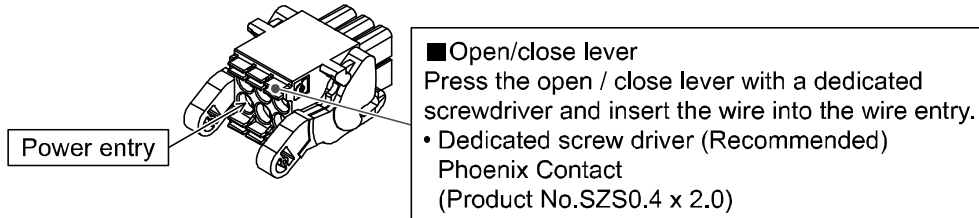

### (2) Wiring of the stop switch (EMG)

Stop switch must be installed by the user to stop the actuator in abnormal situations.

Refer to [6.4 Wiring of shutdown circuit for wiring](#).

### (3) Wiring of the lock release (LK RLS)

Install an unlocking switch for adjustment or recovery during an emergency of the locking actuator.

\* Switch (24V DC, contact capacity 0.5A or more) is provided by customer.

One terminal of the lock release switch should be connected to the 24VDC power supply and the other should be connected to the LK RLS terminal. When this is switched on, the lock will be released.

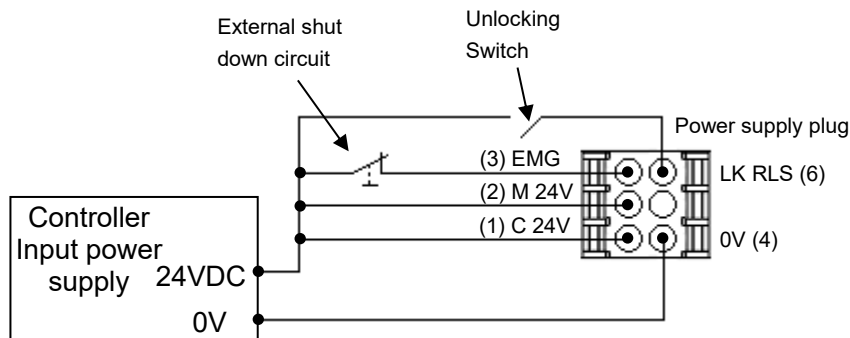

## ⚠ Caution

- (1) Do not use a power supply with "inrush-current control" for the controller power supply.
- (2) It is unnecessary to connect LK RLS terminal when the actuator does not have locking mechanism.
- (3) The LK RLS terminal is only used for adjustment and emergency return. It must not be energized during normal operation.

## 6.4 Wiring of shutdown circuit

The actuator stops its operation when the external shutdown switch or the shutdown switch of the teaching box is activated.

### (1) Example circuit 1- Single controller with teaching box

When the controller recognizes the connection of the teaching box, the shutdown of the teaching box is activated.

(Circuit example)

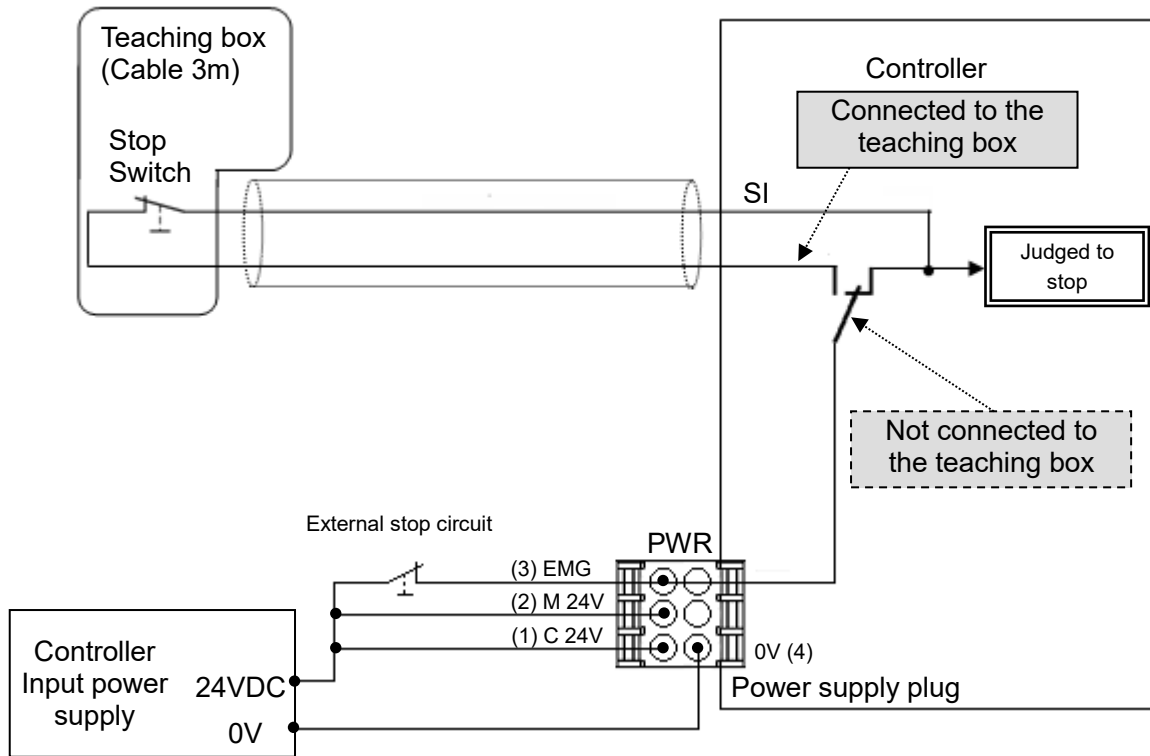

### Warning

The teaching box's stop switch is effective only for the controller that is connected with it.



**(2) Stop (relay contact (1))**

If the system where this controller is installed has a stop circuit for the whole system, or if the system has multiple controllers with individual power supply, relay contacts should be made between the 24VDC controller power supply and the EMG terminal of the power supply plug.

(Circuit example)

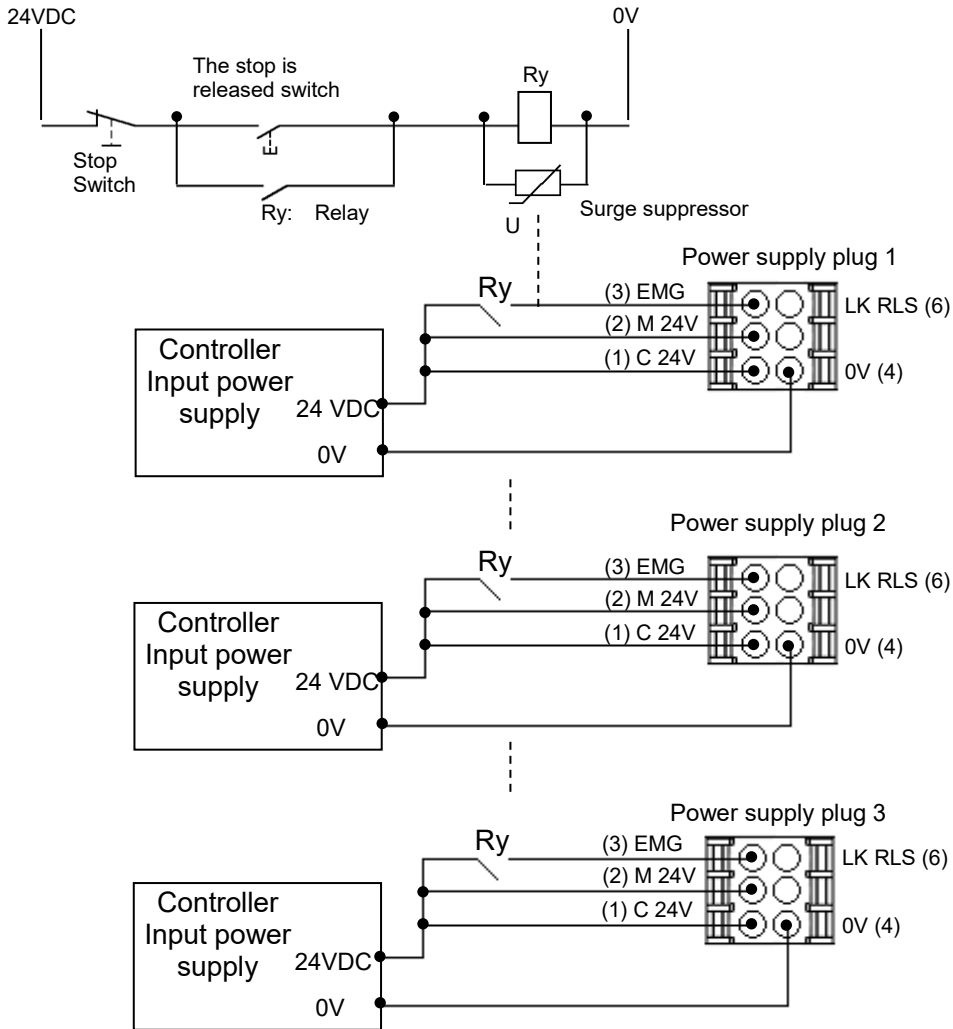

**⚠ Caution**

When shutdown is input, the controller stops with maximum deceleration, then the motor is turned OFF.

### (3) Motor power shutdown (relay contact (2))

If it is necessary to have a circuit to shutdown the motor power externally, relay contacts should be made between the 24VDC controller power supply and the M24V and EMG terminal of the power supply plug.

(Circuit example)

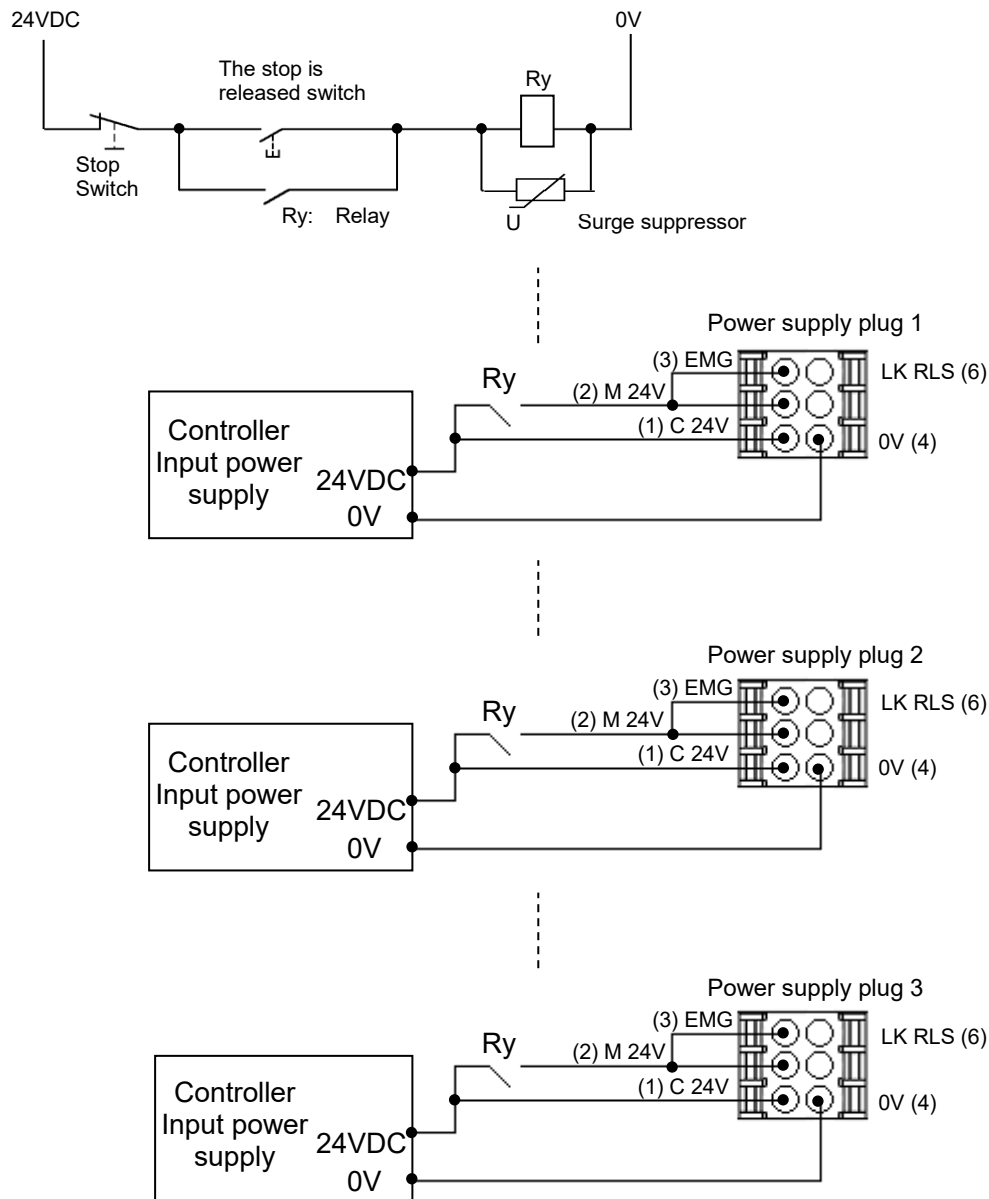

### Warning

- (1) Relay contacts should be made between the 24VDC controller power supply and the M24V and EMG terminal of the power supply plug. The actuator may make unexpected movement.
- (2) Do not perform return to origin (SETUP) when motor drive power (M24V) is disconnected. The controller cannot recognize the correct origin point if a return to origin instruction is made with the motor drive power (M24V) disconnected.
- (3) Do not energize the LK RLS terminal while the motor drive power (M24V) is disconnected.

# 7. Communication Plug Connector

## 7.1 Wiring

The communication plug connector specification of the optional product is shown below.

Straight type

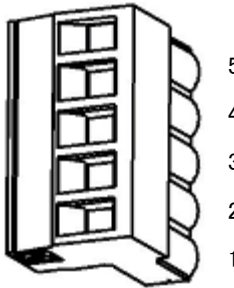

LEC-CMJ-S

Manufactured by Phoenix Contact  
Part no: MSTB2,5/5-ST-5,08 AU

T-Branched type

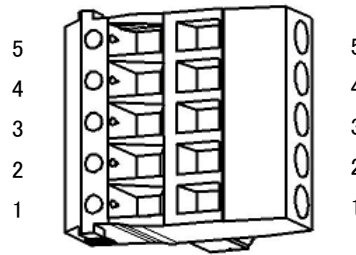

LEC-CMJ-T

Manufactured by Phoenix Contact  
Part no: TMSTBP2,5/5-ST-5,08 AU

No	Designation	Description
1	DA	CC-Link communication line A
2	DB	CC-Link communication line B
3	DG	CC-Link ground line
4	SLD	CC-Link shield
5	FG	Frame ground

CC-Link system has different terminal resistance to connect depending on used cables.

Type of cable	Resistance
Communication cable for CC-Link	110Ω±5% 1/2W
CC-Link dedicated high-performance cable	130Ω±5% 1/2W

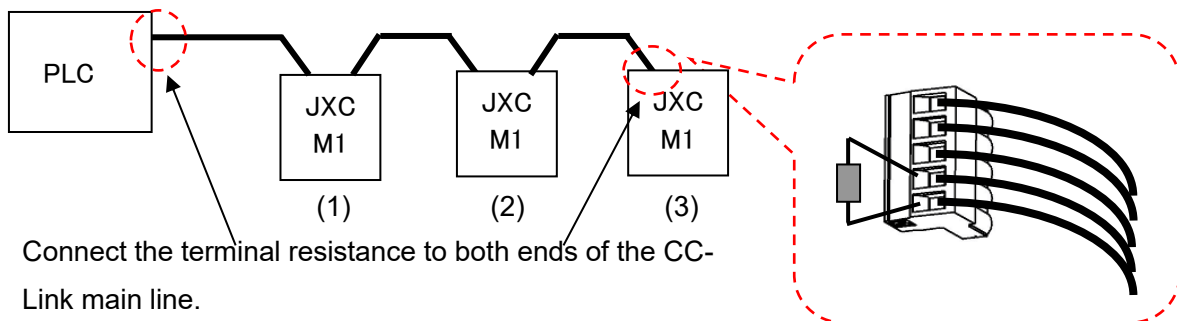

Connect the terminal resistance to both ends of the CC-Link main line.

Prepare a terminating resistor to suit your application.

## 7.2 Electric wire specification

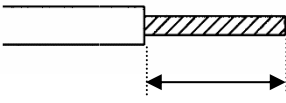
Item	Specifications
Applicable wire size (Single line, stranded wire)	AWG 24 to 12 (0.2 to 2.5mm <sup>2</sup> ) The rated temperature for the insulation coating: 60°C or more
Stripped section length	 LEC-CMJ-S: 7mm LEC-CMJ-T: 10mm

## 7.3 Wiring of communication plug connector

Please wire the CC-Link communication cable to the communication plug connector, and then insert it into CN5 connector of controller.

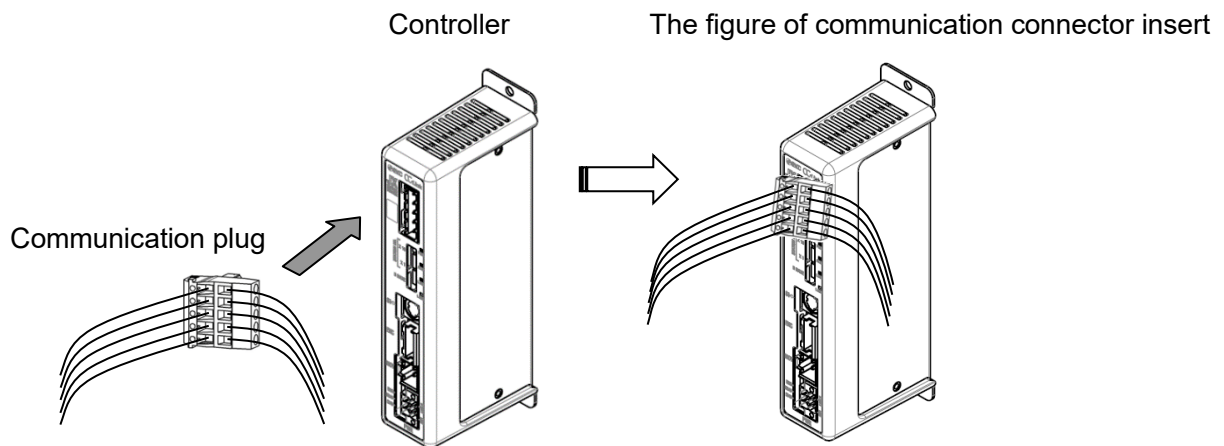
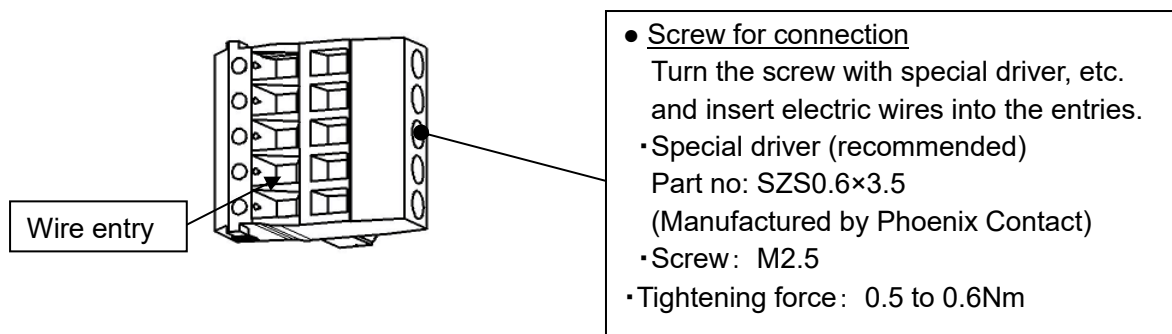

## 8. LED display

### 8.1 LED display

Refer to the table below for details of the LED status.

LED	Details		
PWR	Power supply and EEPROM writing status	OFF	Power is not supplied
		Green LED is ON	Power is supplied
		Green LED is flashing	EEPROM writing
ALM	Controller alarm status.	OFF	Normal operation
		Red LED is ON	Alarm generated
L ERR	Error status (CC-Link)	OFF	Normal operation
		Red LED is ON	Error is generated
		Red LED is flashing	
L RUN	CC-Link communication status.	OFF	Communication disconnected
		Green LED is ON	Communicating
		Green LED is flashing	Error is generated

### 8.2 LED and Controller Status

Refer to the table below for the LED and the controller status.

Controller status		LED description			
		PWR	ALM	L ERR	L RUN
When power is supplied		-	-	LED is OFF	LED is OFF
CPU ROM · RAM check error for CC-Link communication		-	-	Red LED is ON	Green LED is ON
When CC-Link communication is normal		-	-	LED is OFF	Green LED is ON
The setting of Rotary switch is changed when supplying of power		-	-	Red LED is flashing	LED is OFF
CC-Link communication area	CC-Link communication stop	-	-	LED is OFF	LED is OFF
	CC-Link CRC error	-	-	Red LED is ON	LED is OFF
	STATION No. error	-	-	Red LED is ON	Green LED is flashing
	Communication speed error (unused range)	-	-	Red LED is flashing	Green LED is ON
	WDT time-out error	-	-	Red LED is flashing	Green LED is flashing
Motor controller	Controller alarm generated	LED is OFF	Red LED is ON	-	-
	Controller system error generated	Green LED is ON	Red LED is ON	-	-
	Writing to controller EEPROM	Green LED is flashing	-	-	-

—: The LED display is unrelated

### Caution

Do not turn OFF the power supply for the controller or disconnect and connect the cable while the data is being written to EEPROM (PWR LED (green) is flashing).

\* Possibility of incorrect / corrupt data (step data, parameter)

## 9. Mode

### 9.1 Outline

This controller has 3 types of operation mode (Single numerical data instructions, Half numerical data instructions, Full numerical data instructions). These modes can be changed by registering the occupied number of Stations with basic parameter "Option setting 1" of the controller.

The following describes the details for each mode.

Mode name	Content
Single numerical data instruction mode	When specifying the preset step data No. for operation, it is possible to numerically specify the step data "Movement MOD" and one other item directly from the PLC.
Half numerical data instruction mode	When specifying the preset step data No. for operation, it is possible to numerically specify up to six step data items ("Movement MOD", "Speed", "Position", "Acceleration", "Pushing speed", "Pushing force", "Deceleration", and "Trigger LV") directly from the PLC.
Full numerical data instruction mode	It is possible to numerically specify all step data items (up to 12 items) ("Movement MOD", "Speed", "Position", "Acceleration", "Pushing speed", "Pushing force", "Deceleration", "Trigger LV", "Moving force", Area 1", "Area 2", and "In position") directly from the PLC.

Function of each mode setting that which be executed is shown below

Mode	Referent	Single numerical data instructions	Half numerical data instructions	Full numerical data instructions
Option setting 1 <sup>*1)</sup>	11.2	1	2	4
Occupied number of stations	-	1	2	4
Step No. instructions operation function	9.2	○		
Monitor function of Position/Speed	9.3	○		
Numerical data instructions operation	9.4	○		
The number of Numerical data modifiable items		1	6	12
Step data editing function	9.5	○ <sup>*2)</sup>		
Maximum product to be connected	-	42	32	16

\*1) At the time of the factory shipment, "Option setting 1" of the controller is set in "2".

Please refer to "**9.4 Numerical data instructions operation function**" for the number of Numerical data modifiable items in each mode

\*2) It is possible to edit it from Teaching box / Controller setting software for "Single numerical data instructions". It is possible to edit it from Teaching box / Controller setting software and PLC (CC-Link) for "Half numerical data instructions" and "Full numerical data instructions".

### 9.2 Step No. instructions operation function

It operates by the memory which corresponds to the Input / Output ports of DRIVE signal and INP signal, etc., and the operating state can be monitored by PLC (master).

The memory which corresponds to the Input / Output ports of DRIVE signal and INP signal, etc. can be operated by Rx, Ry of Remote IO.

When operate with the operating data which are registered beforehand, select Step data No. of operating data in Ry00 to 05: IN0 to IN5 of remote IO and start operating with DRIVE signal.

Please refer to "**15.1 Operating procedure of Step No. instructions operation function**" for details of the operating procedure.

### 9.3 Position / speed monitor

The current position and the current speed of the information of the controller can be read by turning on controller control flag “RWw0, bit0: Setting read numerical data “of the remote register.

### 9.4 Operation by numerical instruction

The electric actuator operates according to the value that specifying the position and the speed, etc. for the controller. The value that can be instructed in each mode is shown below. The item except Numerical data instructions refers to the step data which are registered in the controller.

And please do the operation similar to Step No. instructions operation for the preparation (SVON and return to origin) of operation.

- Modifiable step data item in each mode

Mode	Item											
	Move	Speed	Position	Accel	Pushing Sp	Pushing F	Decel	Trigger LV	Moving F	Area1	Area2	In pos
Single numerical data instruction	○	○ *1)										
Half numerical data instruction	○	○	○	○ *2)		○	○ *2)		○	○	○	○
Full numerical data instruction	○	○	○	○	○	○	○	○	○	○	○	○

○: It is possible to change. -: It is not possible to change.

\*1) Only one item can be changed from the corresponding item.

\*2) Only one item can be changed from the corresponding item.

Please refer to “15.2 Operating procedure of Numerical data instructions operation function” for details of the operating procedure

## 9.5 Data editing function

A function to read and write the step data and number of occupied stations in the controller's built-in microcomputer as well as read the state data to/from CC-Link. Please refer to the instruction manual for the teaching box, or to the controller setting software for details of the function for editing the step data and other items.

Please refer to "9.5 Data editing function" for setting Sub Function (instruction code), Address (reading / writing start address), and DATA (change data) when data is rewritten.

Please refer to "15.3 The operating procedure of Data editing function" for details of the operating procedure.

### Data editing function

- Sub Function (instruction code)

The instruction code, the function, and the setting data which can be used in this controller are shown below.

Instruction code (Sub Function)	Function	Address	DATA (Sending)		DATA (Receiving)	
			DATA (H)	DATA (L)	DATA (H)	DATA (L)
(01)h	Data returning for 1word	Reading start number	/	/	Data (1 word)	/
(02)h	Data returning for 2word	Reading start number	/	/	Data (2 word Upper side)	Data (2 word lower side)
(11)h	Data writing for 1word	Writing start number	Data (1 word)	/	Data (1 word)	/
(12)h	Data writing for 2word	Writing start number	Data (2 word Upper side)	Data (2 word lower side)	Data (2 word Upper side)	Data (2 word lower side)

- Address (reading / writing start address)

This specifies the controller memory address map of the LECPMJ's built-in microcomputer, which can edit data.

The controller memory address shown in the following is a hexadecimal notation.

- State data address

Controller memory address	Name	Word	Unit
(9000)h	Current position	2	0.01mm
(9002)h	Current speed	1	1mm/s
(9003)h	Current Force	1	1%
(9004)h	Target position	2	0.01mm
(9006)h	Movement step data No.	1	—
(9008)h	Alarm 2 (high-level byte) / Alarm 1 (low-level byte)	1	—
(9009)h	Alarm 4 (high-level byte) / Alarm 3 (low-level byte)	1	—



•Basic parameter addresses

Controller memory address	Name	Words	Input range	Unit
(0000)h	Controller ID	Upper-level	1 to 32	—
	I/O pattern	Lower-level	Fixed value	—
(0001)h	Acceleration/deceleration pattern	Upper-level	Fixed value	—
	S-motion rate	Lower-level	*1)	—
(0002)h	Stroke (+)	2	*1)	0.01 mm
(0004)h	Stroke (-)	2	*1)	0.01 mm
(0006)h	Maximum speed	2	*1)	1 mm/s
(0007)h	Maximum acceleration speed	1	*1)	1 mm/s <sup>2</sup>
(0008)h	Default positioning range	2	*1)	0.01 mm
(000a)h	Origin offset	2	*1)	0.01 mm
(000c)h	Maximum pushing force	Upper-level	*1)	1%
	Parameter protection	Lower-level	1,2	—
(000d)h	Enable SW	Upper-level	1,2,3	—
	-	Lower-level	Fixed value	—
(000e)h	Unit name	8	Fixed value	—
(0016)h	W area output end 1	2	*1)	0.01 mm
(0018)h	W area output end 2	2	*1)	0.01 mm
(001a)h	ORG Correct	1	Fixed value	—
(001c)h	Sensor type	1	Fixed value	—
(001d)h	Optional setting 1 (Number of	1	1,2,4	—
(001e)h	Undefined parameter 11 (Operation setting when there is a CC-Link communication error)	1	0,10	—
(001f)h	Undefined parameter 12	1	Fixed value	—

This parameter becomes effective after restarting.

•Return-to-origin parameter addresses

Controller memory address	Name	Words	Input range	Unit
(0020)h	Return-to-origin direction	Upper-level	1,2	—
	Return-to-origin mode	Lower-level	1,2	—
(0021)h	Origin pushing-force limit	Upper-level	*1)	—
	Return-to-origin time	Lower-level	Fixed value	1 ms
(0022)h	Return-to-origin speed	1	*1)	1 mm/s
(0023)h	Return-to-origin	1	*1)	1 mm/s <sup>2</sup>
(0024)h	Creep speed	1	Fixed value	1 mm/s
(0025)h	Origin sensor [ORIG	Upper-level	0 to 2	1 mm/s <sup>2</sup>
	ORIG switch direction	Lower-level	Fixed value	—
(0026)h	Undefined parameter 21	1	Fixed value	—

•JOG motion data addresses (motion parameter items)

Controller memory address	Name	Word	Setting data range	Unit
(0030)h	JOG speed	1	*1)	1mm/s
(0031)h	JOG acceleration	1	1 to "Max ACC/ DEC" of the basic parameter	1mm/s <sup>2</sup>
(0032)h	JOG deceleration	1	1 to "Max ACC/ DEC" of the basic parameter	1mm/s <sup>2</sup>
(0033)h	JOG thrust	1	*1)	1%
(0034)h	Fixed distance	2	"Stroke (-)" to "Stroke (+)" of the basic parameter	0.01mm

•Step data address

Controller memory address	Name	Word	Setting data range	Unit
(0400)h to (040F)h	Step data (No.0)	16	—	—
(0410)h to (041F)h	Step data (No.1)	16	—	—
(0420)h to (042F)h	Step data (No.2)	16	—	—
⋮	⋮	⋮	⋮	⋮
(07F0)h to (07FF)h	Step data (No.63)	16	—	—

Please refer to the example of the following in a detailed address of each step data.

Example) Address for step data No.0

Controller memory address	Name	Word	Setting data range	Unit
(0400)h	Movement MOD	1	0=Disable 1=ABS 2=INC	—
(0401)h	Speed	1	*1)	1mm/s
(0402)h	Position	2	"Stroke (-)" to "Stroke (+)" of the basic parameter	0.01mm
(0404)h	Acceleration	1	1 to "Max ACC / DEC" of the basic parameter	1mm/s <sup>2</sup>
(0405)h	Deceleration	1	1 to "Max ACC / DEC" of the basic parameter	1mm/s <sup>2</sup>
(0406)h	Pushing force	1	*1)	1%
(0407)h	Trigger LV	1	*1)	1%
(0408)h	Pushing speed	1	*1)	1mm/s
(0409)h	Moving force	1	*1)	1%
(040A)h	Area 1	2	"Stroke (-)" to "Stroke (+)" of the basic parameter	0.01mm
(040C)h	Area 2	2	"Stroke (-)" to "Stroke (+)" of the basic parameter	0.01mm
(040E)h	In position	2	*1)	0.01mm

\*1) The input range which can be set differs depending on the electric actuator type.

Refer to the electric actuator's instruction manual for details.

## 10. Memory map

### 10.1 Remote IO (Rx and Ry)

List and details of remote IO according to the mode are shown as follows

Address Rx00、Ry00 corresponds to initial address of Remote IO memory allocated in masters.

#### (1) Controller → Higher level device [IN] (Remote to Master)

PLC memory address	Single numerical data instructions	Half numerical data instructions	Full numerical data instructions
Rx00 to Rx0F	Input port equivalency signal	Input port equivalency signal	Input port equivalency signal
Rx10 to Rx1F	CC-Link system area	(No used)	(No used)
Rx20 to Rx2F	/		
Rx30 to Rx3F		CC-Link system area	
Rx40 to Rx4F		/	
Rx50 to Rx5F			
Rx60 to Rx6F			
Rx70 to Rx7F			CC-Link system area

#### (2) Higher level device → Controller [OUT] (Master to Remote)

PLC memory address	Single numerical data instructions	Half numerical data instructions	Full numerical data instructions
Ry00 to Ry0F	Output port equivalency signal	Output port equivalency signal	Output port equivalency signal
Ry10 to Ry1F	CC-Link system area	(No used)	(No used)
Ry20 to Ry2F	/		
Ry30 to Ry3F		CC-Link system area	
Ry40 to Ry4F		/	
Ry50 to Ry5F			
Ry60 to Ry6F			
Ry70 to Ry7F			CC-Link system area

(3) Controller → Higher level device [IN] (Remote to Master)

PLC memory address	Signal name			Description												
	Single numerical data instructions	Half numerical data instructions	Full numerical data instructions													
00	OUT0			When the operation is started and “DRIVE” is turned OFF, the step No. executed by “DRIVE” will be refreshed/updated by the combination of “OUT0” to “OUT5” (binary digit). (E.g.) Step data No.3 is output <table border="1" style="width: 100%; text-align: center;"> <tr> <td>OUT5</td> <td>OUT 4</td> <td>OUT 3</td> <td>OUT 2</td> <td>OUT 1</td> <td>OUT 0</td> </tr> <tr> <td>OFF</td> <td>OFF</td> <td>OFF</td> <td>OFF</td> <td>ON</td> <td>ON</td> </tr> </table> <div style="text-align: center; background-color: #cccccc; padding: 5px;"><b>⚠ Caution</b></div> (1) When “RESET” is turned ON, these signals turn OFF. (2) During the alarm, these signals output the alarm group. (3) During the pushing operation, if the actuator runs over the defined pushing width, these signals turn OFF.	OUT5	OUT 4	OUT 3	OUT 2	OUT 1	OUT 0	OFF	OFF	OFF	OFF	ON	ON
OUT5	OUT 4	OUT 3	OUT 2		OUT 1	OUT 0										
OFF	OFF	OFF	OFF		ON	ON										
01	OUT1															
02	OUT2															
03	OUT3															
04	OUT4															
05	OUT5															
06	—			—												
07	—			—												
08	BUSY			This signal is ON during the movement of the electric actuator (during the positioning operation, etc.). <div style="text-align: center; background-color: #cccccc; padding: 5px;"><b>⚠ Caution</b></div> During the pushing operation without movement (no movement but the electric actuator generating the pushing force), BUSY is OFF. BUSY signal stays on for 50ms or longer after operation starts.												
09	SVRE			When the servo motor is OFF, “SVRE” is OFF. When the servo motor is ON, “SVRE” is ON.												
0A	SETON			When the actuator is in the SETON status (the position information is established), this signal turns ON. When the position status is not established, this signal is OFF.												

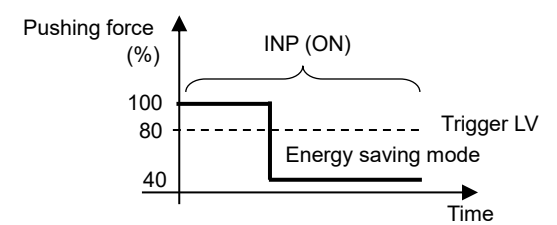
0B	INP			<p>The condition when "INP" turns ON depends on the electric actuator action.</p> <ul style="list-style-type: none"> <li>•Return to origin Turns ON at the origin when within the <math>\pm</math>"default in position" in the Basic parameters.</li> <li>•During positioning operation Turns ON when the current position is within "Step data position <math>\pm</math> positioning range".</li> <li>•During pushing operation Turns ON when the pushing force exceeds the value set in the step data "Trigger LV".</li> </ul> <p style="text-align: center;"><b>⚠ Caution</b></p> <p>After the pushing operation is completed, even if it switches automatically to energy saving mode, "INP" remains ON. When movement starts again from the pushing stopped state, pushing operation is repeated with the normal pushing force. E.g.) Step data "force" is 100% Step data "Trigger LV" is 80%, The energy saving setting of the actuator is 40%.<sup>*1)</sup></p> <p>*1) The actuator model determines the energy saving settings. Please refer to the manual of the electric actuator for more details.</p> 
0C	AREA			<p>When the actuator is within the output range between Area1 and Area2 in the step data, this signal will be turned ON. The range changes depending on the active step data.</p>
0D	WAREA			<p>When the actuator is within the output range between "W area 1 and W area 2" of basic parameter, this signal will be turned ON.</p>
0E	ESTOP			<p>During activation of the Teaching Box stop switch, this signal is ON. During the normal operation, it is OFF. This is synchronized to the input for the EMG signal on the controller PWR connector.</p>
0F	ALARM			<p>Alarm generated when problems occur to the electric actuator or its controlling status. It is OFF when there are no alarms.ON in alarm condition.</p>
10 to 1A	CC-Link system area	(No used)	(No used)	—
1B	Remote station READY			<ul style="list-style-type: none"> <li>• Only at Single numerical data instructions During the normal status, this terminal is OFF, during the abnormal status (The WDT time-out of CPU is generated) this is ON.</li> </ul>
1C to 1F	CC-Link system area			—
20 to 2F	/			—
30 to 3A	CC-Link system area			—

3B		Remote station READY	(No used)	● Only at Half numerical data instructions The content of Remote station READY is as same as at Single numerical data instructions. Please refer to the content of Rx1B.
3C to 3F		CC-Link system area		—
40 to 6F				—
70 to 7A			CC-Link system area	—
7B			Remote station READY	● Only at Full numerical data instructions The content of Remote station READY is as same as at Single numerical data instructions. Please refer to the content of Rx1B.
7C to 7F			CC-Link system area	—

The table below shows the changes in the signal with respect to the state of the controller.

Status	Output signal	BUSY	INP	SVRE	Lock	SETON	OUT0 to OUT5
Servo is OFF when the controller is powered for the first time. *1)		OFF	OFF	OFF	Lock	OFF	OFF
Servo is ON when the controller is powered for the first time		OFF	OFF	ON	Unlock	OFF	OFF
During stopping when "SVON" is OFF after turning ON the power supply to the controller		OFF	OFF*2)	OFF	Lock	ON*3)	ON*4)
During stopping when "SVON" is ON after turning ON the power supply to the controller		OFF	ON*5)	ON	Unlock	ON*3)	OFF
During returning to origin		ON	OFF	ON	Unlock	OFF	OFF
The actuator is at the origin. On completion of "SETUP"		OFF	ON*5)	ON	Unlock	ON	OFF
During movement by positioning/pushing operation		ON	OFF	ON	Unlock	ON	ON*6)
The actuator is paused by "HOLD"		OFF	OFF	ON	Unlock	ON	ON*6)
On completion of the positioning operation		OFF	ON*2)	ON	Unlock	ON	ON*6)
Stopped due to pushing a workload in pushing operation		OFF	ON	ON	Unlock	ON	ON*6)
Stopped due to no detection of workload during a pushing operation		OFF	OFF	ON	Unlock	ON	OFF
During stopping when "SVON" is OFF after returning to the home position		OFF	OFF*2)	OFF	Lock	ON	ON*4)
EMG signal stop from the PWR connector when the actuator is at the origin		OFF	OFF*2)	OFF	Lock	ON	OFF

\*1) Alarm "Absolute encoder ID Alarm error" is cancelled.

\*2) The signal turns ON when the actuator is "In position" according to the step data.

\*3) Return to origin completed.

\*4) Retains the previous state.

\*5) The signal turns ON when the actuator is within the range defined in the basic parameter setup.

\*6) The output is updated on the transition (ON -> OFF) of the DRIVE input signal.

**(4) Higher level device → Controller [OUT] (Master to Remote)**

PLC Memory address	Signal name			Description												
Ry	Single numerical data instructions	Half numerical data instructions	Full numerical data instructions													
00		IN0		Bit no. to specify the step data (Specify the number by combining On/Off of the terminals.) E.g.) Step data No. 3 has been assigned. <table border="1" style="margin-left: 20px;"> <tr> <td>IN5</td><td>IN4</td><td>IN3</td><td>IN2</td><td>IN1</td><td>IN0</td> </tr> <tr> <td>OFF</td><td>OFF</td><td>OFF</td><td>OFF</td><td>ON</td><td>ON</td> </tr> </table>	IN5	IN4	IN3	IN2	IN1	IN0	OFF	OFF	OFF	OFF	ON	ON
IN5	IN4	IN3	IN2		IN1	IN0										
OFF	OFF	OFF	OFF		ON	ON										
01		IN1														
02		IN2														
03		IN3														
04		IN4														
05		IN5														
06		—		Normally, leave it OFF												
07		—		Normally, leave it OFF												
08		HOLD		If “HOLD” is turned ON during operation, the speed decreases at maximum deceleration set in the basic parameters until the actuator stops. The remaining stroke will be on hold as long as “HOLD” is ON and when “HOLD” is turned OFF, the actuator restarts and travels for the remaining stroke. - When “DRIVE” or “SETUP” is ON <div style="text-align: center;"> </div> <div style="border: 1px solid black; padding: 5px; margin-top: 10px;"> <p style="text-align: center;"><b>⚠ Caution</b></p> <ul style="list-style-type: none"> <li>• As long as HOLD is ON, the DRIVE input will be disabled.</li> <li>• The signals are rendered invalid whilst “HOLD” is in operation.</li> </ul> </div>												
09		SVON		“SVON” signal turns the servo motor ON. When “SVON” is ON, the servo motor will be turned ON. When it is OFF, the servo motor will be turned OFF.												
0A		DRIVE		When “DRIVE” is turned ON, the system scans “IN0” to “IN5” and starts the operation of the actuator. Then, when “DRIVE” is turned OFF, the number of the active step data will be output via the “OUT0” to “OUT5” signals.												
0B		RESET		“RESET” is a signal to reset the alarm and the operation. After “RESET”, the speed decreases at maximum deceleration of the basic parameter until the actuator stops. “INP” and “OUT0” to “OUT5” will be turned OFF (however, if the actuator is stopped within the in-position range, “INP” will turn ON).												
0C		SETUP		When “SVRE” is ON, the “SETUP” operation (return to origin operation) will be performed. During the “SETUP” operation, “BUSY” will turn ON. After completion of the “SETUP” operation, “SETON” and “INP” will turn ON.												

0D	JOG(-)		Jogging in the (-) direction. The electric actuator moves when the signal is ON. Stops when the signal is OFF. When the "FLGTH" (signal for switching Jogging and Inching) is ON, the electric actuator inches toward the (-) side as the "JOG (-)" signal increases. INP output, OUT0 to 5 are OFF after Jogging/ Inching start. INP output, OUT0 to 5 are not turned ON after Jogging/ Inching is completed.	
0E	JOG(+)		Jogging in the (+) direction. Operation is the same as "JOG(-)". with "-" changed to "+"	
0F	FLGTH		Switches the function (Jogging and Inching) of Jogging signal "JOG(-)" and "JOG (+)". Inching starts when this signal is ON and when the Jogging signal is ON. Jogging starts when this signal is OFF. The Inching distance is the value in the operation parameter "Fixed distance".	
10 to 1F	CC-Link system area	(No used)	-	
20 to 2F	/	(No used)		
30 to 3F		CC-Link system area		
40 to 6F		/		(No used)
70 to 7F				CC-Link system area

Valid conditions for input signals

Signal name	SETON output	SVRE output	BUSY output
Conditions			
SETUP input [Return to origin]	—	ON	OFF *1)
DRIVE input [Operation start instruction]	ON	ON	—
JOG (-) , (+) [JOG operation command]	— *2)	ON *3)	OFF

("—" = Does not depend on the ON/OFF state of each output signal)

\*1) The SETUP input will be disabled during the positioning and pushing operation.

\*2) JOG (including Inching) is enabled even before the position is fixed. However, since the stroke limit is not enabled before fixing the position, take extra care not to let the JOG collide with the rotating end.

\*3) When Jogging (including Inching) reaches the stroke limit, the "stroke limit" alarm (052) occurs.

<b>⚠ Caution</b>
SETUP and DRIVE can only be accepted during the above conditions. An alarm will be generated at other times. Make sure to have intervals of 2 times or more of the communication cycle time and maintain the input state for the same period of time.



## 10.2 Remote register (RWr and RWw)

List of remote register according to the mode are shown as follows.

In Half numerical data instructions and Full numerical data instructions the memory assignment is different according to the function to use. The change of Numerical data instructions operation function and Step data editing function uses RWw0, bit1: Setting parameter rewriting.

Address RWr0, RWw0 corresponds to top address of remote register memory allocated in masters.

### (1) Controller → Higher level device [IN] (Remote to Master)

PLC Memory address	Single numerical data instructions	Half numerical data instructions		Full numerical data instructions			
	Numerical data instructions operation function	Numerical data instructions operation function	Data editing function	Numerical data instructions operation function	Data editing function		
RWr0	Controller information flag	Controller information flag	Controller information flag	Controller information flag	Controller information flag		
RWr1	Current position	Current position	Current position	Current position	Current position		
RWr2							
RWr3	Current speed	Current speed	Return of Parameter rewriting	Current speed	Current speed		
RWr4						Current force	Current force
RWr5						Target position	Target position
RWr6							
RWr7		Alarm	Alarm				
RWr8		Alarm	Alarm				
RWr9							
RWr10			Occupation area	Return of Parameter rewriting			
RWr11							
RWr12			Occupation area	Occupation area			
RWr13							
RWr14							
RWr15	Occupation area						

**(2) Higher level device → Controller [OUT] (Master to Remote)**

PLC memory address	Single numerical data instructions	Half numerical data instructions		Full numerical data instructions			
	Numerical data instructions operation function	Numerical data instructions operation function	Data editing function	Numerical data instructions operation function	Data editing function		
RWw0	Controller control / Numerical data flag	Controller control / Numerical data flag	Controller information flag	Controller control / Numerical data flag	Controller information flag		
RWw1	Movement MOD / Start flag	Movement MOD / Start flag	Send of Parameter rewriting	Movement MOD / Start flag	Send of Parameter rewriting		
RWw2	Numerical data instructions data	Speed		Speed			
RWw3		Target position		Target position			
RWw4		Acceleration / Pushing speed		Acceleration			
RWw5		Deceleration / Trigger LV		Deceleration			
RWw6		Pushing force		Occupation area		Pushing force	Occupation area
RWw7						Trigger LV	Occupation area
RWw8			Pushing speed				
RWw9	Moving force						
RWw10	Area 1		Occupation area				
RWw11	Area 2						
RWw12	In position						
RWw13							
RWw14							
RWw15							

“Occupation area” is an area that secured compulsorily by JXCM1. JXCM1 does not exchange data with PLC in “Occupation area”

### (3) Details: Numerical data instructions operation function

- Controller → Higher level device [IN] (Remote to Master)

[Single numerical data instructions]

PLC memory address		RWr Data name		Content															
RWr	bit	Single numerical data instructions																	
0	0	Controller information flag	Return of Occupied number of stations (L)	Current occupied number of stations is shown. <table border="1" style="margin-left: 20px;"> <thead> <tr> <th>H</th> <th>L</th> <th>Occupied number of stations</th> </tr> </thead> <tbody> <tr> <td>0</td> <td>0</td> <td>1 Stations occupied</td> </tr> <tr> <td>0</td> <td>1</td> <td>2 Stations occupied</td> </tr> <tr> <td>1</td> <td>0</td> <td>—</td> </tr> <tr> <td>1</td> <td>1</td> <td>4 Stations occupied</td> </tr> </tbody> </table>	H	L	Occupied number of stations	0	0	1 Stations occupied	0	1	2 Stations occupied	1	0	—	1	1	4 Stations occupied
	H		L		Occupied number of stations														
	0		0		1 Stations occupied														
	0		1		2 Stations occupied														
	1		0		—														
	1		1	4 Stations occupied															
	1		Return of Occupied number of stations (H)																
	2		Sending	After turning Start flag on at Numerical data instructions operation, this terminal will be ON during sending. And this terminal is OFF when the sending is completed or waiting for the sending instruction.															
	3		Sending completed	When the data sending is completed at Numerical data instructions operation, Sending flag will be OFF and this terminal will be ON. Then Start flag turns OFF and this terminal will be OFF.															
	4		READY	It is always ON if the controller has been started normally.															
	5		ALARM flag	An alarm is generated when problems occur with the LECPMJ's internal process or communication with the PLC. OFF during normal condition. ON when an alarm is generated.															
	6		Initial	It is OFF during initial processing. It stays ON once the initial processing is completed.															
	7		Return of the read numerical data	It is ON when reading numerical data. Otherwise it is OFF.															
8 to C	(No used)	—																	
D	Data editing error receiving	When the error occurs in the data editing function, this terminal will be ON with RWr0, bit5: ALARM flag. When RWw0, bit2: Reset is turned on, it is cleared.																	
E	Parameter anomaly detection	When a parameter is invalid, this and the RWr0, bit5: ALARM flag are turned ON. It is turned OFF when the RWw0, bit2: Reset flag is turned ON. Please refer to " <b>17. Alarm Detection for CC-Link Communication</b> " for details.																	
F	The abnormal station detection	When an abnormal station is detected, this and the RWr0, bit5: ALARM flag are turned ON. It is OFF when the RWw0, bit2: Reset flag is ON. Please refer to " <b>17. Alarm Detection for CC-Link Communication</b> " for details.																	
1	F to 0	L	Current position	When the read numerical data is effective, this terminal will output the current position of the electric actuator by 0.01[mm] unit Example) When 800.00[mm] (8000d=13880h) is output RWr1=3880h															
2	F to 0	H																	
3	7 to 0	L	Current speed	When the read numerical data is effective, this terminal will output the current speed of the electric actuator by 1[mm/s] unit Example) When 300[mm/s] (300d=012Ch) is output RWr3=012Ch															
	F to 8	H																	

H=Most Significant Byte or upper word

L=Least Significant Byte or lower word

[Half numerical data instructions, Full numerical data instructions]

PLC memory address		RWr data name		Content																								
RWr	bit	Half numerical data instructions	Full numerical data instructions																									
0	0	Controller Information flag	Return of Occupied number of stations (L)	As same as Single numerical data instructions. Please refer to " <b>10.2 Remote register (RWr and RWw)</b> " for details.																								
	1		Return of Occupied number of stations (H)																									
	2		Sending																									
	3		Sending completed																									
	4		READY																									
	5		ALARM flag																									
	6		Initial																									
	7		Return of the read numerical data																									
	8		Return of parameter rewriting		It is ON when the parameter rewrite flag is enabled. otherwise it is OFF.																							
	C to 9		(No used)		—																							
	D		Data editing error		As same as Single numerical data instructions. Please refer to " <b>10.2 Remote register (RWr and RWw)</b> " for details.																							
	E		Parameter anomaly detection																									
F	The abnormal station																											
1	F to 0	L	Current position																									
2	F to 0	H																										
3	7 to 0	L	Current speed																									
	F to 8	H																										
4	7 to 0	L	Current Force	When the read numerical data is effective, this terminal will output the current force of the electric actuator by 1[%] unit.																								
	F to 8	H																										
5	F to 0	L	Target position	When the read numerical data is effective, this terminal will output the target position of the electric actuator by 0.01[mm] unit																								
6	F to 0	H																										
7	7 to 0	Alarm 1	Alarm 1	When the read numerical data is effective and alarm is generated, alarm code (3 decimal digits) will be output. It is possible to output up to 2 alarms at 2 Stations occupied and output up to 4 alarms at 4 Stations occupied. As for the alarm, generated latest alarm code is output to alarm 1. It is updated every time when the alarm is generated, and alarm code which occurred in the past shifts in order of alarm 1→2→3→4. When the number of generated alarms exceeds the maximum alarm output of each mode, it is deleted from the history in order of the alarm code generated in the past																								
	F to 8	Alarm 2	Alarm 2																									
8	7 to 0	/	Alarm 3	Ex) When the alarm is generated in order of (1)→(5) <table border="1" style="display: inline-table; border-collapse: collapse;"> <tr> <td>Alarm 1 (latest)</td> <td>(1)</td> <td>(2)</td> <td>(3)</td> <td>(4)</td> <td>(5)</td> </tr> <tr> <td>Alarm 2</td> <td>0</td> <td>(1)</td> <td>(2)</td> <td>(3)</td> <td>(4)</td> </tr> <tr> <td>Alarm 3</td> <td>0</td> <td>0</td> <td>(1)</td> <td>(2)</td> <td>(3)</td> </tr> <tr> <td>Alarm 4</td> <td>0</td> <td>0</td> <td>0</td> <td>(1)</td> <td>(2)</td> </tr> </table> (1) to (5) in the list shows generated alarm code Please refer to " <b>16.2 Alarm details</b> " for details of the content of the alarm.	Alarm 1 (latest)	(1)	(2)	(3)	(4)	(5)	Alarm 2	0	(1)	(2)	(3)	(4)	Alarm 3	0	0	(1)	(2)	(3)	Alarm 4	0	0	0	(1)	(2)
	Alarm 1 (latest)		(1)		(2)	(3)	(4)	(5)																				
Alarm 2	0		(1)		(2)	(3)	(4)																					
Alarm 3	0		0		(1)	(2)	(3)																					
Alarm 4	0	0	0	(1)	(2)																							
F to 8	Alarm 4																											
9 to 15	F to 0		Occupation area	—																								

H=Most Significant Byte or upper word  
L=Least Significant Byte or lower word

- Higher level device → Controller [OUT] (Master to Remote)  
[Single numerical data instructions]

PLC memory address		RWw Data name		Content
RWw	bit	Single numerical data instructions		
0	0	Controller control flag	Setting read numerical data	Turn ON to enable reading the numerical data such as the current position or current speed. Turn OFF to disable
	1		(No used)	—
	2		Reset flag	Clear "RWw0, bit5: ALARM flag" by turning this terminal ON from OFF.
	3		Restart flag	Controller's reset is executed again when OFF is changed to ON.
	4	Numerical data input flag	Movement MOD	In the case of Numerical data instructions operation, when each set point is turned on, Numerical data instructions are possible.
	5		Speed *2)	
	6		Position *1)	
	7		Acceleration *2)	
	8		Deceleration *2)	In the case of Single numerical data instructions, it is impossible to input following 11 items (except Movement MOD) at the same time.
	9		Pushing force *2)	
	A		Trigger LV *2)	
	B		Pushing speed *2)	When repeat RWw0, bit5 to F: Setting numerical data A, the alarm (parameter anomaly detection) occurs. Please refer to " <b>17. Alarm Detection for CC-Link Communication</b> " for details.
	C		Moving force *2)	
	D		Area 1 *1)	
	E		Area 2 *1)	
F	In position *1)			
1	0	Start flag		It is a data sending flag at Numerical data instructions operation. When waiting for the sending, this terminal is OFF. And this terminal is ON during sending numerical data to controller.
	7 to 1	(No used)		-
	F to 8	Movement MOD		1 : ABS (Absolute) 2 : INC (incremental)
2	F to 0	L	Numerical data instructions data (2 word data)	Input the numerical value of the item which appoint in Setting numerical data. Please refer to " <b>11.1 Step data</b> " for the input range and the unit of each item. Example) Turn on RWw0,bit6:Position and direct 655.37 [mm] (65537d=10001h) RWw2=0001h RWw3=0001h
3	F to 0	H		
2	7 to 0	L	Numerical data instructions data (1 word data)	Input the numerical value of the item which appoint in Setting numerical data. Please refer to " <b>11.1 Step data</b> " for the input range and the unit of each item. Example) Turn on RWw0,bit5:Speed and direct 300[mm/s] (300d=012Ch) RWw2=012Ch
	F to 8	H		
3	F to 0	(No used)		-

H=Most Significant Byte or upper word

L=Least Significant Byte or lower word

\*1) RWw0, bit4 to F: Setting numerical data in the case of "Position" or "Area 1" or "Area 2"

\*2) RWw0,bit4 to F: Setting numerical data in the case of "Speed", "Acceleration", "Deceleration", "Pushing force", "Trigger LV", "Pushing speed", "Moving force", or "In position"

[Half numerical data instructions, Full numerical data instructions]

PLC memory address		RWw data name		Content			
RWw	bit	Half numerical data instructions	Half numerical data instructions	Setting data range	Unit		
0	0	Controller information flag	Read numerical data flag	Turn ON to enable reading the numerical data such as current position or current speed. Turn OFF to			
	1		Parameter rewrite flag	The data edit function is enabled when this flag is ON. When OFF, operation by numerical instruction is enabled. Before using the numerical instruction			
	2		Reset flag	Turning it OFF then ON will clear the RWr0,bit5: ALARM flag.			
	3		Restart flag	Turn it OFF then ON to re-initialize the controller.			
	4	Numerical data input flag	Movement MOD	It is possible to change the value when each terminal is ON in Numerical data instructions operation function. When the Setting parameter rewriting flag is ON, it becomes invalid. *1) In the half numerical data instruction mode, "Acceleration" and "Pushing force" cannot be input at the same time. *2) In the half numerical data instruction mode, "Deceleration" and "Trigger LV" cannot be input at the same time. When the above-mentioned numerical data input flags (*1, *2) are duplicated, an alarm (Parameter error detected) is generated. Please refer to <b>"17. Alarm Detection for CC-Link Communication"</b> for details. for details.			
	5		Speed				
	6		Position				
	7		Acceleration *1)				
	8		Deceleration *2)				
	9		Pushing force *1)				
	A		Trigger LV *2)				
	B		Pushing speed				
	C		Moving force				
	D		Area 1				
E	Area 2						
F	(No used)	In position					
1	0	Start flag		It is a data sending flag at Numerical data instructions operation function. When waiting for the sending, this terminal is OFF. And this terminal is ON during			
	7 to 1	(No used)		—			
2	F to 8	Numerical data instructions operation	Movement MOD	Input the specified value to the controller. And it is possible to input plural data (speed and target position, etc.) at the same time.  Please refer to <b>"11.1 Step data"</b> for 9 details of each data.  Example) R When turn on the "RWw0,bit6:Position", instruct 655.37 [mm] (65537d=10001h) RWw3=0001h RWw4=0001h	0: Data disabled 1: ABS 2: INC	—	
	7 to 0		L		Speed	Minimum value - "Maximum speed" of basic parameter *3)	1mm/s
3	F to 8		H		Target position	"Stroke (-)" to "Stroke (+)" of the basic	0.01mm
	7 to 0		L		Acceleration (Pushing force)	1 to "Max ACC/DEC" of the basic parameter *3)	1mm/s <sup>2</sup> (1%)
4	F to 8		H		Deceleration (Trigger LV)	1 to "Max ACC / DEC" of the basic parameter	1mm/s <sup>2</sup> (1%)
	7 to 0		L		Pushing speed	*3)	1mm/s (1%)
5	F to 8		H		Acceleration		
	7 to 0		L		Deceleration		
6	F to 8		H		Pushing force		
	7 to 0		L				
7	F to 8		H				
	7 to 0		L				



#### (4) Data editing function

- Controller → Higher level device [IN] (Remote to Master)

PLC memory address		RWr data name		Contents															
RW	bit	Half numerical data instructions	Full numerical																
0	0	Controller information flag	Return of Occupied number of stations (L)	Current occupied number of stations is shown. <table border="1"> <thead> <tr> <th>H</th> <th>L</th> <th>Occupied number of stations</th> </tr> </thead> <tbody> <tr> <td>0</td> <td>0</td> <td>1 Stations occupied</td> </tr> <tr> <td>0</td> <td>1</td> <td>2 Stations occupied</td> </tr> <tr> <td>1</td> <td>0</td> <td>—</td> </tr> <tr> <td>1</td> <td>1</td> <td>4 Stations occupied</td> </tr> </tbody> </table>	H	L	Occupied number of stations	0	0	1 Stations occupied	0	1	2 Stations occupied	1	0	—	1	1	4 Stations occupied
	H		L	Occupied number of stations															
	0		0	1 Stations occupied															
	0		1	2 Stations occupied															
	1		0	—															
	1		1	4 Stations occupied															
	1		Return of Occupied number of stations (H)																
	2		Sending	After turning Start flag on at Step data editing function, this terminal will be ON during sending. And this terminal is OFF when the sending is completed or waiting for the sending instruction.															
	3		Sending completed	When the data sending is completed at Step data editing function, Sending flag will be OFF and this terminal will be ON. Then Start flag turns OFF and this terminal will be OFF.															
	4		READY	It is always ON if the controller has been started normally.															
	5		ALARM flag	An alarm is generated when problems occur with the LECPMJ's internal process or communication with the PLC. OFF during normal condition. ON when an alarm is generated.															
	6		Initial	It is OFF during initial processing. It stays ON once the initial processing is completed.															
	7		Numerical data reading enable/disable flag	It is ON when reading numerical data. Otherwise it is OFF.															
8	Parameter rewriting enable / disable flag	It is ON when the parameter rewrite flag is enabled. When it is disabled, it is OFF.																	
9 to C	(No used)	—																	
D	Data editing error receiving	When the error occurs in the data editing function, this terminal will be ON with RWr0, bit5: ALARM flag. When RWw0, bit2: Reset is turned on, it is cleared.																	
E	Parameter anomaly detection	When a parameter is invalid, this and the RWr0, bit5: ALARM flag are turned ON. It is turned OFF when the RWw0, bit2: Reset flag is turned ON. Please refer to " <b>17. Alarm Detection for CC-Link Communication</b> " for details.																	
F	The abnormal station detection	When an abnormal station is detected, this and the RWr0, bit5: ALARM flag are turned ON. It is turned OFF when the RWw0, bit2: Reset flag is ON. Please refer to " <b>17. Alarm Detection for CC-Link Communication</b> " for details.																	



1	F to 0	L	Current position		The current position of the electric actuator is shown in multiples of 0.01 mm when numerical data reading is enabled. Example) 800.00mm (80000d=13880h) is output: RWr1=3880h RWr2=0001h	
2	F to 0	H				
3	7 to 0	L	Return of Data editing	Sub Function	Current speed	<ul style="list-style-type: none"> <li>• Half numerical data instructions The executed instruction code is output. Please refer to <b>"9.5 Data editing function"</b> for details of the instruction code. The value of 80h that is the OR (logical add) is output to Sub Function which set in RWr1. *3)</li> <li>• Full numerical data instructions The current speed of the electric actuator is shown in multiples of 1 mm/s when numerical data reading is enabled Example) 300 mm/s (300d=012Ch) is output RWr3=012Ch</li> </ul>
	F to 8	H				
4	7 to 0	L		Address	Current Force	<ul style="list-style-type: none"> <li>• Half numerical data instructions The start address of the executed instruction code is output. Please refer to <b>"9.5 Data editing function"</b> for details of the instruction code 00h is output in abnormal conditions.*3)</li> <li>• Full numerical data instructions The current pushing force of the electric actuator is shown in multiples of 1% when numerical data reading is enabled.</li> </ul>
	F to 8	H				

H=Most Significant Byte or upper word

L=Least Significant Byte or lower word

●To upper level device from the controller [IN] (to base module from the remote module) -  
continued

PLC memory		RWw data name		Content																									
RWr	bit	Half numerical data instructions	Full numerical data																										
5	F to 0 L	Return of Data editing	Address (always 0)	<ul style="list-style-type: none"> <li>Half numerical data instructions 0 is always output.</li> <li>Full numerical data instructions The target position of the electric actuator is shown in multiples of 0.01 mm when numerical data reading is enabled.</li> </ul>																									
6	F to 0 H		DATA(H)	<ul style="list-style-type: none"> <li>Half numerical data instructions Data that corresponds to the executed instruction code is output. An error code is output when there is an abnormality.</li> <li>Full numerical data instructions The target position of the electric actuator is shown in multiples of 0.01 mm when numerical data reading is enabled.</li> </ul>																									
7	7 to 0		DATA(L)	Alarm 1	<ul style="list-style-type: none"> <li>Half numerical data instructions Data that corresponds to the executed instruction code is output. 00h is output when there is an abnormality. *3)</li> <li>Full numerical data instructions Alarm code shown as a 3 digit decimal number when numerical data reading is enabled and an alarm is generated. In the half numerical data instruction mode, up to two alarms can be output. In the full numerical data instruction mode, up to four alarms can be output.</li> </ul> <p>The latest alarm code generated will be output to alarm 1. Alarm is updated by another alarm. The code of the previous alarms generated will be shifted to alarm1→2→3→4.</p> <p>When the number of alarms generated exceeds the maximum alarm output for each mode, the oldest alarm code is deleted from the record. Example) Alarms were generated in order of (1) → (5)</p> <table border="1" style="margin-left: 20px;"> <tr> <td>Alarm 1 (The latest)</td> <td>(1)</td> <td>(2)</td> <td>(3)</td> <td>(4)</td> <td>(5)</td> </tr> <tr> <td>Alarm 2</td> <td>0</td> <td>(1)</td> <td>(2)</td> <td>(3)</td> <td>(4)</td> </tr> <tr> <td>Alarm 3</td> <td>0</td> <td>0</td> <td>(1)</td> <td>(2)</td> <td>(3)</td> </tr> <tr> <td>Alarm 4</td> <td>0</td> <td>0</td> <td>0</td> <td>(1)</td> <td>(2)</td> </tr> </table> <p>(1) to (5) in the table indicate the codes for the generated alarms. Please refer to "16.2 Alarm details" for the alarm details.</p>	Alarm 1 (The latest)	(1)	(2)	(3)	(4)	(5)	Alarm 2	0	(1)	(2)	(3)	(4)	Alarm 3	0	0	(1)	(2)	(3)	Alarm 4	0	0	0	(1)	(2)
	Alarm 1 (The latest)			(1)		(2)	(3)	(4)	(5)																				
Alarm 2	0		(1)	(2)		(3)	(4)																						
Alarm 3	0		0	(1)		(2)	(3)																						
Alarm 4	0		0	0	(1)	(2)																							
F to 8	Alarm 2																												
8	7 to 0		Alarm 3																										
	F to 8		Alarm 4																										
9	F to 0			Sub Function	The executed instruction code is output. Please refer to "9.5 Data editing function" for details of the instruction code. The value of 80h that is the OR (logical add) is output to Sub Function which set in RWw1. *3)																								
10	F to 0		Address	The start address of the executed instruction code is output. Please refer to "9.5 Data editing function" for details of the instruction code. 00h is output in abnormal conditions. *3)																									
11	F to 0		Address (always 0)	0 is always output																									

12	F to 0		DATA(H)	The data of the executed instruction code is output. Error code is output in abnormal conditions. *3)
13	F to 0		DATA(L)	The data of the executed instruction code is output. 00h is output in abnormal conditions. *3)
14	F to 0		Occupation area	—
15	F to 0			

H=Most Significant Byte or upper word

L=Least Significant Byte or lower word

\*3) When the error occurred in the data edit function by the specified address which is out of the range etc., the value of 80h that is the OR (logical add) is output to Sub Function which set in Rww1 is returned to Sub Function RWr3 (RWr9 at Full numerical data instructions), and the received error code is returned to DATA (H) [RWr6] (RWrC at Full numerical data instructions). And RWr4:Address and RWr7: DATA (L) ( RWrA and RWrD at Full numerical data instructions) will be 00h. Error code is shown below.

Error code	Name	Content
2	Out of address range	1) The setting of the reading/writing start number is out of address range 2) Writing in a number (address) which is not permitted
3	Out of access point number range	The setting of the reading/writing final number is out of the range

●Higher level device → Controller [OUT] (Master to Remote)

PLC memory address		Rww data name		Content
Rww	bit	Half numerical data instructions	Full numerical data instructions	
0	0	Controller control flag	Setting read numerical data	Turn ON to enable reading the numerical data such as current position or current speed. Turn OFF to disable reading.
	1		Setting parameter rewriting	When this flag is ON, the data edit function is enabled. When OFF, operation by numerical instruction is enabled. Before using the numerical instruction operation, be sure to turn this flag OFF.
	2		Reset flag	Turning it OFF then ON will clear the RWr0, bit5: ALARM flag.
	3		Restart flag	Turn it OFF then ON to re-initialize the controller.
	4		Start flag	Data transmission flag during data edit operations. It is OFF while waiting to transmit. Turn it ON when transmitting parameters to the controller.
	5 to F		(No used)	—
1	F to 0	Send of Data	Sub Function	Input the instruction code to be executed. Please refer to <b>"9.5 Data edit function"</b> for details.
2	F to 0		Address	Input the start address of the instruction code to be executed. Please refer to <b>"9.5 Data edit function"</b> for details.
3	F to 0		Address(always 0)	0 is always output.
4	F to 0		DATA(H)	Input data for some instruction codes. Please refer to <b>"9.5 Data edit function"</b> for details.
5	F to 0		DATA(L)	
6	F to 0		Occupation area	
7	F to 0	Occupation area		—
8 to 15	F to 0	Occupation area		—

H=Most Significant Byte or upper word

L=Least Significant Byte or lower word

## 11. Settings and Data Entry

In order to move the electric actuator to a specific position, it is necessary to setup the patterns of operations with a PC (with the controller setting software) or the teaching box or record data. This setup data input by the software or teaching box will be recorded in the memory of the controller.

For the controller setting software and the teaching box, there are two available modes. You can select the appropriate one depending on the operation.

- Easy mode

In Easy mode, the actuator can be started by entering only a limited number of settings with the controller setting software and the teaching box.

- \* The combination of settings you need to set up will change depending on the type of actuator. (A combination of data can be selected).

- Normal mode

In Normal mode, a more detailed setup can be made (conditions for actuator and controller, etc.) than in Easy mode.

Three kinds of setting data can be changed in this mode; "Step data", "Basic parameter" and "Return to origin parameter".

### 11.1 Step Data

A "step data" is the setting data mainly describing the movement of the actuator. Total 64 step data (12 attributes per step) can be handled with this controller. Each step data will become effective as soon as it is recorded into the controller.

E.g.) Step data on the PC (controller setting software) screen [Normal mode]

No.	Movement mode	Speed [mm/s]	Position [mm]	Acceleration [mm/s <sup>2</sup> ]	Deceleration [mm/s <sup>2</sup> ]	Pushing force [%]	Trigger LV [%]	Pushing speed [mm/s]	Moving force [%]	AREA 1 [mm]	AREA 2 [mm]	In position [mm]
0	ABS	100	20.00	1000	1000	0	0	0	100	18.00	22.50	0.5
1	ABS	50	10.00	1000	1000	70	60	5	100	6.0	12.0	1.5
⋮	⋮	⋮	⋮	⋮	⋮	⋮	⋮	⋮	⋮	⋮	⋮	⋮
63	ABS	20	5.00	500	500	0	0	0	100	3.0	8.0	1.2

### Caution

Writing of the step data should be performed while the electric actuator is stopped.

## Step Data details

Description		Range	Explanation																
Controller setting software	Teaching box (TB)																		
No.	Step No.	0 to 63	Number of the step data.																
Movement mode	Movement mode	3 types (Refer to the table on the right)	Specifies the co-ordinate system for the target position.																
			<table border="1"> <thead> <tr> <th>Software</th> <th>TB</th> <th>PLC</th> <th>Details</th> </tr> </thead> <tbody> <tr> <td>Blank</td> <td>Disable</td> <td>0</td> <td>The step data is ineffective.</td> </tr> <tr> <td>Absolute</td> <td>Absolute</td> <td>1</td> <td>The target position will be defined in relation to the absolute origin point.</td> </tr> <tr> <td>Relative</td> <td>Relative</td> <td>2</td> <td>The target position will be defined relative to the current position.</td> </tr> </tbody> </table>	Software	TB	PLC	Details	Blank	Disable	0	The step data is ineffective.	Absolute	Absolute	1	The target position will be defined in relation to the absolute origin point.	Relative	Relative	2	The target position will be defined relative to the current position.
			Software	TB	PLC	Details													
			Blank	Disable	0	The step data is ineffective.													
Absolute	Absolute	1	The target position will be defined in relation to the absolute origin point.																
Relative	Relative	2	The target position will be defined relative to the current position.																
Speed	Speed	Minimum value to "Max speed" of the basic parameter *1)	The speed to move to the target position. (Unit: mm/s)																
Position	Position	Basic parameter "Stroke (-)" - "Stroke (+)"	The target position (unit: mm)																
Acceleration	Acceleration	1 to Basic parameters "Maximum acceleration/ deceleration speed"	Sets the acceleration to reach to travel speed. (Unit: mm/s <sup>2</sup> )																
Deceleration	Deceleration	1 to Basic parameters "Maximum acceleration/ deceleration speed"	Sets the deceleration from travel speed to stop. (Unit: mm/s <sup>2</sup> )																
Pushing force	Pushing force	0 or Minimum value to "Max force" of the basic parameter *1)	The setting to define the pushing operation or the positioning operation. For the positioning operation, the value specifies the force as a percentage of the maximum force (Unit: %). *The maximum force depends on the actuator. Please refer to the manual and the rated force of the actuator.																
			<table border="1"> <thead> <tr> <th>Value</th> <th>Movement mode</th> <th>Details</th> </tr> </thead> <tbody> <tr> <td>0</td> <td>Positioning operation</td> <td>The actuator moves to the position specified in the "Position".</td> </tr> <tr> <td>1 to 100</td> <td>Pushing operation</td> <td>The actuator moves to the position specified in the "Position" and then, performs a pushing action with a force not more than the set force.</td> </tr> </tbody> </table>	Value	Movement mode	Details	0	Positioning operation	The actuator moves to the position specified in the "Position".	1 to 100	Pushing operation	The actuator moves to the position specified in the "Position" and then, performs a pushing action with a force not more than the set force.							
			Value	Movement mode	Details														
0	Positioning operation	The actuator moves to the position specified in the "Position".																	
1 to 100	Pushing operation	The actuator moves to the position specified in the "Position" and then, performs a pushing action with a force not more than the set force.																	
Trigger LV	Trigger LV	Minimum value to "Max force" of the basic parameter *1)	<ul style="list-style-type: none"> <li>■ Effective only for the pushing operation (the value for the "Pushing force" is between 1 to 100). "Trigger LV" is the setting to define the conditions where "INP" will turn ON. When the actuator generates a force greater than this value, "INP" will turn ON. This parameter is set according to the value of the pushing force or lower. (Unit: %)</li> <li>■ For the positioning operation, this value is ignored.</li> </ul>																

Pushing speed	Pushing speed	Minimum value to "Max force" of the basic parameter *1)	<p>■Effective only for the pushing operation (when the value for the "Pushing force" is from 1 to 100). This defines the movement speed during the pushing operation. If this Speed is too high, it may cause damage to the actuator or work piece due to impacts. Therefore, enter a value within the range appropriate for the actuator. (Unit: mm/s) Please refer to the actuator manual for the appropriate range of the speed.</p> <p>■For the positioning operation, this value is ignored.</p>						
Moving force	Moving force	*1)	<p>The setting to define the maximum torque during the positioning operation. Enter a value within the range appropriate for the actuator. (Unit: %) Please refer to the actuator manual for the appropriate range of the speed.</p>						
AREA 1	AREA 1	"Stroke (-)" to "Area2" of step data	<p>The setting to define the conditions where "AREA" will turn ON. (Unit: mm) If the current position is within the range between Area1 and Area2, the "AREA" signal will turn ON.</p> <p>* If Area1 &gt; Area2, the alarm "Step Data ALM1" will be activated. (However, no alarm is generated if "Area1" = "Area2" = 0, the "AREA" signal will be OFF).</p>						
AREA 2	AREA 2	"Area1" of step data to "Stroke (+)" of the basic parameter							
In position	In position	*1)	<p>The functions of this will be different between the pushing operation and the positioning operation.</p> <p>* Positioning operation: Positioning range (Unit: mm)</p> <p>* Pushing operation: Pushing distance (Unit: mm)</p> <table border="1"> <thead> <tr> <th>Movement mode</th> <th>Details</th> </tr> </thead> <tbody> <tr> <td>Positioning operation</td> <td> <p>This is the setting to define the conditions where "INP" will turn ON. When the actuator enters within this range from the target position, "INP" will turn ON. (It is not necessary to change this from the initial value). If it is required to receive a signal before the actuator completes the positioning operation, this value should be larger.</p> <p>* "INP" will turn ON.</p> <p>Target position - in position ≤ actuator position ≤ target position + in position</p> </td> </tr> <tr> <td>Pushing operation</td> <td> <p>This is the setting to define the distance pushed by the actuator during the pushing operation. When the actuator has exceeded this distance, the pushing operation will end. In this case, "INP" will not turn ON.</p> </td> </tr> </tbody> </table>	Movement mode	Details	Positioning operation	<p>This is the setting to define the conditions where "INP" will turn ON. When the actuator enters within this range from the target position, "INP" will turn ON. (It is not necessary to change this from the initial value). If it is required to receive a signal before the actuator completes the positioning operation, this value should be larger.</p> <p>* "INP" will turn ON.</p> <p>Target position - in position ≤ actuator position ≤ target position + in position</p>	Pushing operation	<p>This is the setting to define the distance pushed by the actuator during the pushing operation. When the actuator has exceeded this distance, the pushing operation will end. In this case, "INP" will not turn ON.</p>
Movement mode	Details								
Positioning operation	<p>This is the setting to define the conditions where "INP" will turn ON. When the actuator enters within this range from the target position, "INP" will turn ON. (It is not necessary to change this from the initial value). If it is required to receive a signal before the actuator completes the positioning operation, this value should be larger.</p> <p>* "INP" will turn ON.</p> <p>Target position - in position ≤ actuator position ≤ target position + in position</p>								
Pushing operation	<p>This is the setting to define the distance pushed by the actuator during the pushing operation. When the actuator has exceeded this distance, the pushing operation will end. In this case, "INP" will not turn ON.</p>								

\*1 The range varies depending on the electric actuator. Please refer to the manual of the electric actuator for more details.

## 11.2 Basic parameters

The "Basic parameter" is the data to define the operating conditions of the controller, conditions of the actuator, etc.

### Caution

Writing of the parameter should be performed while the electric actuator is stopped.

Activation: "XX" = Become effective just after recorded into the controller  
 "X" = Become effective after restarting the controller  
 "—" = The parameter cannot be changed (fixed value)

#### Basic parameters.

Parameter name	Input range	Details	Acti vation
Controller ID	1 to 32	Identification number (axis) parameters of serial communications (communication with PC, teaching box) are set.	X
I/O pattern	Fixed value	This is a fixed value for the controller. Do not change the setting. (Default value is "1")	—
ACC/ DEC pattern	Fixed value	This is a fixed value for the controller. Do not change the setting. (The default value varies depending on the electric actuator)	—
S-motion rate	Fixed value	This is a fixed value for the controller. Do not change the setting. (The default value varies depending on the electric actuator)	—
Stroke (+)	*1)	This defines the positive (+) side limit of the position. (Unit: mm) Any value greater than the [stroke (+)] value cannot be entered in the "Position" field data of step parameter setup.	XX
Stroke (-)	*1)	This defines the positive (-) side limit of the position. (Unit: mm) Any value greater than the [stroke (+)] value cannot be entered in the "Position" field data of step parameter setup.	XX
Max speed	*1)	This defines the maximum limit of the speed. (Unit: mm/s) Any value greater than the [stroke (+)] value cannot be entered in the "Position" field data of step parameter setup.	XX
Max ACC/DEC	*1)	This defines the maximum settable acceleration. (Unit: mm/s <sup>2</sup> ) Any value greater than the [Max ACC/DEC] value cannot be entered in the "Accel" field data of step parameter setup.	XX
Def In position	*1)	This defines the range to activate the INP when the actuator is within it after the return to origin operation.(Unit: mm)	XX

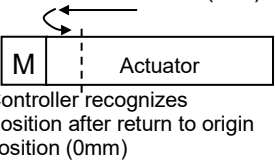
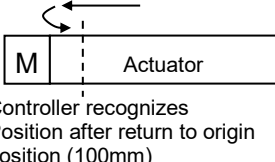
ORIG offset	*1)	<p>This defines the position of the actuator after the return to origin operation.(Unit: mm)</p> <p>■ The ORIG offset is 0 (mm).</p>  <p>Controller recognizes Position after return to origin position (0mm)</p> <p>■ The ORIG offset is 100 (mm)</p>  <p>Controller recognizes Position after return to origin position (100mm)</p> <div style="border: 1px solid black; padding: 5px; text-align: center;"> <p><b>⚠ Caution</b></p> <p>If the value for the “ORIG offset” is changed, the “Stroke (+)” and “Stroke (-)” of the basic parameters should be checked. “ORIG offset” becomes valid after the return to origin operation, make sure that return to origin operation is performed after any changes.</p> </div>	XX
Max force	*1)	The maximum force for the pushing operation (Unit: %).	XX
Para protect	1 to 2	<p>Sets the range in which the parameter and step data can be changed.</p> <ol style="list-style-type: none"> <li>1. Basic parameter + Step data (Basic parameter + Return to origin parameter + Step data)</li> <li>2. Basic parameter (Basic parameter + Return to origin parameter)</li> </ol>	XX
Enable SW	1 to 2	<p>This defines the status of the Enable switch of the teaching box.</p> <ol style="list-style-type: none"> <li>1: Enabled</li> <li>2: Disable</li> </ol>	XX
Unit name	Fixed value	<p>Indication of actuator type compatible with the controller.</p> <p>Do not change the setting.</p>	-



W-AREA1	“Stroke (-)” to “Stroke (+)” of the basic parameter	This is the setting to define the conditions where the WAREA will be turned ON. [Unit: mm] If the current position is within the range between the W area end 1 and W area end 2, the WAREA will be turned ON. * If W area output end 1 >W area output end 2, the alarm “Parameter ALM” will be activated. However no alarm is generated if W area end 1 = W area end 2 = 0, the WAREA will be turned OFF	XX									
W-AREA2	“Stroke (-)” to “Stroke (+)” of the basic parameter		XX									
ORG Correct	Fixed value	This is a fixed value for the controller. Do not change the setting. (Default value is “0”)	—									
Sensor type	Fixed value	This is a fixed value for the controller. Do not change the setting. (Default value is “2”)	—									
Option 1 (Occupied number of stations of CC-Link)	1,2,4	Set the operation mode for the controller (number of occupied stations). <table border="1" style="width: 100%; border-collapse: collapse;"> <thead> <tr> <th style="width: 15%;">Parameter</th> <th style="width: 85%;">Operation mode (number of occupied stations)</th> </tr> </thead> <tbody> <tr> <td style="text-align: center;">1</td> <td>Single numerical data instruction mode (1 stations is occupied)</td> </tr> <tr> <td style="text-align: center;">2</td> <td>Half numerical data instruction mode (2 stations are occupied)</td> </tr> <tr> <td style="text-align: center;">4</td> <td>Full numerical data instruction mode (4 stations are occupied)</td> </tr> </tbody> </table>	Parameter	Operation mode (number of occupied stations)	1	Single numerical data instruction mode (1 stations is occupied)	2	Half numerical data instruction mode (2 stations are occupied)	4	Full numerical data instruction mode (4 stations are occupied)	X	
Parameter	Operation mode (number of occupied stations)											
1	Single numerical data instruction mode (1 stations is occupied)											
2	Half numerical data instruction mode (2 stations are occupied)											
4	Full numerical data instruction mode (4 stations are occupied)											
Undefined parameter No.11 (Operation setting at CC-Link communication error)	0, 10	Set the operating method of CC-Link communication abnormality (time-out, malfunction, and CRC error). <table border="1" style="width: 100%; border-collapse: collapse;"> <thead> <tr> <th style="width: 15%;">Parameter</th> <th style="width: 15%;">Output the data to control unit</th> <th style="width: 70%;">Details</th> </tr> </thead> <tbody> <tr> <td style="text-align: center;">0</td> <td>Hold (Hold the operating state)</td> <td>Even if communication abnormality occurs in CC-Link, the alarm does not occur. The control unit continues operation and executes it.</td> </tr> <tr> <td style="text-align: center;">10</td> <td>Alarm stop</td> <td>When the communication abnormality occurs in CC-Link, the control unit will be stop state by the alarm and outputs “Communication alarm 150”.</td> </tr> </tbody> </table>	Parameter	Output the data to control unit	Details	0	Hold (Hold the operating state)	Even if communication abnormality occurs in CC-Link, the alarm does not occur. The control unit continues operation and executes it.	10	Alarm stop	When the communication abnormality occurs in CC-Link, the control unit will be stop state by the alarm and outputs “Communication alarm 150”.	X
Parameter	Output the data to control unit	Details										
0	Hold (Hold the operating state)	Even if communication abnormality occurs in CC-Link, the alarm does not occur. The control unit continues operation and executes it.										
10	Alarm stop	When the communication abnormality occurs in CC-Link, the control unit will be stop state by the alarm and outputs “Communication alarm 150”.										
Undefined parameter No.12	Fixed value	This is a fixed value for the controller. Do not change the setting. (Default value is “0”)	—									

- \*1) The actuator model determines the available input values. Refer to the operation manual of the actuator for details.
- \*2) It is recommended to set the “maximum speed” for the electric actuator operation. Control is restricted so that the set value is not exceeded. The response will be slower because of this.
- \*3) For the basic parameter "Parameter protection" to "3: Common + Extend + Step", set it according to the following procedures.
1. Start controller-setting software (JXC-W2) in the Normal mode.
  2. Select "HELP" - "Password" from the menu and input "password" in the password input screen.
  3. Change the basic parameter "Parameter protection" to "3: Common + Extend + Step" in the Parameter window.
  4. Click "Download" to transmit the change. The text colour of the changed parameter will change from blue to black.
  5. After completing the setting, turn the JXCM1 OFF then ON to make the change effective.

### 11.3 Return to origin parameter

The “Return to origin parameter” is the setting data for the return to origin operation.

Activation: “XX” = Become effective just after recorded into the controller  
 “X” = Become effective after restarting the controller  
 “—” = The parameter cannot be changed (fixed value)

#### Details of Return to origin parameter

Parameter name	Range	Description	Activation
ORIG direction	1 to 2	Sets the direction of return to origin operation. Note1) 1. CW 2. CCW	X
Return to origin mode	1 to 2	The setting for the return to origin operation. 1: Pushing origin operation [Stop] 2: Limit switch origin [SW]	XX
ORIG limit	Note2)	A pushing force level at which to set the origin.	XX
ORIG time	Fixed value	This is a fixed value for the controller. (Do not change the setting)	—
ORIG speed	Note2)	The allowable speed to move to origin.	XX
ORIG ACC/ DEC	Note2)	The acceleration and deceleration during return to origin operation.	XX
Creep speed	Fixed value	This is a fixed value for the controller. (Do not change the setting)	—
ORIG sensor	0 to 2	The setting for the ORIG sensor. 0. The origin sensor is not effective. [Disable] 1. The origin sensor is N.O type. [N.O]. 2. The origin sensor is N.C type. [N.C].	XX
ORIG SW DIR	Fixed value	This is a fixed value for the controller. (Default value is “0”)	—
Undefined parameter No.21	Fixed value	This is a fixed value for the controller. (Default value is “0”)	—

Note1) When power is applied again after changing Return to origin parameter “Return to Origin Direction”, the SETON output is turned OFF.  
 Perform return to origin operation again.

Note2) The actuator model determines the available input values. Refer to the operation manual of the actuator for details.

## 11.4 Operation parameters

This is data to set the JOG operation of the controller.

To change operation parameters, set the basic parameter "Parameter protection" to "3: Common + Extend + Step".

### Details of the operation parameters

Activation: "XX" = Become effective just after recorded into the controller,

"X" = Become effective after restarting the controller,

"-" = The parameter cannot be changed (fixed value).

Controller setting software	Range	Description	Acti- vation
JOG speed	*1)	Defines the JOG operation speed. (Unit: 1 mm/s)	XX
JOG acceleration	1 to "Max ACC/DEC" of the basic parameter	Defines the JOG operation acceleration. (Unit: 1 mm/s <sup>2</sup> )	XX
JOG deceleration	1 to "Max ACC/DEC" of the basic parameter	Defines the JOG operation deceleration. (Unit: 1 mm/s <sup>2</sup> )	XX
JOG thrust	*1)	Defines the torque limit during JOG operation. (Unit: 1%)	XX
Fixed distance	0.01 to Full stroke *1)	Defines the Inching distance. (Unit: 0.01 mm)	XX

\*1) This depends on the electric actuator. Set a value that is equal to or smaller than the catalogue recommended value for positioning operation or pushing operation, according to the operating manual for each electric actuator.

## 12. Operations

### 12.1 Return to origin position

Return to origin operation should be performed first in the following cases.:

- (1) When power is applied for the first time.
- (2) When the actuator or motor is replaced.
- (3) When alarm "Group E" is cleared by applying the power again.

For (1) and (2), Alarm No.10-153 "Absolute encoder ID Alarm error" is generated after the power is applied, so perform the return to origin operation after resetting the alarm.

#### Return to origin operation

The actuator moves in the return to origin direction (\* this direction is dependent on the actuator) from the initial position at the moment of power ON. Refer to (1) in the figure below.

When the actuator reaches the end of travel limit it pauses for a short time. The controller recognizes the position as the end of travel limit of the actuator. Then, the actuator moves at a low speed in the direction opposite to the return to origin direction: Refer to (2) in the figure below.

The position after the travel becomes the origin.

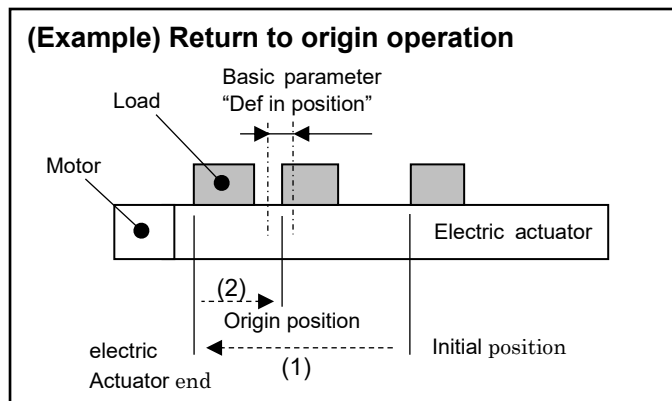
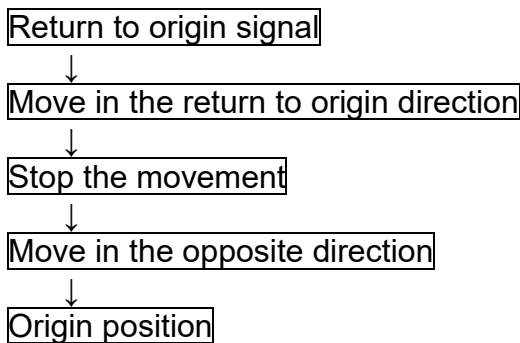

### Caution

This direction is dependent on the electric actuator.

### 12.2 Positioning Operation

Step data "Pushing force" is set to 0.

The actuator moves to the target position specified by the step data "Position".

#### •(E.g.) Positioning Operation

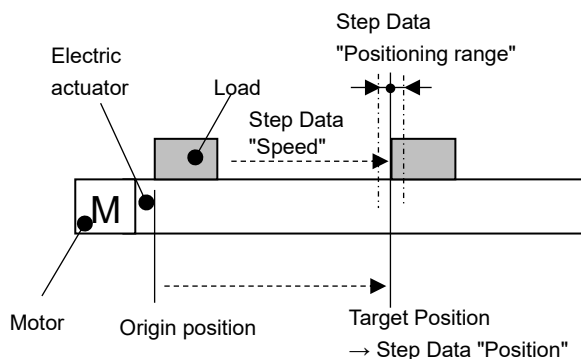

#### •(E.g.) Positioning operation [Speed/Position]

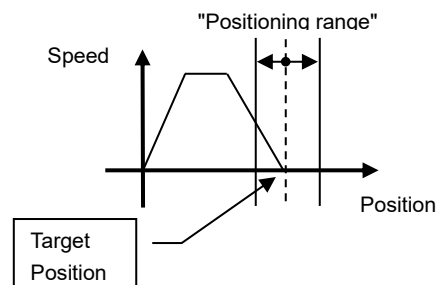

## 12.3 Pushing Operation

The pushing operation is active when the value of the "Pushing F%" in the Step data is set to "1" or more. Similar to the positioning operation, the actuator moves according to the settings of "Position" and "Speed" in the step data and then, when it reaches the target position, it starts the pushing process.

The actuator pushes the load with a force no more than the maximum force set in the "Pushing force" of the step data.

### (1) Pushing operation is successfully performed.

During the pushing operation, if the pushing force is kept higher than the value specified by "Trigger LV" of the step data for a certain time, "INP" will turn ON. Even after the completion of the pushing operation, the actuator will keep generating the force set in the step data.

#### •(E.g.) Pushing operation

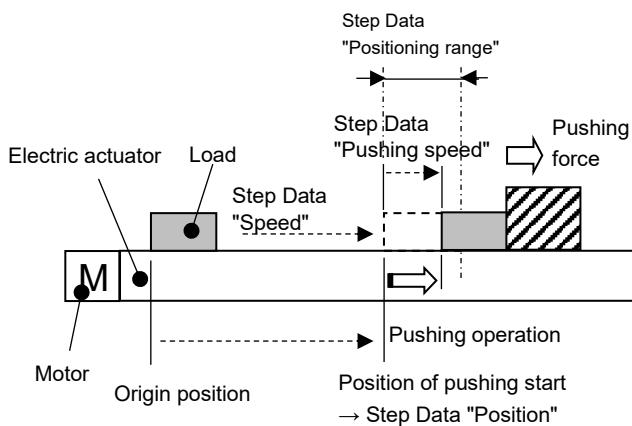

#### •(E.g.) Pushing operation [Speed/Position]

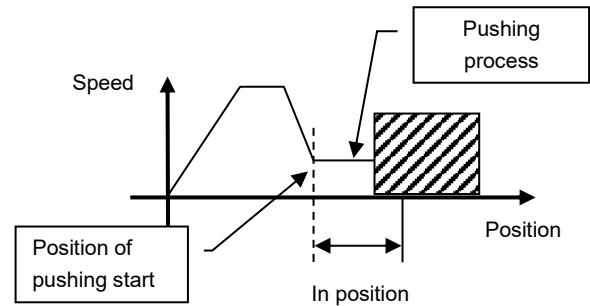

### (2) Pushing operation fails (empty pushing).

If the pushing process is not completed even after the actuator runs over the range specified in the step data from the target position (the starting point of the pushing process), the operation will be completed. In this case, "INP" will turn OFF.

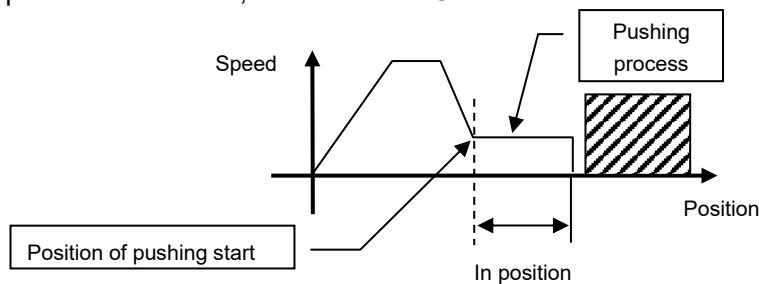

### (3) Movement of the workpiece after the completion of the pushing process

[1] The workpiece moves in the pushing direction.

After completion of the pushing operation, if the reaction force from the workpiece becomes smaller, the actuator may move with a force smaller than that specified in the "Trigger LV" of the step data.

In this case, "INP" will turn OFF and the actuator moves within the positioning range according to the balance of the force.

If the pushing force is kept higher than the value specified by "Trigger LV" of the step data for a certain time again, "INP" will turn ON.

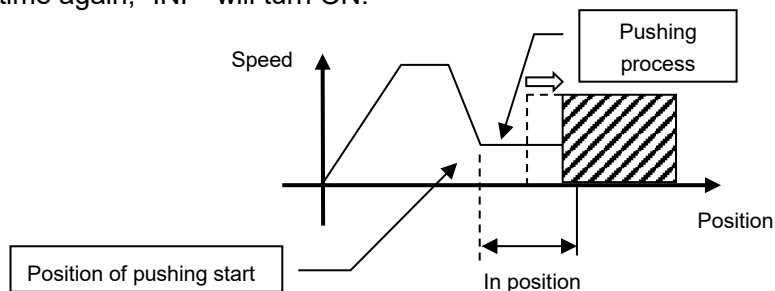

- [2] Movement of the workpiece in the direction opposite to the pushing direction (The actuator is pushed back since the reaction force from the workpiece is too large.)  
 After completion of the pushing operation, if the reaction force from the workpiece becomes larger, the actuator may be pushed back. In this case, while “INP” remains ON, the actuator will be pushed back to the point where the reaction force and the actuator pushing force are balanced (pushed back toward the target position).  
 If the actuator is pushed back over the target position, the alarm (ORIG ALM) will be activated.

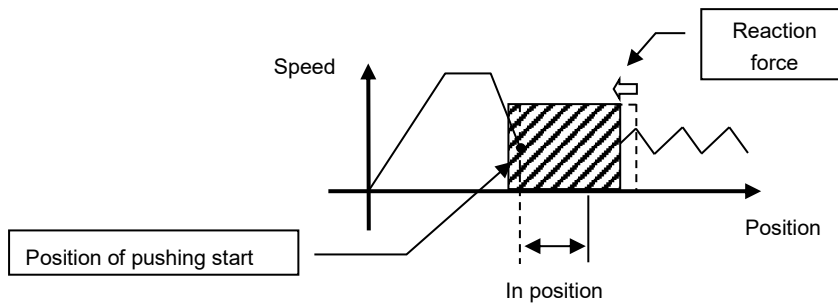

## 12.4 Controller input signal response time

The controller input signal response delay include the following factors.

- (1) Controller input signal scan delay
- (2) Delay due to input signal analysis
- (3) Delay of command analysis

Set the time more than twice the communication cycle time for the interval between the signals, when the signals are continuously input, as PLC processing delays and controller scanning delays can occur.

## 12.5 Methods of interrupting operation

here are 3 methods of interrupting operation and stopping the actuator during positioning operation and pushing operation, as shown below. The state after the interruption is different, therefore use the method appropriate to the application.

- Stopping by “EMG” signal

If the “EMG” signal is turned OFF during operation, after the actuator decelerates and stops, the servo will turn OFF, and the stopped position is not held.  
 (For an actuator with lock, it will be held by the lock function).

- Stopping by “RESET” signal

If the “RESET” signal is turned ON during operation, after the actuator decelerates and stops, the stopped position is held.  
 (The servo does not turn OFF).

- Stopped by “HOLD” signal

The actuator decelerates to stop when the “HOLD” signal is ON during operation.  
 (The servo does not turn OFF).

### ⚠ Caution

If instructed to stop by the “EMG” or “RESET” signal, all “OUT” signals will turn OFF.  
 The RESET signal input during HOLD is valid.

# 13. Operation Examples

## 13.1 Positioning Operation

E.g.) Move an actuator from the origin to 100mm point at 50mm/s. (Step No.1 instruction)

Next, move the actuator from the 50mm point to 100mm point by moving it 5 times continuously, 10mm at a time, at a speed of 50mm/s. (Step No. 2)

### ■ [Normal mode] Step data example

No	Movement mode	Speed [mm/s]	Position [mm]	Acceleration [mm/s <sup>2</sup> ]	Deceleration [mm/s <sup>2</sup> ]	Pushing force [%]	Trigger LV [%]	Pushing speed [mm/s]	Moving force [%]	AREA 1 [mm]	AREA 2 [mm]	In position [mm]
0	-	-	-	-	-	-	-	-	-	-	-	-
1	ABS	100	50.00	1000	1000	0	0	0	100	0	0	0.1
2	INC	50	10.00	1000	1000	0	0	0	100	0	0	0.1

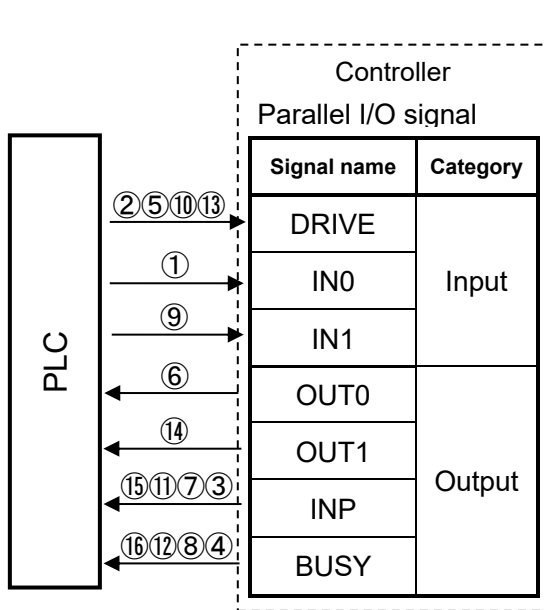

(E.g.) Operation

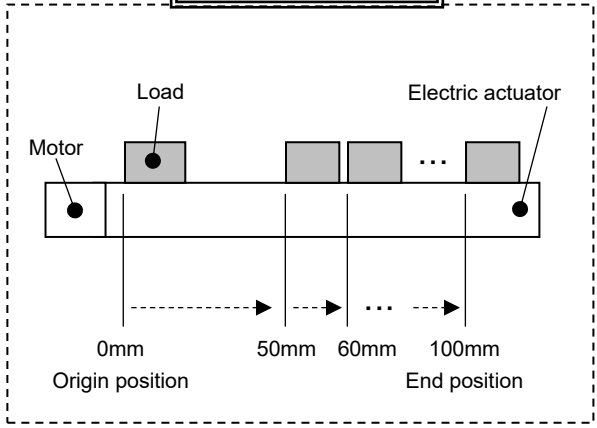

(E.g.) Flow chart

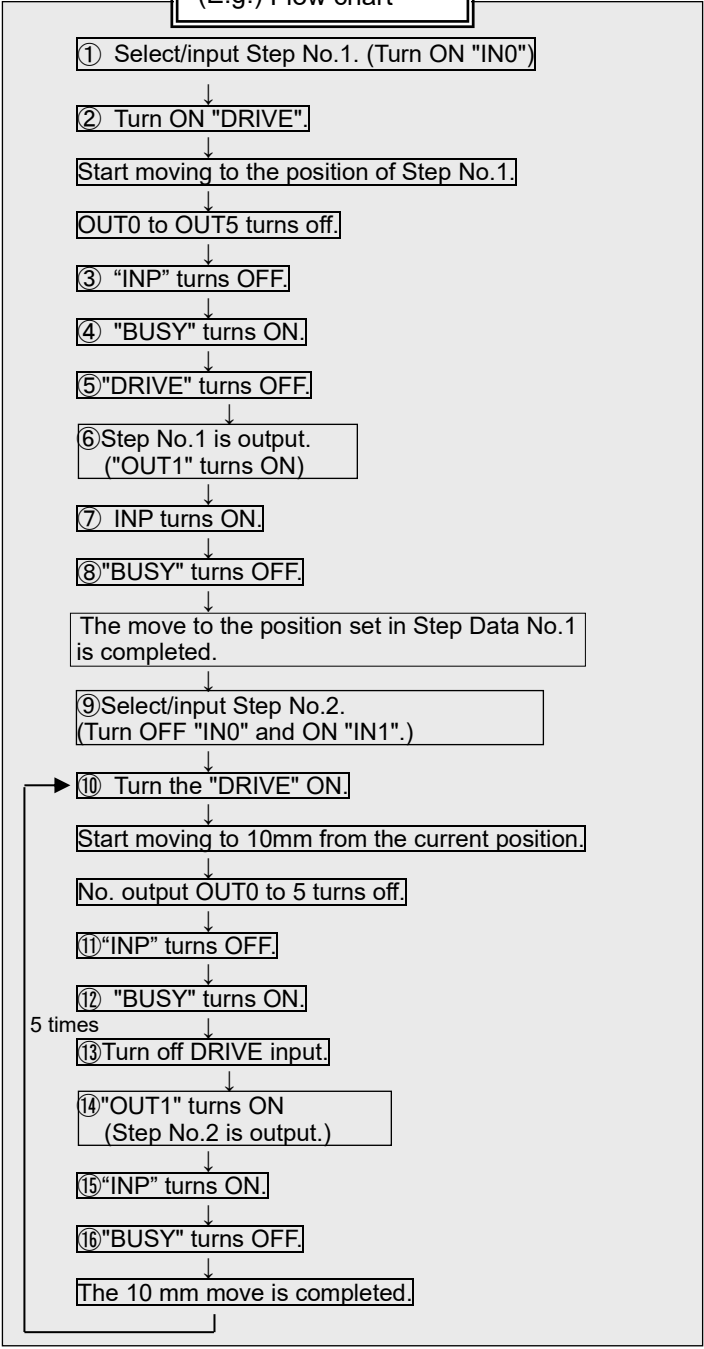

## 13.2 Pushing Operation

Eg.) Move the actuator from the origin to a point 100 mm away at 100 mm/s. (Step Data No.1 is used for this operation).

From the 100 mm point, the actuator must start a pushing operation of 10 mm/s speed and 50% or less force.

(the pushing distance is up to 5 mm).

Then, the actuator should move from the position where the pushing operation was completed (where "INP" turned ON) to a point 50 mm away at 50 mm/s.

(Step Data No.2 is used for this operation).

### ■ [Normal mode] Step data example

No	Movement mode	Speed [mm/s]	Position [mm]	Acceleration [mm/s <sup>2</sup> ]	Deceleration [mm/s <sup>2</sup> ]	Pushing force [%]	Trigger LV [%]	Pushing speed [mm/s]	Moving force [%]	AREA 1 [mm]	AREA 2 [mm]	In position [mm]
0	-	-	-	-	-	-	-	-	-	-	-	-
1	ABS	100	100.00	1000	1000	50	40	10	100	0	0	5
2	ABS	50	50.00	1000	1000	0	0	0	100	0	0	0.1

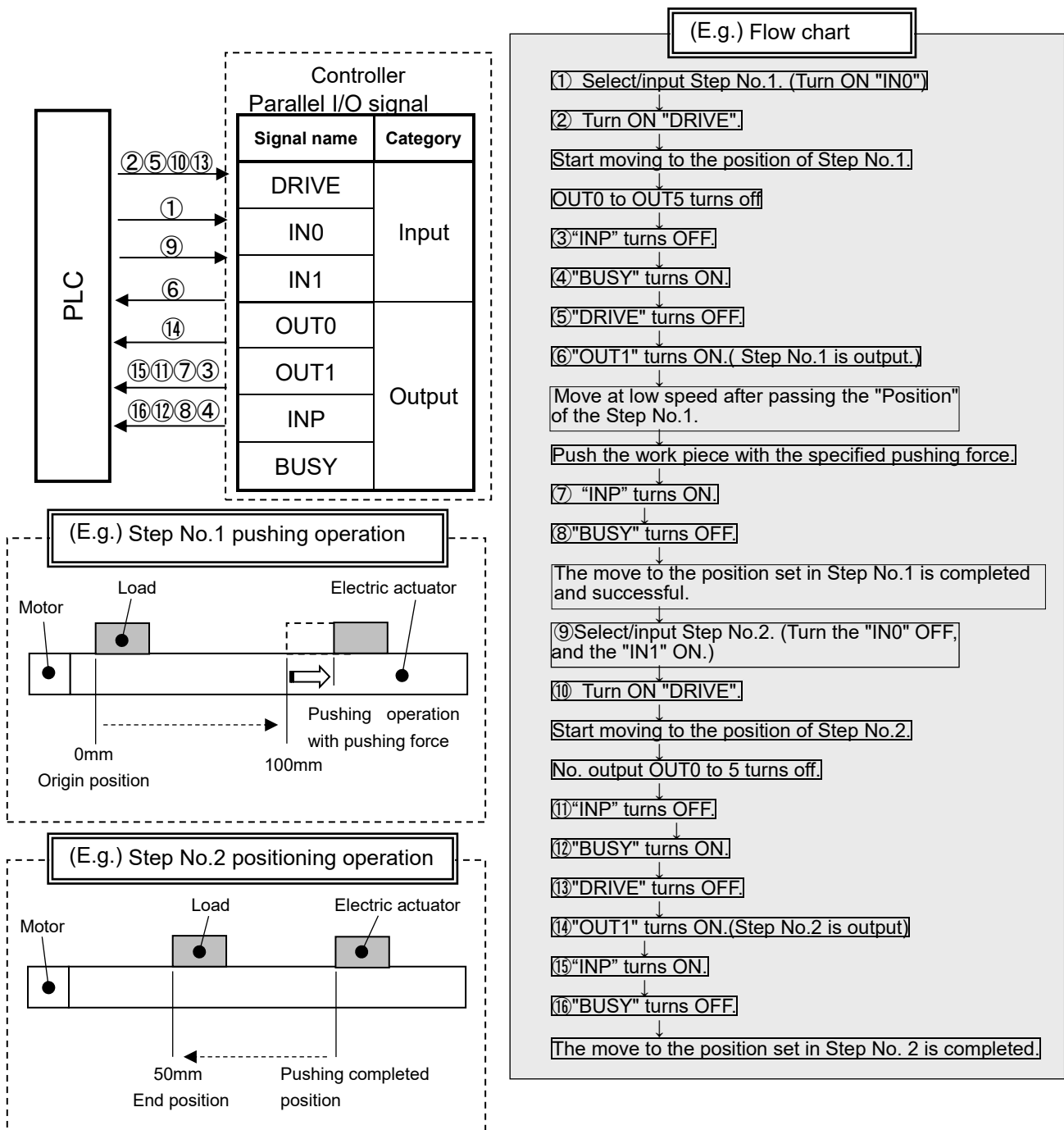



## 14. Start up procedure for battery-less absolute encoder

### 14.1 Procedure for start up

Procedure for start up of the battery-less absolute encoder for every occasion when the power is applied.

(1) When power is supplied for the first time (Refer to 14.2 for details)

In the following cases, Alarm No.10-153 "Absolute encoder ID does not match controller data" is generated after the power is applied, so perform the return to origin operation after resetting the alarm.

In addition, "When power is supplied for the first time" indicates the following cases.

- When connecting the electric actuator and turning on the power for the first time after purchase.
- When the actuator or motor has been replaced.
- When replacing the controller.

If the electric actuator and controller have been purchased as a set part number, the alarm may not be generated by the customer because the alarm No. 01-153 "Absolute encoder ID does not match controller data" is reset at the factory.

(If multiple units are purchased with the same set part number, alarm No. 01-153 "Absolute encoder ID does not match controller data" will occur depending on the combination of the connected electric actuator and controller.)

(2) When the power is supplied again (Refer to 14.3 for details)

(3) Alarm (group E) is cleared by a cut to the power supply (Refer to 14.4 for details).

SETON output is turned OFF. Perform return to origin operation.

When the power is applied again after changing Return to origin parameter "Return to Origin Direction", follow the same start up procedure.

## 14.2 When supplying power for the first time

Please refer to the following [Procedures and Timing diagram] for each operation.

### -Procedure-

- 1) Supply power
- ↓
- 2) ESTOP output is turned OFF  
ALARM output is turned ON  
OUT3 output is turned ON  
([1-153: Absolute encoder ID does not match controller data] alarm is generated)
- ↓
- 3) RESET is turned ON.
- ↓
- 4) ALARM output is turned OFF.
- ↓
- 5) SVON input is turned ON
- ↓
- 6) SVRE output is turned ON.  
\* The actuator with lock is unlocked.
- ↓
- 7) SETUP input is turned ON.
- ↓
- 8) BUSY output is turned ON.  
(Starts the operation.)
- ↓
- 9) SETON, INP output turns ON.  
Return to origin is completed when BUSY output is turned OFF.  
When return to origin operation is completed, DRIVE is available.

### -Timing diagram-

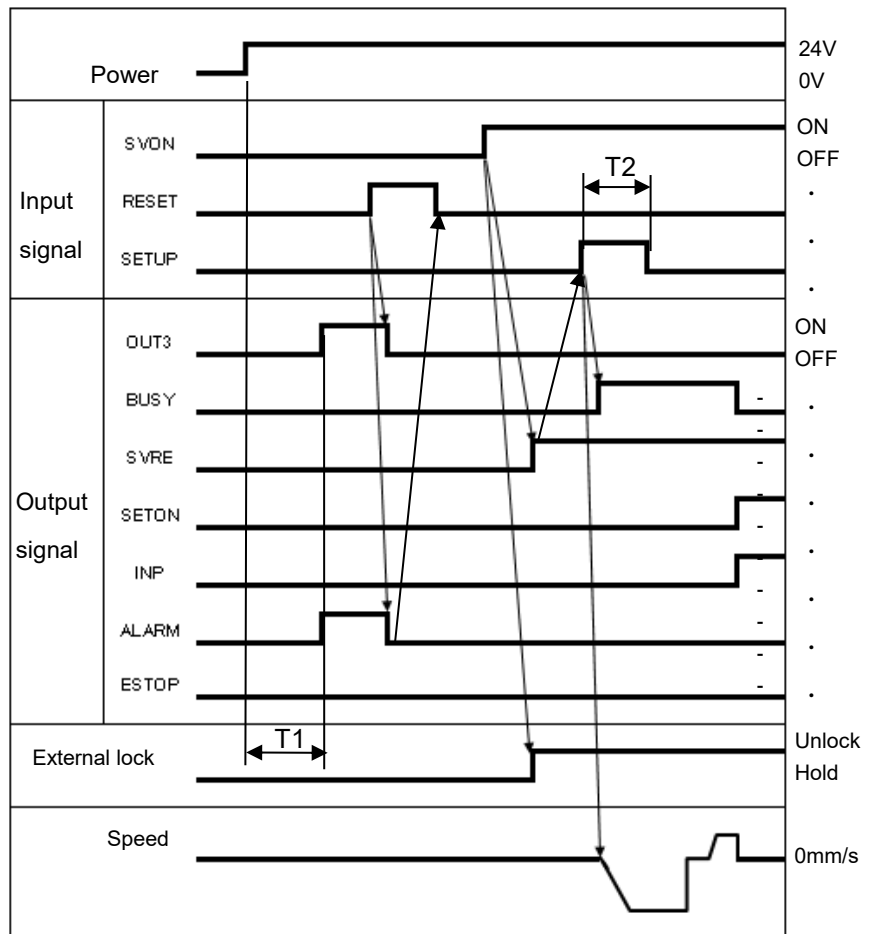

T1: 1.6 s or less (System initialize time + Time required to activate alarm)

T2: Communication cycle time: 2 times or more

### 14.3 Supply of power

(1) Power supply is turned back on (Normal)

If [ALARM] is OFF (no alarm) after supplying power again, SETON output is ON after T3.

**-Procedure-**

- 1) Supply power
- ↓
- 2) ESTOP output is turned OFF  
ALARM output is turned OFF
- ↓
- 3) SETON output is turned ON  
after T3
- ↓
- 4) SVON input is turned ON.
- ↓
- 5) SVRE output is turned ON.  
When return to origin  
operation is completed,  
DRIVE is available.

**-Timing diagram-**

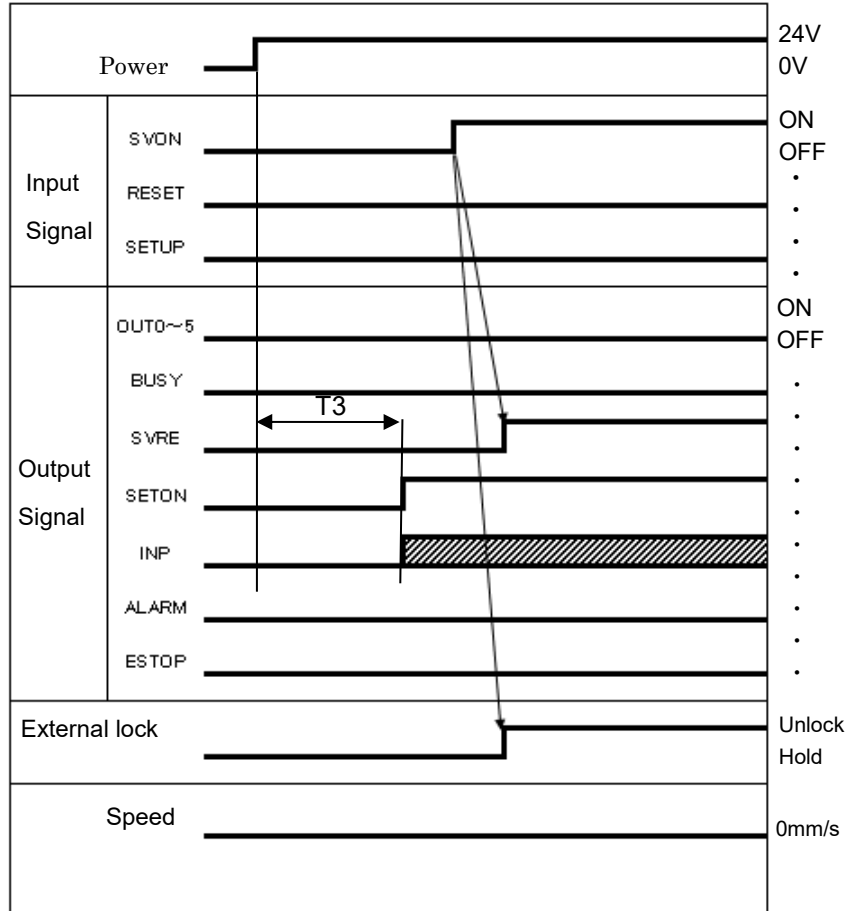

T3: 3 s or less

(System initialize time + Time required for reading position data)

## 14.4 Alarm (group E) is cleared by a cut to the power supply

It is necessary to perform the return to origin operation when alarm (group E) is generated and the alarm is cleared by shutting off the power supply. When the power is applied again after changing Return to origin parameter "Return to Origin Direction", follow the same start up procedure.

### -Procedure-

- 1) Supply power
- ↓
- 2) ALARM output turns OFF  
ESTOP output is turned OFF
- ↓
- 3) SVON input turns ON after T1 passed
- ↓
- 4) SVRE output is turned ON.  
\*The time taken for SVRE output to turn ON depends on the actuator type and the operating conditions.  
\*The actuator with lock is unlocked.
- ↓
- 5) SETUP input is turned ON.
- ↓
- 6) BUSY output is turned ON.  
(Starts the operation.)
- ↓
- 7) Return to origin is completed when SETON, INP output is turned ON and ONBUSY output is turned OFF. When return to home position is completed, .DRIVE etc. is available.

### -Timing diagram-

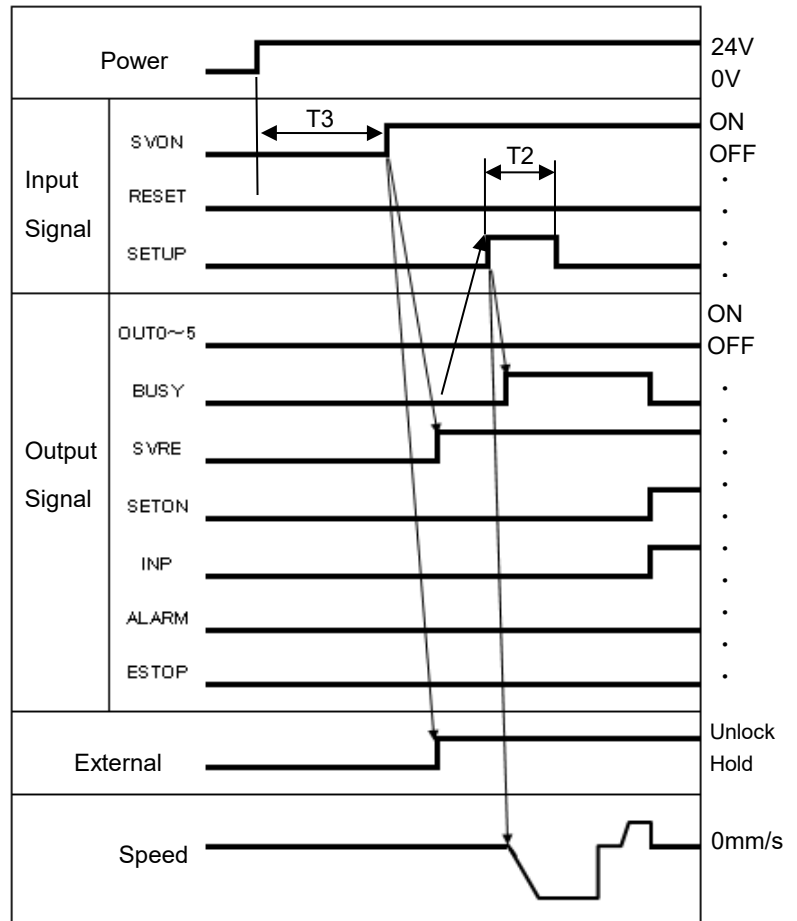

T2: Communication cycle time: 2 times or more

T3: 3 s or less (System initialize time + Time required for reading position data)

# 15. Operation Instructions

The following describes how to instruct the operation by step data No. instruction, operation by numerical instruction, and operation of the data edit function.

## 15.1 Operation procedure for Operation by Step date No.

Refer to the following "Procedures" and "Timing charts" for details of the Return to Origin, operation mode procedures and the signal timing.

### [1] Power on and Return to Origin position

**- Procedure -**

- ① Turn the power supply ON.  
When the initialization of the controller is over, RWr0, bit6: Initial is turned on.
- ↓
- ② Turn ON "SVON".
- ↓
- ③ "SVRE" turns ON.  
\* The time when "SVRE" turns ON depends on the type of electric actuator and the customers application.  
\* The electric actuator with lock is unlocked.
- ↓
- ④ Turn ON "SETUP".
- ↓
- ⑤ "BUSY" turns ON.  
(The actuator starts the operation.)  
After "BUSY" turns ON, "SETUP" will turn OFF.
- ↓
- ⑥ "SETON" and "INP" will turn ON.  
Return to origin is completed when "INP" turns ON.

**- Timing chart Power on and Return to Origin position -**

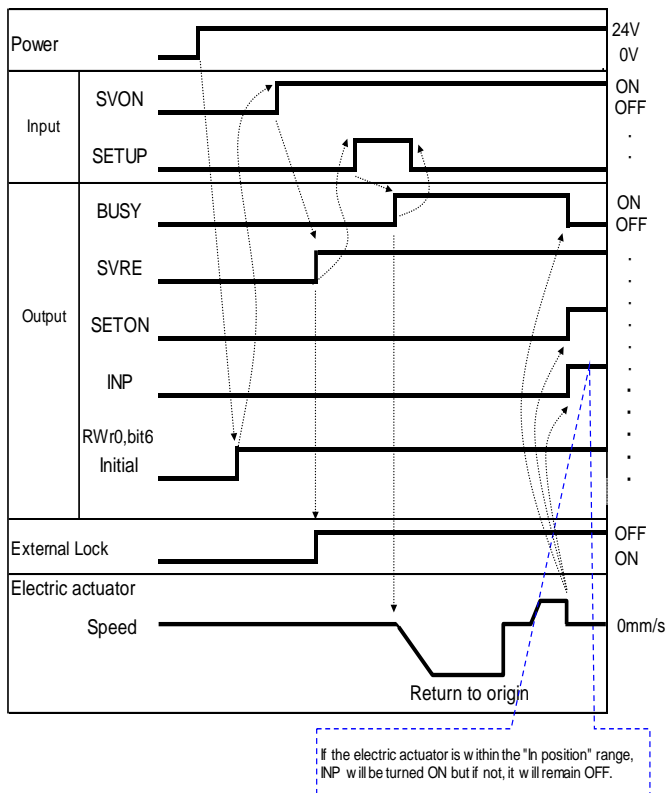

## [2] Positioning operation

### - Procedure -

- ① Input step data No. ("IN0" to "IN5")
  - ↓
- ② Turn ON the "DRIVE". (OUT0 to OUT5 is turned off)
  - Scan the step data number (From IN0 to IN5). Then, if DRIVE is turned OFF, the step data number will be output (From the output OUT0 to OUT5)
  - ↓
- ③ "BUSY" turns ON. (and the positioning movement starts.)
  - ↓
- ④ When "INP" turns ON and "BUSY" turns OFF, the positioning operation will be completed.

### - Timing chart Positioning operation -

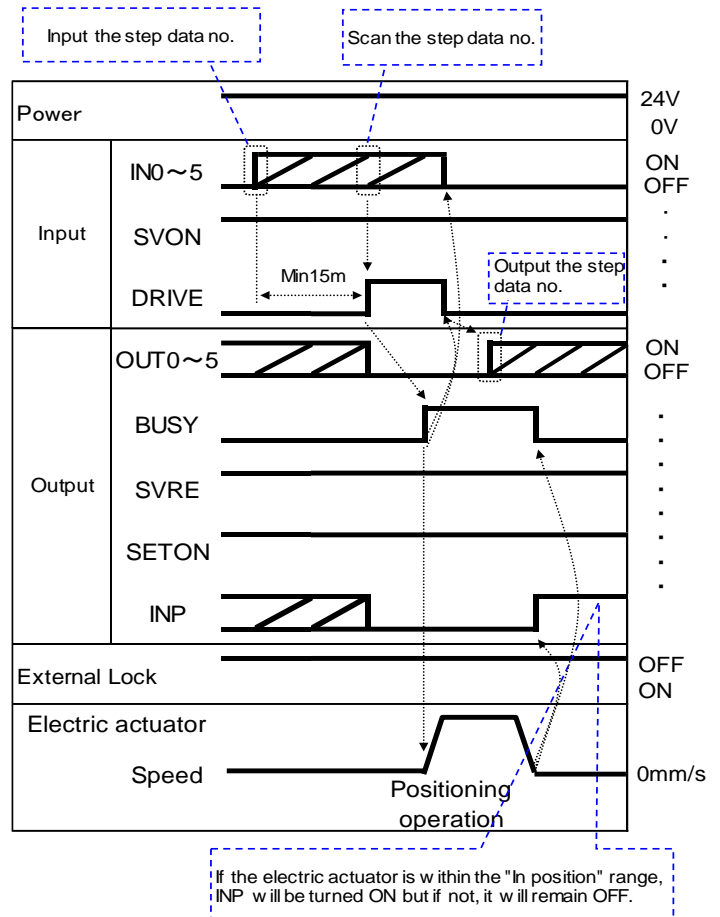

## [3] Pushing Operation

### - Procedure -

- ① Input step data No. ("IN0" to "IN5")
  - ↓
- ② Turn ON the "DRIVE". (OUT0 to OUT5 is turned off.)
  - Scan the step data number (From IN0 to IN5). After this, if DRIVE is turned OFF, the step data number will be output (From the outputs OUT0 to OUT5)
  - ↓
- ③ "BUSY" is ON when pushing starts
  - ↓
- ④ When "INP" turns ON and "BUSY" turns OFF, the pushing operation will be completed (the actuator generates the force larger than that specified in "Trigger LV" of the step data).

### - Timing chart Pushing Operation -

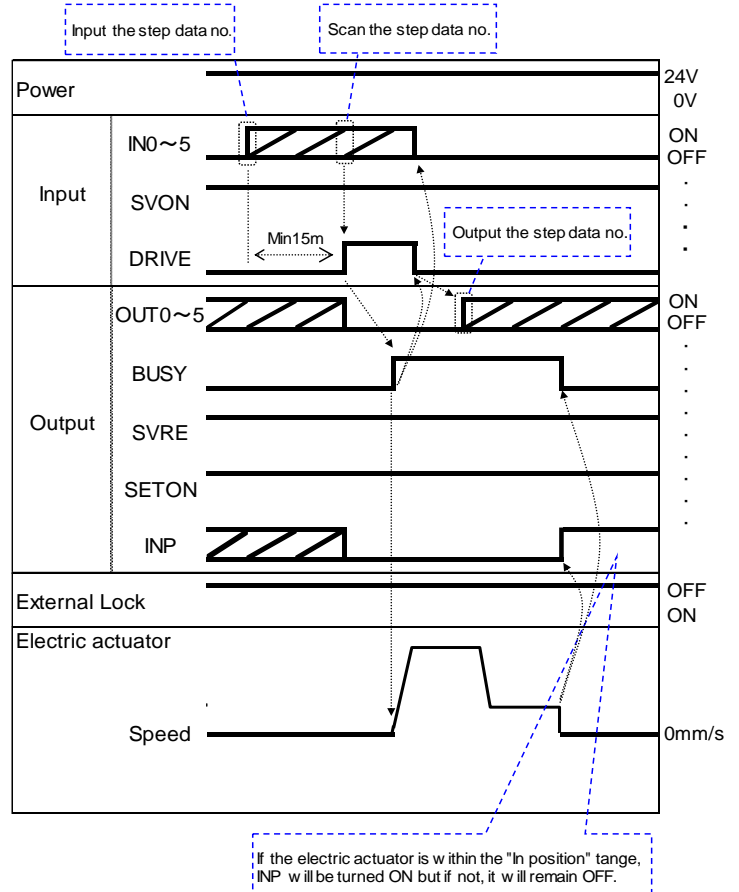

#### [4] HOLD

##### - Procedure -

① During operation ("BUSY" is ON), turn ON "HOLD".



② "BUSY" turns OFF. (The actuator stops.)



③ Turn OFF the "HOLD".



④ "BUSY" turns ON. (The actuator restarts.)

##### - Timing chart HOLD -

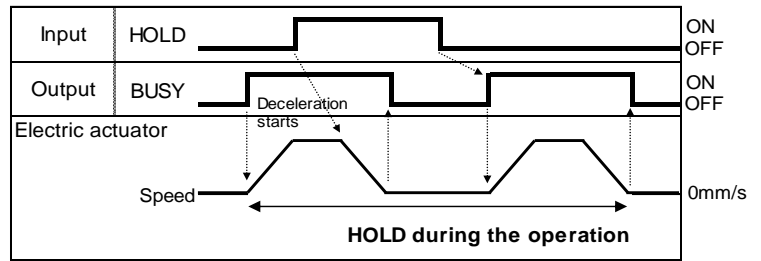

#### [5] Reset

##### -Procedure- [Driving reset]

① During operation ("BUSY" is ON) "RESET" is turned ON



② "OUT0" to "OUT5" are OFF.



③ "BUSY" are OFF. (The electric actuator stops.)

##### -Timing chart Driving reset -

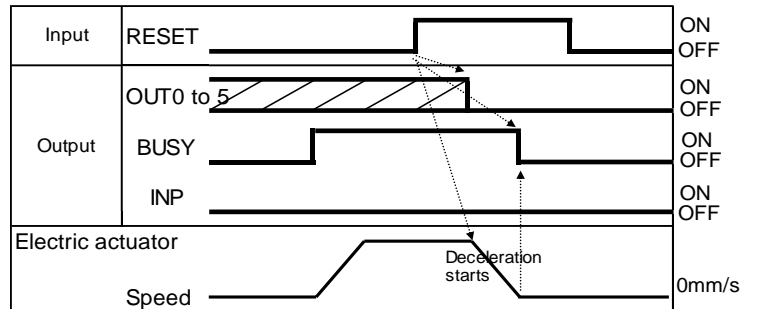

##### -Procedure- [Alarm Reset]

① Alarm generated (ALARM output turns OFF, OUT0 to OUT3 turn ON.)



② Turn ON "RESET".



③ ALARM output turns ON, OUT0 to OUT3 turn OFF. (The alarm is deactivated.)

##### -Timing chart Alarm reset

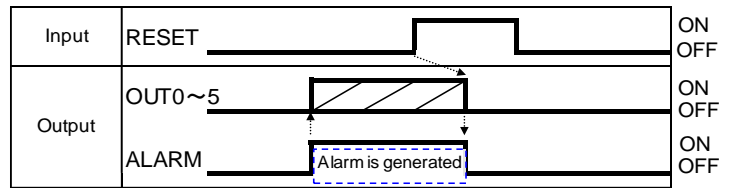

#### [6] Stop

##### - Procedure -

① During operation ("BUSY" is ON), turn OFF "EMG". (Stop command)



② "ESTOP" turns OFF.



③ "BUSY" turns OFF. (The actuator stops.) "SVRE" turns OFF.  
\*The electric actuator with lock is locked.



④ Turn ON "EMG". (The stop release command)



⑤ "ESTOP" turns ON. "SVRE" turns ON.

\*The electric actuator with lock is unlocked.

##### - Timing chart stop -

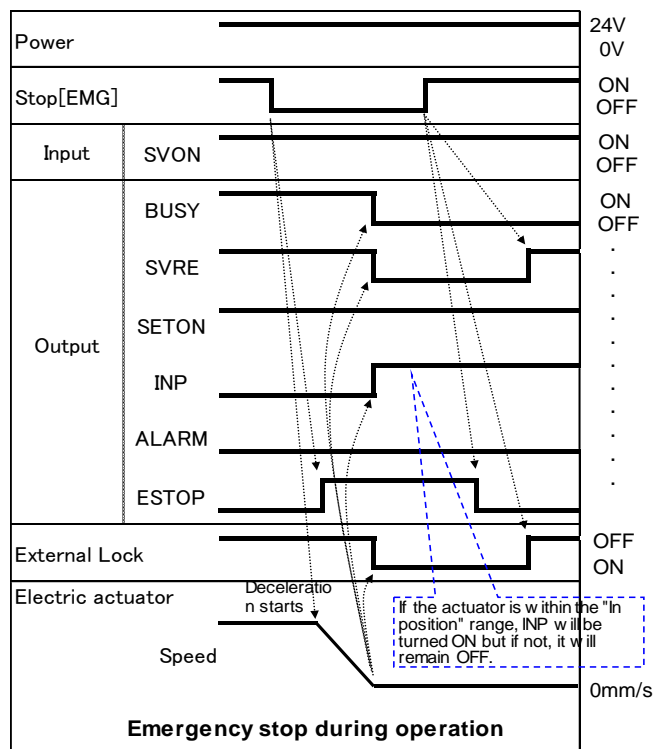

When "Stop [EMG]" is OFF, the stop is activated.

## [7] Area output

### - Procedure -

#### ● Step data No.1 operation

① Input step data No. ("IN0" to "IN5")



② Turn "DRIVE" ON.

⇒ Receive the step data no.1 (from "IN0" to "IN5").

Then, if the DRIVE is turned OFF, the step data will be output. (From the output OUT0 to OUT5).



③ "BUSY" turns ON.

(The actuator starts the operation.)  
"INP" turns OFF.



④ "AREA" of step data No.1 turns ON. (at 150mm from the origin point)



⑤ "BUSY" turns OFF. (The actuator stops.)  
"INP" turns ON.



#### ● Step data No.2 operation

⑥ Input step data No. ("IN0" to "IN5")



⑦ Turn ON "DRIVE".

⇒ Read step data No. 2 ("IN0" to "IN5")

Then, if the DRIVE is turned OFF, the step data will be output (from the output OUT0 to OUT5).



⑧ "AREA" turns OFF.

"BUSY" turns ON. (The actuator starts the operation.)

"INP" turns OFF.



⑨ "AREA" of step data No.2 turns ON. (at 170mm from the origin point)



⑩ "AREA" of step data No.2 turns OFF. (at 130mm from the origin point)



⑪ "BUSY" turns OFF. (The actuator stops.)  
"INP" turns ON.

### - Timing chart Area output -

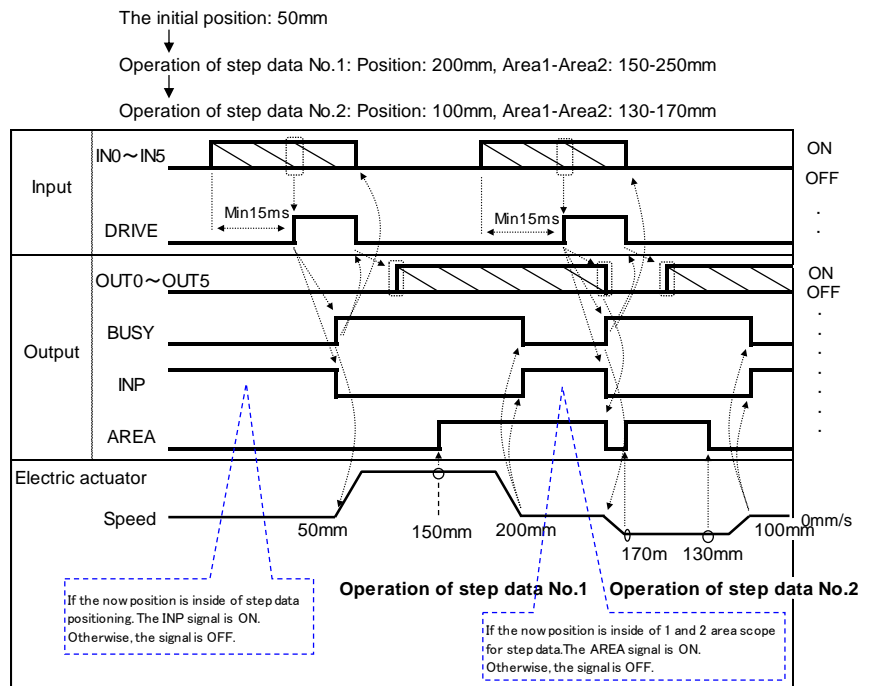



## 15.2 Operation procedure for Operation by numerical instruction

Operation by numerical instruction is possible in all modes. The following shows an example in the half numerical data instruction mode.

Enter half numerical data instruction mode and numerically instruct 50.00 mm directly for the position parameter of the specified step data No., and then operate the electric actuator. For parameters other than positions that are numerically specified (e.g. speed, acceleration/ deceleration), values set to the specified step data No. are used.

Regarding servo ON (Rx09: SVRE = ON) and fixing position information by return-to-origin (Rx0A: SETON = ON), complete these before starting operation by numerical instruction.

Timing chart/Numerical instruction operation

- ① Check that RWw1,bit0: Start flag = OFF.  
When RWw1,bit0: Start flag = ON, input "OFF".

- ② Input the step data No. to be specified in Ry00 to 05: IN0 to 5.  
Example) To specify step data No.1 →  
Input  
Ry00: IN0 = ON and Ry01 to 05: IN1 to 5 = OFF

- ③ RWw0,bit4 to F: With a numerical input flag, input ON to the parameter bit that is numerically instructed by specified step data No. Input OFF to the parameter bit that is not numerically instructed.  
Example) Only [position] of the numerical data input flag is specified by number.  
→ Input RWw0,bit6 = ON and RWw0,bit4, 5, 7 to B = OFF.

- ④ Input RWw1,bit8 to F: Operation mode and the parameter data to be numerically specified for RWw2 to 15.  
Example) Input "Position" 50.00 mm.  
5000[0.01 mm] = (00001388)h  
→ RWw3: Target position (L) = (1388)h  
RWw4: Target position (H) = (0000)h

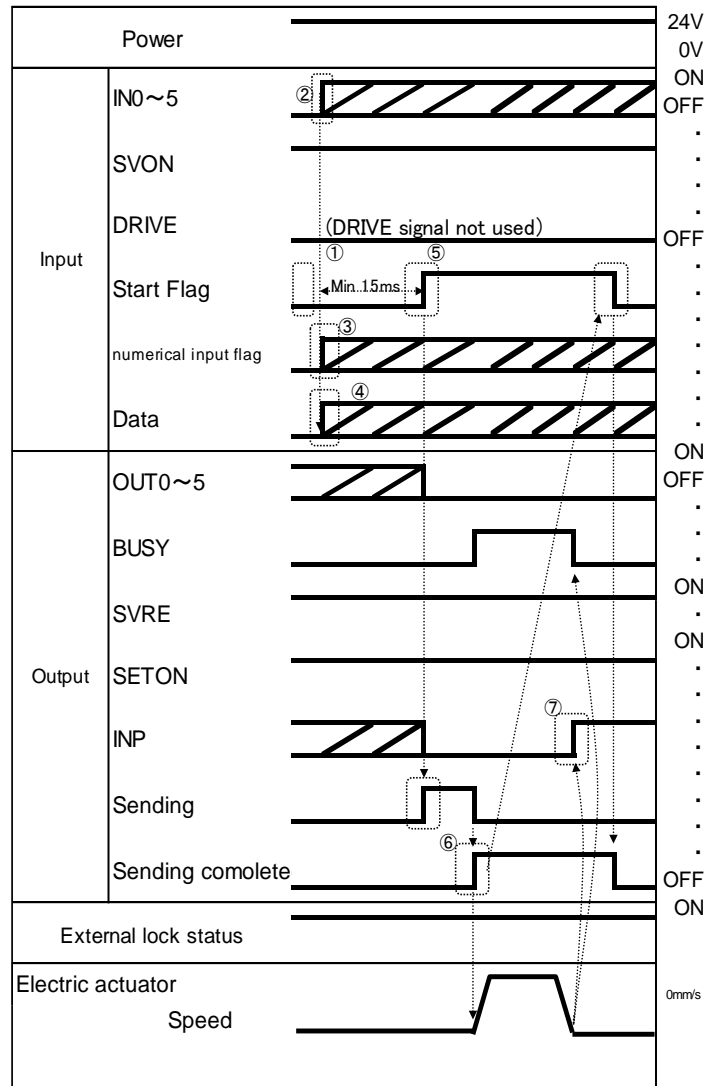

- ⑤ Input the numerical operation data input flag bit and numerical operation data, and then input RWw1, bit0: Start flag=ON.  
When the Start flag is turned ON, transmission of the operation instruction data starts and Rx00 to 05: OUT0 to 5=OFF and Rx0B: INP=OFF are output. During data transmission, RWw0,bit2: Sending=ON is output.
- ⑥ When data transmission to the electric actuator is completed, RWw0,bit2: Sending=OFF and RWw0,bit3: Sending completed=ON are output and the electric actuator starts operating.  
When the electric actuator is operating, Rx08: BUSY=ON is output.  
In addition, when RWw1,bit0: Start flag=OFF is input after RWw0,bit3: Sending completed=ON is output, RWw0,bit3: Sending completed=OFF is output.

⑦When the actuator reached the target position, Rx0B: INP=ON is output.

(Refer to **10. Memory map** for signal ON conditions)

When the actuator stops, Rx08: BUSY=OFF will be output.

The completion of the actuator operation is validated when both Rx0B: INP=ON and Rx08: BUSY=OFF are established

Please refer to "**10.1 Remote I/O (Rx and Ry)**" for details on the remote I/O (Rx and Ry) and "**10.2 Remote register (RWr and RWw)**" for details on the remote register (RWr and RWw).

### 15.3 Operating procedure for the data edit function

Data editing function is possible to be operated in Half numerical data instructions mode and Hull numerical data instructions mode.

The example using in Half numerical data instructions mode is described as follows.

Input 50.00[mm] into the position of Step No.1.However uses Half numerical data instructions.

Please details of remote IO (Rx and Ry) must refer to "**10.1 Remote I/O (Rx and Ry)**" and refer to "**10.2 Remote register (RWr and RWw)**".

(1) Check that the remote register RWw0,bit4: Start flag is OFF.

When the Start flag is ON, turn it OFF. Next, turn ON the remote register RWw0,bit1: Parameter rewrite flag.

(2) Set the data to be rewritten (Sub Function, Address, DATA) for the remote register RWw1 to 5: Data, edit and send. Please refer to "**9.5 Data edit function**" for details on data settings.

Since Position consists of two words, input the instruction code [2-word writing] (12)h in Sub Function (RWw1).

RWw1: Sub Function = (0012)h

Input the "Position" address D0412 of step data No.1 in RWw2 to 3: Address.

RWw2: Address = (0412)h

RWw3: Address = (0000)h

Input 50.00 [mm] in RWw4 to 5: DATA.

RWw4: DATA (H) = (0000)h

RWw5: DATA (L) = (1388)h

(3) When the remote register RWw0,bit4: Start flag is turned ON, the data described in (2) above is sent. During data transmission, the remote register RWr0,bit2: Sending is ON.

(4) When data transmission is completed, the remote register RWr0,bit2: Sending is turned OFF and RWr0,bit3: Sending completed is turned ON.

(5) When the remote register RWw0,bit4: Start flag is turned OFF, RWr0,bit3: Sending completed is turned OFF.

(Perform steps (6) and (7) only when you want to check the written contents.)

(6) Check that the step data has been edited correctly. Set data as described in (2).

To read step data, use the instruction code [2-word reading] (02)h to read the [Position] (address D0412) of step data No. 1.

RWw1: Sub Function = (0002)h

RWw2: Address = (0412)h

RWw3: Address = (0000)h

(7) Check that data is being transmitted and the transmission is completed by using the same procedures described in (3) and (4).

When data transmission is completed, [Position] of the step data No. 1 is output to the remote register RWr6 to 7: DATA.

RWr6:DATA (H) = (0000)h

RWr7:DATA (L) = (1388)h

(8) Check that the Step data is edited correctly. In order to complete the data editing, confirm ON of "Sending completed" by OFF of the Start flag, and then set the OFF flag of the remote register RWw0,bit1: Setting parameter rewriting.

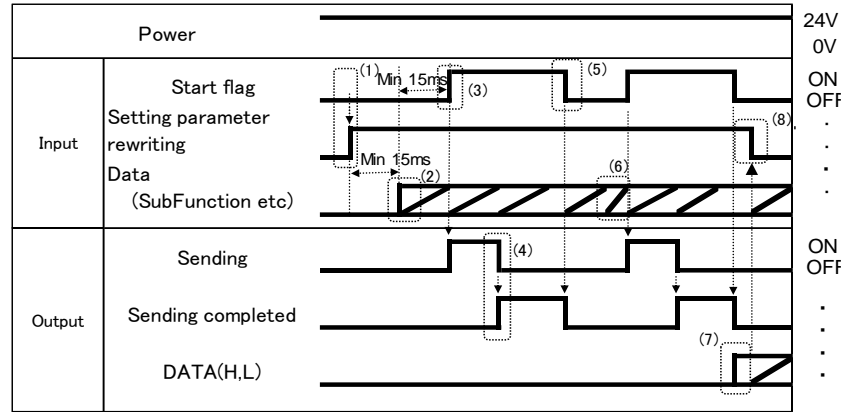

For the memory address used in the data editing function in the full numeric data instructions mode, please check "10.2 Remote register (RWr and RWw)".

## 16. Alarm for Motor Control

The details of the alarm can be checked using the controller setting software or the teaching box. Please refer to the manuals of the controller setting software or the teaching box for details of the alarms. When an alarm is generated, deactivate the alarm after troubleshooting and correcting the error with reference to chapter "**16.2 Alarms and countermeasures**".

Alarms are divided into two types. One can be cleared by inputting the remote I/O signal, RESET. The other cannot be cleared unless the control power supply (24 VDC) is turned off.

### 16.1 Output signal of Remote IO for the alarm group

This product outputs a signal to establish which type of alarm has been generated.

Alarms are classified into 4 groups. When an alarm is generated, it is output in OUT0 to 3. OUT4 and OUT5 are OFF.

The status of output terminal for each alarm group is as follows:

Alarm group	Output signal of Remote IO				
	ALARM	OUT0	OUT1	OUT2	OUT3
Alarm group B	ON	OFF	ON	OFF	OFF
Alarm group C	ON	OFF	OFF	ON	OFF
Alarm group D	ON	OFF	OFF	OFF	ON
Alarm group E	ON	OFF	OFF	OFF	OFF

When multiple alarms go off and there are different alarm groups, multiple OUT signals will turn on.

After generation of the alarm, SVRE or SETON are output according to the contents of the alarm as shown below.

Alarm group	Output signal of Remote		How to restart
	SVRE	SETON	
Alarm group B	No change	No change	Turn ON "RESET"
Alarm group C	No change	No change	Turn ON "RESET"
Alarm group D	OFF	No change	Turn ON "RESET", then turn ON "SVON". *1)
Alarm group E	OFF	OFF	Power supply for control is turned OFF



\*1) Procedure to restart operation when alarm group D is generated.

Procedure 1: Alarm group D is generated → "SVRE" changes to OFF (Servo is OFF)



Procedure 2: Turn ON RESET → (The alarm is cancelled)

→ After turning ON "SVON", "SVRE" turns ON (Servo is ON).

## 16.2 Alarms and countermeasures

Name of the controller setting software (code) *1	Teaching box description	Group	How to deactivate	Alarm contents/Countermeasure
Drive data value is wrong (01-048)	Step dataALM1	B	RESET	<p><b>&lt;Condition&gt;</b>            The step data is incorrect for the following conditions (Settable range)            (1) Area1 &lt;Area2            (If both Area1 and Area2 is 0, the alarm will not be activated.)            (2) Trigger LV ≤ Pushing force            (3) Minimum speed of actuator ≤ Pushing speed ≤ Speed            (4) Pushing speed ≤ Maximum pushing speed of actuator            (5) Pushing force ≤ Minimum pushing force of actuator            (6) Basic parameter "Maximum pushing force" ≥Minimum pushing force of the actuator            (7) Basic parameters "Max pushing force" ≥ Threshold</p> <p><b>&lt;Countermeasure&gt;</b>            Modify the step data and basic parameters setting</p> <div style="border: 1px solid black; background-color: #e0e0e0; padding: 5px; text-align: center;">  <b>Caution</b> </div> <p>Please refer to the manual or the catalogue of the actuator for the max/min pushing force/speed for the actuator.</p>
Parameter value is wrong (01-049)	Parameter ALM	B	RESET	<p><b>&lt;Contents&gt;</b>            The basic parameter is not correct for the following condition: (Settable range)            (1) Stroke(-) &lt; Stroke (+)            (2) W-Area 1 &lt; W-Area 2            (* If both W-Area1 and W-Area2 is 0, the alarm will not be activated.)            (3) Maximum pushing force &lt; Maximum pushing force of actuator</p> <p><b>&lt;Countermeasure&gt;</b>            Modify the basic parameter setting.</p> <div style="border: 1px solid black; background-color: #e0e0e0; padding: 5px; text-align: center;">  <b>Caution</b> </div> <p>Please refer to the manual or the catalogue of the actuator for the maximum pushing force for the actuator.</p>
The deceleration value is too small. (01-050)	Small Dec	B	RESET input	<p><b>&lt;Contents&gt;</b>            Step data in which a deceleration speed exceeding the stroke limit is specified.</p> <p><b>&lt;Countermeasure&gt;</b>            Modify the Deceleration value to a value with a sufficient margin so that the electric actuator can stop within the stroke limit.</p>

Set step data is not registered on list. (01-051)	Step data ALM2	B	RESET	<p><b>&lt;Contents&gt;</b> For an operation for a specific step data no., the requested number of the step data is not registered. (When operation is commanded through PLC, this alarm will be generated depending on the signal interval and the holding time of signals)</p> <p><b>&lt; Countermeasure &gt;</b> (1) Make sure that the "Movement MOD" in the step data is not "Blank (Disabled)" and that numbers [1(ABS)] and [2(INC)] or input in the numerical instruction operation. (2) Set the interval time between signals to more than twice the communication cycle time, when signals are to be continuously input, because PLC processing delays and controller scanning delays can occur. Refer to <b>15.1[2] Positioning operation.</b></p>
Set stroke is outside the stroke limit. (01-052)	Stroke limit	B	RESET	<p><b>&lt;Contents&gt;</b> The actuator goes outside the stroke limit specified by the basic parameters, "Stroke (+)" and "Stroke (-)" if it performs the requested operation. (Including JOG operation after return to origin)</p> <p><b>&lt;Countermeasure&gt;</b> Make sure that the basic parameters, "Stroke (+)" and "Stroke (-)" are consistent with the distance of actuator movement specified in the step data.</p> <div style="border: 1px solid black; padding: 5px; text-align: center;"> <p><b>⚠ Caution</b></p> <p>If the operation method of step data is INC, take care with the position where operation starts and the travel distance.</p> </div>
Alarm _Comment _058 (01-058)	3A	B	RESET	<p><b>&lt;Content&gt;</b> <b>This alarm occurs when the following parameter is outside of the settable range during the numerical instruction operation.</b> (Settable range) (1) AREA 1 &lt; AREA 2 (□ If both Area1 and Area2 are 0, the alarm will not be activated.) (2) Trigger LV ≤ Pushing force (3) Minimum speed of actuator ≤ Pushing speed ≤ Speed (4) Pushing speed ≤ Maximum pushing speed of actuator (5) Pushing force ≥ Minimum pushing force of actuator (6) Basic parameter "Maximum pushing force" ≥ Minimum pushing force of the actuator (7) Basic parameters "Maximum pushing force" ≥ Trigger LV</p> <p><b>&lt;Countermeasure&gt;</b> Modify the basic parameter setting.</p> <div style="border: 1px solid black; padding: 5px; text-align: center;"> <p><b>⚠ Caution</b></p> <p>Please refer to the operation manual or catalog of the actuator for the maximum pushing speed, minimum pushing force, and minimum speed for the actuator.</p> </div>
Alarm _Comment _061 (01-061)	3D	B	RESET	<p><b>&lt;Content&gt;</b> This alarm occurs when specifying step data based on the unregistered No. of the step data or when the numbers of the Movement MOD specify outside of range during numerical instruction operation. (When operation is commanded through PLC, this alarm will be generated depending on the input signal interval and the holding time of signals)</p> <p><b>&lt;Countermeasures&gt;</b> (1) Make sure that the "Movement MOD" in the step data is not "Blank (Disabled)" and that numbers [1(ABS)] or [2(INC)] are input in the numerical instruction operation. (2) Set the interval time between signals to more than twice the communication cycle time, when signals are to be continuously input, because PLC processing delays and controller scanning delays can occur. Refer to <b>15.1 [2] Positioning operation.</b></p>

Alarm _Comment _062 (01-062)	3E	B	RESET	<p><b>&lt;Content&gt;</b> The actuator goes outside the stroke limit specified by the basic parameters, "Stroke (+)" and "Stroke (-)" if it performs the requested operation during numerical instruction operation.</p> <p><b>&lt;Countermeasure&gt;</b> Make sure the basic parameters, "Stroke (+)" and "Stroke (-)" are consistent with the distance of actuator movement specified in the step data.</p> <table border="1" data-bbox="699 353 1453 573"> <tr> <td style="text-align: center;"> <b>Caution</b></td> </tr> <tr> <td>If the operation method of step data is "relative coordinated movement", note the location where the operation starts and the distance traveled. If the location is out of the stroke range when the power is supplied, this alarm is generated. Move the table within stroke range, and supply power.</td> </tr> </table>	 <b>Caution</b>	If the operation method of step data is "relative coordinated movement", note the location where the operation starts and the distance traveled. If the location is out of the stroke range when the power is supplied, this alarm is generated. Move the table within stroke range, and supply power.										
 <b>Caution</b>																
If the operation method of step data is "relative coordinated movement", note the location where the operation starts and the distance traveled. If the location is out of the stroke range when the power is supplied, this alarm is generated. Move the table within stroke range, and supply power.																
Reacting force is outside limit when pushing. Position is unstable. (01-096)	Pushing ALM	C	RESET	<p><b>&lt;Contents&gt;</b> In the pushing operation, the actuator is pushed back from the pushing operation origin position.</p> <p><b>&lt;Countermeasure&gt;</b> Increase the distance from the pushing operation origin position to the object being pushed. Or, increase the pushing force.</p>												
Return to ORIG did not complete in the set time. (01-097)	ORIG ALM	C	RESET	<p><b>&lt;Contents&gt;</b> Return to origin is not completed within the set time.</p> <p><b>&lt;Countermeasure&gt;</b> Make sure there are no obstructions that interfere with the actuator movement.</p>												
Drive is ON when SVRE is OFF (01-098)	Servo OFF ALM	C	RESET	<p><b>&lt;Contents&gt;</b> While the servo is off (when EMG terminal is not energized), the return to origin operation, positioning operation, pushing operation or JOG operation is requested.</p> <p><b>&lt;Countermeasure&gt;</b> Modify the setting so that those operations will be requested while the servo motor is ON ("SVRE" is ON).</p>												
Drive is ON when SETON is OFF (01-099)	Drive ALM	C	RESET	<p><b>&lt;Contents&gt;</b> A positioning operation or pushing operation is requested before the return to origin position is completed.</p> <p><b>&lt;Countermeasure&gt;</b> Modify the setting so that these operations will be requested after the return to origin position is completed.</p>												
Motor was not stationary when ABS encoder was communicating. (01-101)	Polarity not found	C	Turn ON RESET	<p><b>&lt;Contents&gt;</b> The power is applied when the actuator is operated by an external force.</p> <p><b>&lt;Countermeasure&gt;</b> Make sure the actuator is stopped and then turn ON RESET.</p>												
Did not detect sensor when returning to ORIG. (01-103)	ORIG Sens ALM	C	RESET	<p><b>&lt;Contents&gt;</b> Alarm is generated when return parameter has the conditions 1, 2 shown below.</p> <table border="1" data-bbox="699 1688 1458 1951"> <thead> <tr> <th colspan="3">Return to origin parameter setting</th> </tr> <tr> <th></th> <th>Return to origin mode</th> <th>ORIG sensor</th> </tr> </thead> <tbody> <tr> <td>1</td> <td>Pushing origin operation [Stop]</td> <td>•Sensor N.O type [N.O]</td> </tr> <tr> <td>2</td> <td>Limit switch origin [Sensor]</td> <td>•The origin sensor is not effective. [Disabled] or •Sensor N.O type [N.O]</td> </tr> </tbody> </table> <p>* Alarm is generated with the conditions above when the sensor is not mounted to the actuator.</p> <p><b>&lt;Countermeasure&gt;</b> Check the sensor installation and settings of the return to origin parameter.</p>	Return to origin parameter setting				Return to origin mode	ORIG sensor	1	Pushing origin operation [Stop]	•Sensor N.O type [N.O]	2	Limit switch origin [Sensor]	•The origin sensor is not effective. [Disabled] or •Sensor N.O type [N.O]
Return to origin parameter setting																
	Return to origin mode	ORIG sensor														
1	Pushing origin operation [Stop]	•Sensor N.O type [N.O]														
2	Limit switch origin [Sensor]	•The origin sensor is not effective. [Disabled] or •Sensor N.O type [N.O]														

Absolute encoder communication error. (01-106)	AbEnc Comm ALM	C	Input RESET	<p><b>&lt;Contents&gt;</b> When an error is detected in the communication with the absolute encoder when power is applied. When the wiring of the encoder and controller is disconnected.</p> <p><b>&lt;Countermeasure&gt;</b> Check the connector of the controller and actuator wiring is not loose or the cable is not damaged.</p>
Speed exceeded set value (01-144)	Over speed	D	RESET SVON	<p><b>&lt;Contents&gt;</b> The motor speed exceeds a specific level due to an external force, etc.</p> <p><b>&lt;Countermeasure&gt;</b> Make improvements so that the motor speed will not exceed the maximum speed of the electric actuator.</p> <div data-bbox="699 483 1460 607" style="border: 1px solid black; padding: 5px;"> <p style="text-align: center;"> <b>Caution</b></p> <p>Please refer to the manual or the catalogue of the electric actuator for the maximum speed of the electric actuator.</p> </div>
Motor power supply voltage is outside set range. (01-145)	Over motorVol	D	RESET SVON	<p><b>&lt;Contents&gt;</b> This alarm is generated when the motor power-supply voltage, which is detected by the controller, is outside the specified range. The controller checks the lower limit of the motor power supply voltage only when the servo [SVRE] is ON.</p> <p><b>&lt;Countermeasure&gt;</b> Make sure that the voltage supplied to the motor power (M24V) of the controller is within specification.</p> <div data-bbox="699 891 1460 1014" style="border: 1px solid black; padding: 5px;"> <p style="text-align: center;"> <b>Caution</b></p> <p>If the power supply is "inrush-current control type", a voltage drop may cause an alarm during acceleration/deceleration.</p> </div> <p><b>&lt;Contents&gt;</b> The alarm may be caused by regenerative power depending on the method of operation of the electric actuator.</p> <p><b>&lt;Countermeasure&gt;</b> Make sure that the operating conditions are within the specifications.</p> <div data-bbox="699 1227 1460 1350" style="border: 1px solid black; padding: 5px;"> <p style="text-align: center;"> <b>Caution</b></p> <p>Please refer to the manual or the catalogue of the electric actuator for the method of operation of the electric actuator.</p> </div>
Controller temperature exceeded set range. (01-146)	Over Temp	D	RESET SVON	<p><b>&lt;Details&gt;</b> The temperature around the power element of the controller is too high.</p> <p><b>&lt;Countermeasures&gt;</b> Make improvements so that the temperature around the controller is kept appropriate.</p>



Controller supply voltage is outside set range. (01-147)	Over CrtlVol	D	RESET SVON	<p><b>&lt;Contents&gt;</b> The control power supply voltage within the controller is outside the set range.</p> <p><b>&lt;Countermeasure&gt;</b> Make sure that the voltage supplied to the control power (C24V) of the controller is appropriate.</p> <div style="border: 1px solid black; background-color: #cccccc; text-align: center; padding: 2px;"><b>⚠ Caution</b></div> <p>If a single power supply is used for both the control power and the motor power, or the power supply is "inrush-current control type", a power voltage drop may be caused due to a voltage drop during acceleration/deceleration.</p>
				<p><b>&lt;Contents&gt;</b> The alarm may be caused by regenerative power depending on the method of operation of the electric actuator.</p> <p><b>&lt;Countermeasure&gt;</b> Make sure that the operating conditions are within the specifications.</p> <div style="border: 1px solid black; background-color: #cccccc; text-align: center; padding: 2px;"><b>⚠ Caution</b></div> <p>Please refer to the manual or the catalogue of the electric actuator for the method of operation of the electric actuator.</p>
Current limit is exceeded (01-148)	Over load	D	RESET SVON	<p><b>&lt;Contents&gt;</b> The output current accumulated value exceeds the specified value.</p> <p><b>&lt;Countermeasure&gt;</b> Make sure there are no obstructions that interfere with the electric actuator movement. Also, make sure that the load, speed, acceleration and deceleration are within the range of the electric actuator.</p>
The target position was not reached within the set time limit (01-149)	Posn failed ALM	D	RESET SVON	<p><b>&lt;Content&gt;</b> Failed to reach the set position within the set time limit.</p> <p><b>&lt;Content&gt;</b> Make sure there are no obstructions that interfere with the electric actuator movement. Also, make sure that the load, speed, acceleration and deceleration are within the range of the electric actuator.</p>

Communication error. (01-150)	Ctrl Comm ALM	D	RESET Input SVON or Turn off the Control Power and power supply	<p><b>&lt;Contents&gt;</b> This alarm is generated when connection fails while the electric actuator is operated from an upper-level device.</p> <p><b>&lt;Countermeasure&gt;</b> Do not interrupt the connection between the PC and teaching box when the electric actuator is being operated by upper-level devices.</p> <p>*2) Check the connection with the upper level devices, and then reset alarms according to the states of the following LED and flags.</p> <p>In case of the communication failure of the PC or teaching box, resetting of alarm by PC or teaching box is possible after connecting again.</p> <p>Communication failure with PLC only occurs when 10 is selected for "Undefined parameter 11" of the basic parameter. In this case, reset the alarms as described in the following table.</p>															
				<table border="1"> <thead> <tr> <th>LED (LRUN)</th> <th>The abnormal station detection RWr0, bit F</th> <th>Cause of communication error (Upper-level device)</th> <th>Alarm clear method</th> </tr> </thead> <tbody> <tr> <td rowspan="2">ON</td> <td>ON</td> <td>PLC</td> <td>Turn on RWw0, bit 2: Reset flag, and then turn ON Ry0B: RESET.</td> </tr> <tr> <td>OFF</td> <td>PC/TB</td> <td>Turn ON Ry0B: RESET</td> </tr> <tr> <td>OFF</td> <td>-</td> <td>PLC or PC/TB</td> <td>Power off controlled source and PLC</td> </tr> </tbody> </table>	LED (LRUN)	The abnormal station detection RWr0, bit F	Cause of communication error (Upper-level device)	Alarm clear method	ON	ON	PLC	Turn on RWw0, bit 2: Reset flag, and then turn ON Ry0B: RESET.	OFF	PC/TB	Turn ON Ry0B: RESET	OFF	-	PLC or PC/TB	Power off controlled source and PLC
				LED (LRUN)	The abnormal station detection RWr0, bit F	Cause of communication error (Upper-level device)	Alarm clear method												
				ON	ON	PLC	Turn on RWw0, bit 2: Reset flag, and then turn ON Ry0B: RESET.												
					OFF	PC/TB	Turn ON Ry0B: RESET												
OFF	-	PLC or PC/TB	Power off controlled source and PLC																
PC: Computer, TB: Teaching box																			
Absolute encoder ID does not match controller data. (01-153)	AbEnc ID ALM	D	Turn ON RESET, SVON and SETUP	<p><b>&lt;Contents&gt;</b> The controller detects the absolute encoder specific No. when power is re-applied. This specific No. is different from the number which has been connected before.</p> <p><b>&lt;Countermeasure&gt;</b> This alarm is generated when the product is used for the first time, or when the actuator or controller is replaced. Turn ON RESET to reset the alarm.</p>															
Encoder error (01-192)	Encoder ALM	E	Turn OFF and ON the power supply for the controller	<p><b>&lt;Contents&gt;</b> Abnormality in communication with the encoder.</p> <p><b>&lt;Countermeasure&gt;</b> Check the connection of the actuator cable.</p>															
Unable to find motor phase in set time. (01-193)	Polarity not found	E	Turn OFF and ON the power supply for the controller	<p><b>&lt;Contents&gt;</b> Selected sensor type is not correct</p> <p><b>&lt;Countermeasure&gt;</b> Check if the sensor type is set to "1(INC)".</p>															
Output current limit is exceeded set value (01-194)	Over current	E	Turn OFF and ON the power supply for the controller	<p><b>&lt;Contents&gt;</b> The output current of the power circuit is abnormally high.</p> <p><b>&lt;Countermeasure&gt;</b> Make sure that there are no short circuits of actuator cables, connectors, etc. In addition, make sure that the electric actuator is compatible with the controller.</p>															

I sens ALM (1-195)	I sens ALM	E	Turn OFF and ON the power supply for the controller	<p><b>&lt;Contents&gt;</b> An abnormality is detected by the current sensor that is checked when the controller is reset.</p> <p><b>&lt;Countermeasure&gt;</b> Make sure that the electric actuator conforms to the controller. When a command to turn on servo is given, check if LK RLS is energized by installing the electric actuator vertically in order to check if the motor is driven by an external force. Even after this measure, if the alarm regenerates when the power is reapplied, please contact SMC.</p>
Error counter overflowed (01-196)	Err overflow	E	Turn OFF and ON the power supply for the controller	<p><b>&lt;Contents&gt;</b> An overflow of the position error counter inside of the controller has occurred.</p> <p><b>&lt;Countermeasure&gt;</b> Make sure there are no obstructions that interfere with the electric actuator movement. Also, make sure that the load, speed, acceleration and deceleration are within the range of the electric actuator.</p>
Memory Abnormality has occurred (01-197)	Memory ALM	E	Turn OFF and ON the power supply for the controller	<p><b>&lt;Contents&gt;</b> An error of the EEPROM has occurred.</p> <p><b>&lt;Countermeasure&gt;</b> Please contact SMC. (The write limit of the EEPROM is roughly 100,000 times)</p>
CPU error (01-198)	CPU failure	E	Turn OFF and ON the power supply for the controller	<p><b>&lt;Contents&gt;</b> The CPU is not operating normally. (It is possible that the CPU or surrounding circuits has failed, or the CPU is malfunctioning due to electrical noise).</p> <p><b>&lt;Countermeasure&gt;</b> If the alarm cannot be deactivated even after the power is reapplied, please contact SMC.</p>
Alarm _Comment _0201 (01-201)	C9	E	Shut power supply off	<p><b>&lt;Contents&gt;</b> The controller detects an error in the absolute encoder No. when the power is re-applied.</p> <p><b>&lt;Countermeasure&gt;</b> If the alarm cannot be deactivated even after the power is re-applied, please contact SMC.</p>
Alarm _Comment _0202 (01-202)	CA	E	Shut power supply off	<p><b>&lt;Contents&gt;</b> The controller detects an error in the absolute encoder internal data when the power is re-applied.</p> <p><b>&lt;Countermeasure&gt;</b> If the alarm cannot be deactivated even after the power is re-applied, please contact SMC.</p>
CC-Link Communication error (01-206)	CC-Link WDT Abnormality detected	E	control power supply off	<p><b>&lt;Contents&gt;</b> This alarm is generated when a CC-Link communication error has occurred and the WDT (Watch Dog Timer) in the controller has reached the time limit.</p> <p><b>&lt;Countermeasure&gt;</b> Please contact SMC when this alarm is generated.</p>

\*1) When an alarm for the remote register (RW<sub>r</sub>) is generated, only the portion of "□□□" in the code "01-□□□" is output.

Please refer to "**10.2 Remote register (RW<sub>r</sub> and RW<sub>w</sub>)**" for details on the remote register.

## 17. Alarm Detection for CC-Link Communication

The contents of the alarms related to CC-Link communication can be checked by referring to the LED indicator on the controller or the corresponding memory in the CC-Link.

When an alarm is generated, refer to the following to take countermeasures or make corrections, and then reset the alarm.

Alarms are divided into two types. One can be cleared by inputting the RESET signal. The other cannot be cleared unless the control power supply (C 24V) is turned off.

### 17.1 Alarm details

- The following tables show alarm details that can be confirmed by Controller LED display.

Controller state	LED name and display				Alarm clear method	Contents , Countermeasure									
	PWR	ALM	LRUN	LERR											
CPU ROM+RAM check error	-	-	Green On	Red On	Power off	<p><b>&lt;Contents&gt;</b> Checksum error of built-in flash or RAM check error was occurred with communication CPU.</p> <p><b>&lt;Countermeasure&gt;</b> If the alarm cannot be deactivated even after the power is reapplied, please contact SMC.</p>									
CC-Link Communication stop	-	-	Off	Off	Turn ON the reset flag, and then input RESET or turn OFF the control power supply.	<p><b>&lt;Contents&gt;</b> Communication time-out and communication abnormality occurred in CC-Link.</p> <p><b>&lt;Countermeasure&gt;</b> Check the connection with the upper-level device, and then reset the alarm according to the state of the LRUN LED on the PLC and the JXCM1 flag status.</p> <table border="1"> <thead> <tr> <th>PLC LED (LRUN)</th> <th>JXCM1 The abnormal station detection flag RWw0,bit F</th> <th>Alarm clear method</th> </tr> </thead> <tbody> <tr> <td>ON</td> <td>ON</td> <td>Turn on RWw0, bit 2: Reset flag, and then turn on Ry0B: RESET.</td> </tr> <tr> <td>OFF</td> <td>-</td> <td>Power off controlled source and PLC</td> </tr> </tbody> </table>	PLC LED (LRUN)	JXCM1 The abnormal station detection flag RWw0,bit F	Alarm clear method	ON	ON	Turn on RWw0, bit 2: Reset flag, and then turn on Ry0B: RESET.	OFF	-	Power off controlled source and PLC
PLC LED (LRUN)	JXCM1 The abnormal station detection flag RWw0,bit F	Alarm clear method													
ON	ON	Turn on RWw0, bit 2: Reset flag, and then turn on Ry0B: RESET.													
OFF	-	Power off controlled source and PLC													
CC-Link CRC error	-	-	Off	Red On	Turn ON the reset flag, and then input RESET or turn OFF the control power supply.	<p><b>&lt;Contents&gt;</b> The CRC error occurred in CC-Link.</p> <p><b>&lt;Countermeasure&gt;</b></p> <ul style="list-style-type: none"> <li>When CC-Link communication is available Turn ON RWw0,bit3: Restart flag. In addition, when the undefined parameter 11 (Operation-setting parameter at CC-Link communication error) is 10, turn ON the RWw0,bit2: Reset flag, and then turn ON Ry0B: RESET.</li> <li>When CC-Link communication is unavailable Turn OFF the control power supply.</li> </ul>									
STATION No. error	-	-	Green flashing	Red On	Power off	<p><b>&lt;Contents&gt;</b> This error is generated when a station number that is outside the station-number setting range (1 to 63) is set by the rotary switch (STATION No.).</p> <p><b>&lt;Countermeasure&gt;</b> Check whether the rotary switch (STATION No.) is set correctly.</p>									

Communication speed error (unused range)	-	-	Green On	Red flashing	Power off	<p><b>&lt;Contents&gt;</b> When Rotary Switch (B RATE) is set within the range (5 to 9) of unused, the alarm will be occurred.</p> <p><b>&lt;Countermeasure&gt;</b> Please confirm whether the setting of Rotary Switch (B RATE) is correct.</p>
WDT Time-out error	-	-	Green flashing	Red flashing	Power off	<p><b>&lt;Contents&gt;</b> The WDT time-out was generated by communication CPU.</p> <p><b>&lt;Countermeasure&gt;</b> If the alarm cannot be deactivated even after the power is reapplied, please contact SMC</p>

—: The LED display is unrelated

- The following table shows the details for the alarms that can be checked by referring to the corresponding memory on the CC-Link, and the countermeasures for them.

Controller state	RW <sub>r</sub>						Alarm clear method	Contents , Countermeasure
	0				6 (2 Stations)	C (4 Stations)		
	bit5	bitD	bitE	bitF	0—F	0—F		
Data editing error received (Address is out of range) *1)	ON	ON	-	-	0002h	-	RW <sub>w</sub> 0,bit2: Reset flag ON	<p><b>&lt;Contents&gt;</b> When the setting of the reading/writing start number is out of address range, or when writing in a number (address) which is not permitted, this alarm will happen.</p> <p><b>&lt;Countermeasure&gt;</b> Please confirm whether the reading/writing number (address) is correct.</p>
					-	0002h		
Data editing error received (Number of access points is out of range) *1)	ON	ON	-	-	0003h	-	RW <sub>w</sub> 0,bit2: Reset flag ON	<p><b>&lt;Contents&gt;</b> When the setting of the reading/writing final number is out of the range, this alarm will happen.</p> <p><b>&lt;Countermeasure&gt;</b> Please confirm whether the reading/writing data is correct.</p>
					-	0003h		
Parameter anomaly detection	ON	-	ON	-	-	-	Turn on RW <sub>w</sub> 0,bit 2: Reset flag	<p><b>&lt;Contents&gt;</b> There is a mistake in the Input / Output flag etc. specified from PLC. The conditions that Parameter anomaly detection becomes ON are as follows. (a) When use in Numerical data instructions operation -RW<sub>w</sub>0,bit4 to C: Setting numerical data is not set correctly. (b) When use in Step data editing function -When write in an address which is not permitted. -When the setting of the reading / writing start address number is out of range.</p> <p><b>&lt;Countermeasure&gt;</b> Please confirm whether the 'Setting numerical data' flag and the data at the time of parameter rewriting is correct.</p>
Abnormal station detection	ON	-	-	ON	-	-	R Turn on RW <sub>w</sub> 0,bit 2: Reset flag or Power off	<p><b>&lt;Contents&gt;</b> Abnormality of the communication system in the JXCM1 controller.</p> <p><b>&lt;Countermeasure&gt;</b> Clear the alarm according to the Alarm clear method. If the alarm is still generated, please contact SMC.</p>

\*1) Only in Parameter writing mode

-: ON, OFF does no matter

## 18. Precautions for wiring and cable

### Warning

- (1) Adjusting, mounting or wiring change should never be done before shutting OFF the power supply to the product.**  
Electric shock, malfunction and damage can result.
- (2) Do not disassemble the cable. Use only specified cables.**
- (3) Do not connect or disconnect the cable or connector with the power on.**

### Caution

- (1) Wire the connector securely. Do not apply any voltage to the terminals other than those specified in the Operation Manual.**
- (2) Wire the connector securely.**  
Check for correct connector wiring and polarity.
- (3) Take appropriate measures against noise.**  
Noise in a signal line may cause malfunction.  
As a countermeasure, high voltage and low voltage cables should be separated, and keep wiring lengths short, etc.
- (4) Do not route wires or cables together with power or high voltage cables.**  
The product may malfunction due to interference and surge voltages. Route the wires of the product separately from power or high voltage cables.
- (5) Take care that actuator movement does not damage cables.**
- (6) Operate with cables secured. Avoid bending cables at sharp angles where they enter the product.**
- (7) Avoid twisting, folding, rotating or applying an external force to the cable. Also avoid operating at sharp angles.**  
Risk of electric shock, broken wires, contact failure and loss of control of the product can occur.
- (8) Fix the motor cable protruding from the product in place before using.**  
The motor cable is not robotic type cable and can be damaged when moved.  
Do not place Part A in the diagram below in a flexible cable duct.

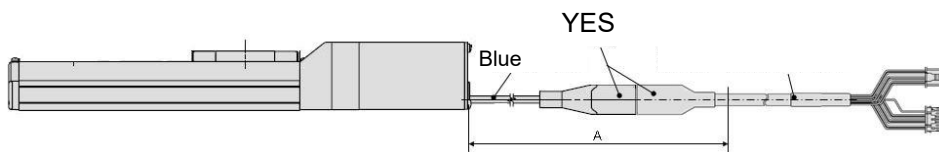

- (9) Select "Robotic type cables" when deflecting actuator-cables repeatedly. Do not put cables into a flexible moving tube with a radius smaller than the specified value (minimum 50mm).**  
Risk of electric shock, wire damage, contact failure and loss of control of the product can occur if "Standard cables" are used in case of inflecting the cables repeatedly.

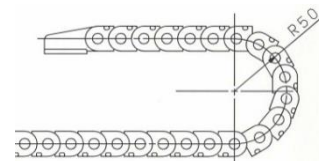

- (10) Confirm proper wiring of the product.**

Insulation failure (interference with another circuit, poor insulation between terminals etc.) could introduce excessive voltage or current to the controller or its peripheral devices and damage them.

**(11) The Speed/pushing force may vary, depending on the cable length, load and mounting conditions etc.**

If the cable length exceeds 5m, the speed/pushing force will be reduced 10% per 5 m maximum.  
(If cable length is 15m, 20% reduction maximum.)

**【Transport】**



**Do not carry or swing the product by the motor or the cable.**

## **19. Electric Actuators/Common Precautions**

### **19.1 Design and selection**

 **Warning**

**(1) Read the Operation Manual before using the product.**

Handling or usage/operation other than that specified in the Operation Manual may lead to breakage and product failure.

Any damage attributed to use beyond the specifications is not guaranteed.

**(2) There is a possibility of dangerous sudden action by the product if sliding parts of machinery are twisted due to external forces etc.**

In such cases, human injury may occur, such as catching hands or feet in the machinery, or damage to the machinery itself may occur. The machinery should be designed to avoid such dangers.

**(3) A protective cover is recommended to minimize the risk of personal injury.**

If a driven object and moving parts of the product are in close proximity, personal injury may occur. Design the system to avoid contact with the human body.

**(4) Securely tighten all stationary parts and connected parts so that they will not become loose.**

When the product operates with high frequency or is installed where there is a lot of vibration, ensure that all parts remain secure.

**(5) Consider a possible loss of power source.**

Take measures to prevent injury and equipment damage in the case of a power supply failure.

**(6) Consider the behavior of an emergency stop of the whole system.**

Design the system so that human injury and/or damage to machinery and equipment will not be caused, when it is stopped by a safety device for abnormal conditions such as a power outage or a manual emergency stop of the whole system.

**(7) Consider the action when operation is restarted after an emergency stop or abnormal stop of the whole system.**

Design the system so that human injury or equipment damage will not occur upon restart of operation of the whole system.

**(8) Disassembly and modification is prohibited.**

Do not disassemble the product or make any modifications, including additional machining. This may cause human injury and/or an accident.

**(9) Do not use the stop signal, "EMG" of the controller and stop switch on the teaching box as the emergency stop for the system.**

The stop signal, "EMG" of the controller and the stop switch on the teaching box are for decelerating and stopping the actuator. Design the system with an emergency stop circuit which is applied to the relevant safety standard separately.

**(10) When using for vertical applications, it is necessary to build in a safety device.**

The rod may fall due to the weight of the work.

The safety device should not interfere with normal operation of the machine.



## **Caution**

### **(1) Use the product for the maximum usable stroke.**

The product will be damaged if it is used with a stroke exceeding the maximum stroke. Refer to the specifications of the product.

### **(2) When the product repeatedly cycles with partial strokes, operate it at a full stroke at least once a day or every 1,000 strokes.**

Otherwise, lubrication can be lost.

### **(3) Do not use the product in applications where excessive external force or impact force is applied to it.**

The product can be damaged. Components, including the motor, are manufactured to precise tolerances, so the slight test deformation may cause faulty operation or seizure.

### **(4) Return to origin cannot be carried out during operating.**

This function cannot be carried out during positioning operation or pushing operation.

### **(5) Refer to a common auto switch (Best Pneumatics No 2), when an auto switch is built and used within the system.**

### **(6) When conformity to UL is required, the electric actuator and controller should be used with a UL1310 Class 2 power supply.**

## **19.2 Mounting**

## **Warning**

### **(1) Install and operate the product only after reading the Operation Manual carefully and understanding its contents.**

**Keep the manual in a safe place for future reference.**

### **(2) Tighten threads with the proper tightening torque.**

Tighten the screws to the recommended torque for mounting the product.

### **(3) Do not make any alterations to this product.**

Alterations made to this product may lead to a loss of durability and damage to the product, which can lead to human injury and damage to other equipment and machinery.

### **(4) When using an external guide, the guide axis should be parallel to the actuator axis.**

There will be damage/excessive wear on the lead screw if the external guide is not parallel.

### **(5) When an external guide is used, connect the moving parts of the actuator and the load in such a way that there is no interference at any point within the stroke.**

Do not scratch or dent the sliding parts of the actuator tube or piston rod etc., by striking them with other objects. Components are manufactured to precise tolerances, so the slightest deformation may cause faulty operation.

### **(6) Prevent the seizure of rotating parts (pins, etc.) by applying lubricating grease.**

### **(7) Do not use the product before verifying that the equipment can operate properly.**

After mounting or repair, connect the power supply to the product and perform appropriate functional inspections to check it is mounted properly.

### **(8) Cantilever**

When the actuator is operated at high speeds while it is fixed at one end and free at the other end (flange type, foot type, double clevis type, direct mount type), a bending moment may act on the actuator due to vibration generated at the stroke end, which can damage the actuator. In such a case, install a support bracket to suppress the vibration of the actuator body or reduce the speed so that the actuator does not vibrate. Use a support bracket also when moving the actuator body or when a long stroke actuator is mounted horizontally and fixed at one end.

**(9) When mounting the actuator or attaching to the work piece, do not apply strong impact or large moment.**

If an external force above the allowable moment is applied, it may cause looseness in the guide unit, an increase in sliding resistance or other problems.

**(10) Ensure sufficient space for maintenance activities.**

Allow sufficient space for maintenance and inspection.

### 19.3. Handling Precautions

#### **Warning**

**(1) Do not touch the motor while in operation.**

The surface temperature of the motor can increase to approx. 90°C to 100°C due to operating conditions. Energizing alone may also cause this temperature increase. Do not touch the motor when in operation as it may cause burns.

**(2) If abnormal heating, smoking or fire, etc., occurs in the product, immediately shut OFF the power supply.**

**(3) Immediately stop operation if abnormal operation noise or vibration occurs.**

If abnormal operation noise or vibration occurs, the product may have been mounted incorrectly. Unless operation of the product is stopped for inspection, the product can be seriously damaged.

**(4) Never touch the rotating part of the motor or moving part of the actuator while in operation.**

**(5) When installing, adjusting, inspecting or performing maintenance on the product, controller and related equipment, shut OFF the power supply to each of them. Then, lock it so that no one other than the person can turn the power on, or implement measures such as a safety plug.**

**(6) In the case of the actuator with a servo motor (24VDC), the "motor phase detection step" is done by turning ON "SVON" just after the controller power is turned ON. The "motor phase detection step" moves the table/rod for the distance of one screw-lead maximum. (The motor rotates in the reverse direction if the table hits an obstacle such as the end stop damper.) Take the "motor phase detection step" into consideration for the installation and operation of this actuator.**

#### **Caution**

**(1) Keep the controller and actuator combination as delivered for use.**

The product parameters are set before shipment. If the controller is combined with a different actuator, failure can result.

**(2) Check the product for the following points before operation.**

- a) Damage to power supply line and signal line
- b) Looseness of the connector to the power and signal lines
- c) Looseness of the actuator/cylinder and controller/driver mounting
- d) Abnormal operation
- e) Emergency stop of the whole system

**(3) When more than one person is performing work, decide on the procedures, signals, measures for emergency and how to start the operation after the measures taken. Also, designate a person to supervise work other than those performing work.**

**(4) Actual speed of the product will be changed by the workload.**

Before selecting a product, check the catalog for the instructions regarding selection and specifications.

**(5) Do not apply a load, impact or resistance, in addition to a transferred load during the "Return to Origin" operation.**

When performing return to origin by pushing force, additional force will cause displacement of the origin position since it is based on detected motor torque.

**(6) Do not remove the name plate.**

**(7) An operation test should be carried out using a low speed. Start operation using the predefined speed after confirming there are no problems.**

## [Grounding]

### Warning

- (1) Provide a good earth connection to the actuator.
- (2) The earth should be a dedicated earth connection. Class D dedicated grounding should be used. (Ground resistance 100Ω or less)
- (3) The earth cable length should be as short as possible.

## [Unpacking]

### Caution

- (1) Check that the received product is as ordered.  
If a different product is installed, other than that ordered, injury or damage can result.

## 19.4 Operating environment

### Warning

#### (1) Avoid use in the following environments.

1. Locations where a large amount of dust and cutting chips are airborne.
2. Locations where the ambient temperature is outside the range of the temperature specification (refer to specifications).
3. Locations where the ambient humidity is outside the range of the humidity specification (refer to specifications).
4. Locations where corrosive gas, flammable gas, seawater, water and steam are present.
5. Locations where strong magnetic or electric fields are generated.
6. Locations where direct vibration or impact is applied to the product.
7. Areas that are dusty, or are exposed to splashes of water and oil drops.
8. Areas exposed to direct sunlight (ultraviolet rays).
9. Environment at an altitude of 1000 meters or higher Heat dissipation and withstand voltage will decrease.  
Contact your SMC representative for details.

#### (2) Do not use in an environment where the product is directly exposed to liquid, such as cutting oils.

If cutting oils, coolant or oil mist contaminates the product, failure or increased sliding resistance can result.

#### (3) Install a protective cover when the product is used in an environment directly exposed to foreign matter such as dust, cutting chips and spatter.

Play or increased sliding resistance can result.

#### (4) Shade the sunlight in the place where the product is applied with direct sunshine.

#### (5) Shield the product if there is a heat source nearby.

When there is a heat source surrounding the product, the radiated heat from the heat source can increase the temperature of the product beyond the operating temperature range.

#### (6) Grease oil can be reduced due to the external environment and operating conditions. The lubrication performance may deteriorate and shorten the life of the product.

## [Storage]

### Warning

- (1) Do not store the product with direct contact to rain or water drops. Do not store the product where it is exposed to harmful gases or liquid.
- (2) Store in an area that is shaded from direct sunlight and has a temperature and humidity within the specified range (-10°C to 60°C and up to 85%. No condensation or freezing.)
- (3) Do not apply vibration and impact to the product during storage.

## 19.5 Maintenance Precautions

### Warning

**(1) Do not disassemble or repair the product.**

Fire or electric shock can result.

**(2) Before modifying or checking the wiring, the voltage should be checked with a tester 5 minutes after the power supply is turned OFF.**

Electric shock can result.

### Caution

**(1) Maintenance should be performed according to the procedure indicated in the Operating Manual.**

Incorrect handling can cause injury, damage or malfunction of equipment and machinery.

**(2) Removal of product**

When equipment is serviced, first confirm that measures are in place to prevent dropping of work pieces and run-away of equipment, etc, then cut the power supply to the system. When machinery is restarted, check that operation is normal with actuators in the proper positions.

**(3) When moving the electric actuator slider manually by hand, please disconnect the actuator cable.**

The electric actuator cannot be moved smoothly by the induced voltage of the motor goes to the controller when electric actuator slider is moved with the electric actuator connected with the controller. Moreover, the controller might break down by the induced voltage when moving the electric actuator slider at high frequency.

## [Lubrication]

### Caution

**(1) The product has been lubricated for life at the manufacturer's and does not require lubrication in service.**

Contact SMC if lubrication is to be applied.

## 19.6 Precautions for actuator with lock

### Warning

**(1) Do not use the lock as a safety lock or a control that requires a locking force.**

The lock used for the product with a lock is designed to prevent dropping of work pieces.

**(2) For vertical mounting, use the product with a lock.**

If the product is not equipped with a lock, the product will move and drop the work piece when the power is removed. If the actuator with lock is not used, preventive measures should be taken in the design of the equipment.

**(3) "Measures against drops" means preventing a work piece from dropping due to its weight when the product operation is stopped and the power supply is turned OFF.**

**(4) Do not apply an impact load or strong vibration while the lock is activated.**

If an external impact load or strong vibration is applied to the product, the lock will lose its holding force and damage to the sliding part of the lock or reduced lifetime can result. The same situations will happen when the lock slips due to a force over the thrust of the product, as this accelerates the wear to the lock.

**(5) Do not apply liquid or oil and grease to the lock or its surrounding.**

If liquid or oil and grease is applied to the sliding part of the lock, its holding force will reduce significantly.

**(6) Take measures against drops and check that safety is assured before mounting, adjustment and inspection of the product.**

If the lock is released with the product mounted vertically, a work piece can drop due to its weight.

**(7) When the actuator is operated manually (when “SVRE” signal is OFF), supply 24VDC to the [LK RLS] terminal of the power supply connector.**

If the product is operated without releasing the lock, wear of the lock sliding surface will be accelerated, causing a reduction in the holding force and the life of the locking mechanism.

**(8) Do not supply 24VDC power supply constantly to the [LK RLS].**

Only supply 24VDC power supply to the [LK RLS(Lock release)] terminal during normal operation. If power is supplied to the [LK RLS] terminal continuously, the lock will be released, and workpieces may be dropped at stop (EMG).

## 20. Controller and Peripheral Devices/Specific Product Precautions

### 20.1 Design and Selection

#### Warning

**(1) Use the specified voltage.**

Otherwise, malfunction and damage to the controller may result.

If the applied voltage is lower than the specified voltage, it is possible that the load cannot be moved due to an internal voltage drop. Check the operating voltage before use.

**(2) Do not operate beyond the specifications.**

Fire, malfunction or actuator damage can result. Check the specifications before use.

**(3) Install an emergency stop circuit.**

Install an emergency stop outside of the enclosure so that it can stop the system operation immediately and intercept the power supply.

**(4) In order to prevent danger and damage due to the breakdown and the malfunction of this product, which may occur at a certain probability, a backup system should be established in advance by giving a multiple-layered structure or a fail-safe design to the equipment, etc.**

**(5) If fire or personal injury is expected due to abnormal heat generation, ignition, smoking of the product, etc., cut OFF the power supply for this product and the system immediately.**

### 20.2 Handling Precautions

#### Warning

**(1) The inside of the controller and its connector should not be touched.**

It may cause an electric shock or damage to the controller.

**(2) Do not perform operation or setting of this equipment with wet hands.**

It may cause an electric shock.

**(3) A product that is damaged or missing any components should not be used.**

Electric shock, fire, and injury can result.

**(4) Use only the specified combination of controller and electric actuator.**

It may cause damage to the controller or the actuator.

**(5) Be careful not to be caught or hit by the workpiece while the actuator is moving.**

It may cause an injury.

**(6) Do not connect the power supply to the product until it is confirmed that the workpiece movement area is safe.**

The movement of the workpiece may cause an accident.

**(7) Do not touch the product when it is energized and for some time after power has been disconnected, as it can be very hot.**

It may cause burns due to the high temperature.

**(8) Check for voltage using a tester at least 5 minutes after power-OFF when performing installation, wiring and maintenance.**

Electric shock, fire, and injury can result.

**(9) Do not use the product in an area where it could be exposed to dust, metallic powder, machining chips, or splashes of water, oil or chemicals.**

A failure or malfunction can result.

**(10) Do not use the product in an area where a magnetic field is generated.**

It will cause failure or malfunction.

**(11) Do not install the product in an environment where flammable gas, explosive or corrosive gas, liquids or other substances are present.**

It could lead to fire, explosion and corrosion.

**(12) Avoid radiant heat from large heat sources such as direct sunlight or hot furnaces.**

It will cause failure of the controller or its peripheral devices.

**(13) Do not use the product in an environment subjected to cyclic temperature changes.**

It will cause failure of the controller or its peripheral devices.

**(14) Do not use in a location where surges are generated.**

When there are units that generate a large amount of surge around the product (for example solenoid type lifters, high frequency induction furnaces, motors, etc.), this may cause deterioration or damage to the product's internal circuit. Avoid surge generation and crossed lines.

**(15) Do not install the product in an environment subjected to vibration and impact.**

It will cause failure or malfunction.

**(16) If this product is used in conjunction with a relay or solenoid valve, use a type with a surge absorbing element built-in.**

## 20.3 Mounting

### Warning

**(1) The controller and its peripheral devices should be installed on a fire-proof material.**

Direct installation on or near a flammable material may cause fire.

**(2) Do not install this product in a location subject to vibration and impact.**

A failure and malfunction can result.

**(3) Take measure so that the operating temperature of this controller and its peripheral devices are within the range of the specifications. Also, this controller should be installed with 50mm or larger spaces between each side of it and the other structures or components.**

It may cause a malfunction of the controller and its peripheral devices and a fire.

**(4) Do not mount the controller and its peripheral devices near a large electromagnetic contactor or no-fuse breaker which generates vibration on the same panel. Mount them on different panels, or keep the controller and its peripheral devices away from such a vibration source.**

**(5) The controller and its peripheral devices should be installed on a flat surface.**

If the mounting surface is distorted or not flat, excessive force may be applied to the housing, etc. causing malfunction.

## 20.4 Wiring

### Warning

- (1) Do not damage the cable or apply a heavy object or pinch the cable. Avoid repeatedly bending or stretching the cable.**

It may cause an electric shock, fire, or breaking of wire.

- (2) Wire correctly.**

Incorrect wiring could damage the controller or its peripheral devices depending on the seriousness.

- (3) Do not perform wiring while the power is on.**

It can damage the controller or its peripheral devices could be damaged, causing malfunction.

- (4) Do not carry this product by holding its cables.**

It may cause an injury or damage to the product.

- (5) Do not route wires or cables together with power or high voltage cables.**

The wires to the controller or its peripheral devices can be interrupted with noise or induced surge voltage from power lines or high-voltage lines, causing malfunction.

Route the wires of the product separately from power or high voltage cables.

- (6) Verify the insulation of wiring.**

Insulation failure (interference with another circuit, poor insulation between terminals etc.) could introduce excessive voltage or current to the controller or its peripheral devices and damage them.

## 20.5 Power supply

### Caution

- (1) Use a power supply with low noise between lines and between power and ground.**

In cases where noise is high, use an isolation transformer.

- (2) The power supplies for the controller power and the I/O signal power should be separate, and both Power supplies should not be of the "in-rush current limiting type".**

If the power supply is of the "in-rush current limiting type", a voltage drop may occur during the acceleration of the actuator.

- (3) Take appropriate measures to prevent lightning surges. Ground the surge absorber for lightning separately from the ground connection for the controller and its peripheral devices.**

## 20.6 Grounding

### Warning

- (1) Ensure that the product is grounded to allow the noise tolerance of the controller.**

Otherwise it may cause an electric shock or fire.

- (2) A dedicated Ground connection must be used.**

Grounding should be to a D-class ground connection. (Ground resistance 100Ω or less)

- (3) The grounding point should be as near as possible to the controller to keep the cable length short.**

- (4) In the unlikely event that malfunction is caused by the ground connection, it may be disconnected.**



## 20.7 Maintenance

### Warning

#### (1) Perform maintenance checks periodically.

Confirm wiring and screws are not loose.  
Loose screws or wires may cause unexpected malfunction.

#### (2) Conduct an appropriate functional inspection and test after completing maintenance.

In case of any abnormalities (if the actuator does not move, etc.), stop the operation of the system.  
Otherwise, an unexpected malfunction may occur and it will become impossible to ensure safety.  
Give an emergency stop instruction to confirm safety.

#### (3) Do not disassemble, modify or repair this controller or the peripheral devices.

#### (4) Do not put anything conductive or flammable inside of the controller.

Fire or explosion can result.

#### (5) Do not perform an insulation resistance test or insulation withstand voltage test.

#### (6) Ensure sufficient space for maintenance.

Design the system to allow the required space for maintenance.

## 20.8. Specific Precautions for Battery-Less Absolute Encoder

### Warning

#### (1) Do not use in an environment where strong magnetic field is present.

A magnetic sensor is used in the encoder. Therefore, if the actuator motor is used in a strong magnetic field environment, malfunction or failure may occur.

The major failure is described below.

- Reduction of transporting ability (pushing force, speed)
- Damage to the actuator due to collision to the workpiece by positional displacement occurred.

Do not expose the actuator motor to a magnetic field with a magnetic flux density of 1 mT or more.

When installing an electric actuator or an air cylinder with an auto switch (ex. CDQ2 series) or electric actuators side by side, maintain 40 mm minimum around the motor.

Refer to the construction drawing of the actuator motor.

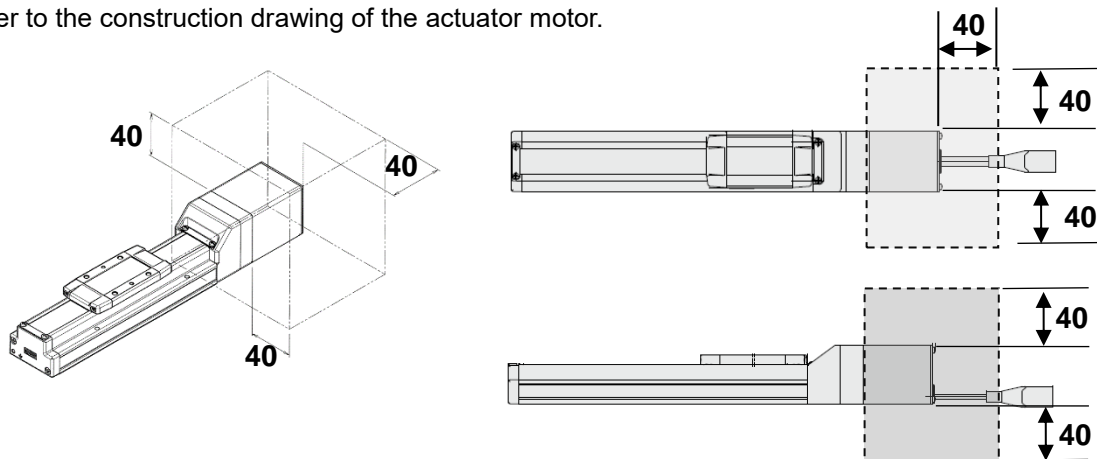

Air cylinder installation with an auto switch is forbidden in the shaded area.



**(2) Check whether there are any loose connections between the controller and actuator.**

If contact failure occurs with the motor powerwiring, the motor power will be insufficient, which reduces the holding force.

Because of this, the actuator moving part will fall downward in a vertical operation.

(In this operation, the lock function of the actuator with lock does not work).

The surge voltage generated by contact failure may damage the controller.

**(3) The ambient temperature of the controller should be lower than 55°C depending on the operating conditions of the actuator.**

For the LEY40 and LEYG40 series, if the vertical transfer load is greater than the weight listed below, the controller must be used at an ambient temperature of 40°C or less. Otherwise, damage may occur due to higher temperature of the controller.

LEY40□EA: 9 kg, LEY40□EB:19 kg, LEY40□EC:38 kg

LEYG40□EA:7 kg, LEYG40□EB:17 kg, LEYG40□EC:36 kg

**⚠Caution**

**(1) Supply power when the actuator is stationary.**

The controller acquires the absolute position data from the absolute encoder when power is applied.

Therefore, if the power is applied to the controller when the actuator is moving with an external force, the controller fails to acquire the absolute position data, which generates an alarm.

**(2) When the controller is used for the first time, perform the offset adjustment.**

Alarm “Absolute encoder ID Alarm error (code: 1-153)” will be generated when power is applied to the controller for the first time and/or when the actuator is replaced, therefore reset the alarm.

(Resetting the alarm registers the absolute encoder specific ID No. in the controller)

Turn the servo ON after resetting the alarm. Conducting a Return to Origin operation allows the use of the controller.

**(3) When a blank controller and actuator absolute encoder with battery are used, write the parameter for the actuator to the absolute encoder with battery before use.**

although the actuator type is identical, the actuator parameter in which the encoder and motor specifications are not identical are written, noise or vibration occurs during servo ON or operation.

If the parameter for the actuator with different specification is written, re-write the parameter for the actuator with the battery-less absolute encoder using JXC-BCW.

## 21. Troubleshooting

In case of any troubles, please consult the following table.

Consider replacing controller, if not of the causes on this table are applicable.

It is possible that this product may be damaged due to the operating conditions (applications). Please contact SMC to discuss appropriate measures.

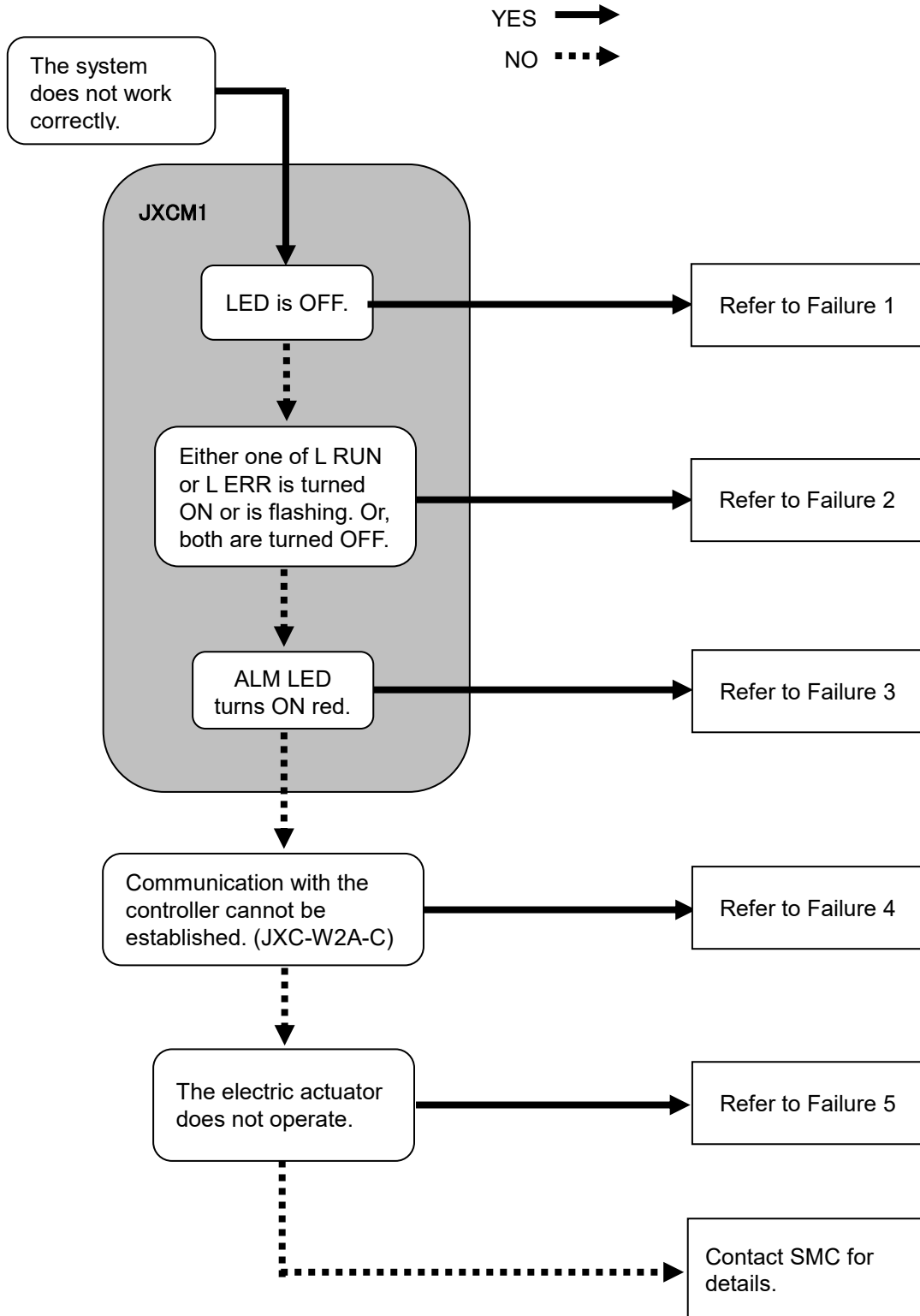

Problem No.	Problem	Possible causes	Investigation method and location of possible causes	Countermeasures
1	LED is OFF.	Power fault	Is the green LED on the controller ON?	Check the voltage and current supplied to the controller. ⇒ <b>5. External Connections</b> ⇒ <b>6. Details of Power Supply Plug</b>
		Incorrect wiring	Is the wiring connected correctly?	Check if the wiring is connected correctly or if there is broken wire or short-circuit by referring to this Operation Manual. Correct the wiring and check that the input/output of each signal is correct. Separate the power supply for the CN1 controller and the CN5 I/O signal power supply. ⇒ <b>5. External Connections</b> ⇒ <b>10. Memory map</b>
2	L RUN or L ERR is on/ flashing	CPU ALM	Are both the L RUN (green) and L ERR (red) LED ON?	It is possible that the CPU or surrounding circuits have failed, or the CPU is malfunctioning due to electrical noise. If the alarm is still generated when power is reapplied, please contact SMC.
		CC-Link communication error	What are the states of the L RUN (green) and L ERR (red) LED?	Take appropriate measures by referring to and following the controller operation manual. ⇒ <b>8. LED display</b> ⇒ <b>17. Alarm Detection for CC-Link Communication</b>
3	ALM: ON	Alarm generated	Check if the controller is in the alarm condition.	Refer to the controller operation manual, and take appropriate measures. Take appropriate measures based on the operation manual. ⇒ <b>16. Alarm for Motor Control</b>
4	Communication fault (JXC-W2)	The USB driver is not installed	Check that the USB driver for the conversion unit is installed.	Please install the USB driver of the communication unit. The USB driver's installation starts when the communication unit is connected with PC. Details of the installation procedure are shown in "Installation procedure of the JXC-W2 setting software".
		Incorrect COM port setting	Please confirm if the correct COM port is set to the ACT Controller.	The COM port allocated to the controller is different for different PC's. Check and confirm the COM port number with the controller connected to the PC. The COM port number can be checked using the Device Manager of the PC. For details of the COM port checking and setting methods refer to the "JXC-W2 Controller Configuration Software Installation Manual".
		Connection failure	Check the wiring	Please confirm motor controller = communications cable = USB cable = PC is connected. As example, cannot make the communication if the connector has been damaged. Please confirm the power supply of motor controller (JXC) has been turned ON. Communication cannot be established if the power supply is OFF. If the equipments (PLC and measurement hardware) except motor controller is connected with PC. (There is a possibility that the communication with other equipment interferes in PC.)

5	Does not operate at all.	Lock release error	When the unlock switch is turned ON or OFF there is an unlocking sound made.	If there is no sound of lock release, the lock brake may be broken. ⇒ If the problem persists, please contact SMC.
		External equipment failure	Check that the PLC connected to the controller operates correctly. Test operation of the controller on its own.	Check the operation by test run using the controller setting kit, etc. If the electric actuator is operated, a signal output from the PLC is suspected. Refer to the controller operation manual and take appropriate measures. ⇒ <b>10. Memory map</b>
		Unsuitable spec.	Check that the combination of the electric actuator and controller is correct? If a blank controller is used, check that the written data is identical to the actuator used.	Take appropriate measures according to this manual. ⇒ <b>3. Specifications</b> If a blank controller is used, write the data which is identical to the product number of the actuator used.
		Influence of a magnetic force	Check if there is equipment which generates the magnetic force, such as a magnet or electro-magnetic coil around the actuator.	The equipment, which generates the magnetic force, should be kept away from the motor. For example, keep 40 mm minimum distance from the cylinder with auto switch.
		Stop command	If it is not energized, the servo will be OFF and does not operate. Check if a voltage of 24 VDC is applied to the EMG terminal.	Apply 24 VDC to the EMG terminal.
	Operation stops intermittently	Incorrect wiring	Is the wiring connected correctly?	Check if the wiring is connected correctly or if there is broken wire or short-circuit by referring to this Operation Manual. Correct the wiring and check that the input/output of each signal is correct. Separate the power supply for the CN1 controller and the CN5 I/O signal power supply. ⇒ <b>5. External Connections</b> ⇒ <b>10. Memory map</b>
		Electric noise	Check that the Grounding is connected correctly? Are power cables for other equipment and controller cables bundled together?	Connect to Ground correctly. Avoid bundling the cables with power cables of other equipment. Refer to the controller operation manual and take appropriate measures. ⇒ <b>3.4 Mounting</b>
		Incorrect parameters	Check that the parameter values are correct.	Check the combination of the electric actuator and controller. Modify the parameters accordingly and check the operation. ⇒ <b>11. Settings and Data Entry</b>
		Voltage drop	Check for a temporary voltage drop in the power supply? (If there is a temporary voltage drop in the power supply, the "EMG" signal from the PWR connector will turn OFF so the actuator will stop. However, this stop will be released when the voltage recovers.)	There is a possibility of a momentary voltage drop because the capacity of the power supply is insufficient, or if the power supply is "inrush-current control" type. If necessary, replace the power supply. ⇒ <b>3. Specifications</b>

Operation stops intermittently	Failure of pushing operation.	Check that "INP" turns ON during a pushing operation. (If completion of the pushing operation is detected by "INP", the PLC cannot confirm completion)	Check "INP" signal before the energy saving mode is turned ON. ⇒ <b><u>10. Memory map</u></b>
	Unsuitable spec.	Check that the combination of the electric actuator and controller is correct? If a blank controller is used, check that the written data is identical to the actuator used.	Take appropriate measures according to this manual. ⇒ <b><u>3. Specifications</u></b> If a blank controller is used, write the data which is identical to the product number of the actuator used.
	Influence of a magnetic force	Check if there is equipment which generates the magnetic force, such as a magnet or electro-magnetic coil around the actuator.	The equipment, which generates the magnetic force, should be kept away from the motor. For example, keep 40 mm minimum distance from the cylinder with auto switch.
	Signal timing	Check the timing of the signal from the PLC to the controller.	Set the interval time between signals to more than twice the communication cycle time, when the signals are to be continuously input, because PLC processing delays and controller scanning delays can occur. ⇒ <b><u>12.4 Controller input signal response time</u></b>
	SVON time	Check if the electric actuator is operated when the SVRE output is turned on after the SVON input is turned on.	When power is applied, it may take up to 10 seconds (max. 20 sec.) from SVON input to SVRE output depending on the electric actuator position. Command operation after SVRE output is turned ON.
	Alarm condition	Is controller alarm generated?	Refer to the controller operation manual, and take appropriate measures. Take appropriate measures based on the operation manual. ⇒ <b><u>16. Alarm for Motor Control</u></b> ⇒ <b><u>17. Alarm Detection for CC-Link</u></b>
The actuator does not move to the correct position. Operation stops intermittently	Incorrect origin position	If it is a pushing operation, repeat return to origin operations several times to check if the actuator returns to the origin correctly.	Perform the return to origin position operation several times to check the origin position. Take measures to make the actuator operate normally (remove foreign matter that interferes with the actuator movement, etc.)
	Incorrect parameters	Check that the parameter values are appropriate and the program is correct.	Check the max. speed, acceleration speed, and deceleration speed of the electric actuator and be sure to input the correct parameters. ⇒ <b><u>11. Settings and Data Entry</u></b>
	Unsuitable specification	Check that the combination of the electric actuator and controller is correct? If a blank controller is used, check that the written data is identical to the actuator used.	Take appropriate measures according to this manual. ⇒ <b><u>3. Specifications</u></b> If a blank controller is used, write the data which is identical to the product number of the actuator used.

The actuator does not move correctly.	Incorrect wiring	Is the wiring connected correctly?	Check if the wiring is connected correctly or if there is broken wire or short-circuit by referring to this Operation Manual. Correct the wiring and check that the input/output of each signal is correct. Separate the power supply for the CN1 controller and the CN5 I/O signal power supply. ⇒ <b><u>5. External Connections</u></b> ⇒ <b><u>10. Memory map</u></b>
	Unsuitable specification	Check that the combination of the electric actuator and controller is correct? If a blank controller is used, check that the written data is identical to the actuator used.	Take appropriate measures according to this manual. ⇒ <b><u>3. Specifications</u></b> If a blank controller is used, write the data which is identical to the product number of the actuator used.
	Signal timing	Check the timing of the signal from the PLC to the controller.	Set the interval time between signals to more than twice the communication cycle time, when the signals are to be continuously input, because PLC processing delays and controller scanning delays can occur. ⇒ <b><u>12.4 Controller input signal response time</u></b>
	Data not stored correctly	Check whether data (step data, parameter) is written correctly.	One of the following actions occurred during data writing (while the power supply LED (green) was on). • Turn off the controller input power supply • Disconnected/ connected cables. Input correct data (step data, parameter) again and confirm operation. ⇒ <b><u>3.2 Parts Description</u></b> ⇒ <b><u>11. Settings and Data Entry</u></b>
	Influence of a magnetic force	Check if there is equipment which generates the magnetic force, such as a magnet or electro-magnetic coil around the actuator.	The equipment, which generates the magnetic force, should be kept away from the motor. For example, keep 40 mm minimum distance from the cylinder with auto switch.
The actuator does not move correctly.	Incorrect parameters	Check that the parameter values are correct.	Check the max. speed and acceleration speed of the electric actuator and be sure to input the correct parameters. ⇒ <b><u>11. Settings and Data Entry</u></b>
	Operation pattern is not suitable.	Check if a trapezoidal acceleration/deceleration is programmed for the actuator operation.	Check the max. speed and acceleration speed of the electric actuator and be sure to input the correct parameters. ⇒ <b><u>11. Settings and Data Entry</u></b>
	Unsuitable specification	Check that the combination of the electric actuator and controller is correct? If a blank controller is used, check that the written data is identical to the actuator used.	Take appropriate measures according to this manual. ⇒ <b><u>3. Specifications</u></b> If a blank controller is used, write the data which is identical to the product number of the actuator used.
	Influence of a magnetic force	Check if there is equipment which generates the magnetic force, such as a magnet or electro-magnetic coil around the actuator.	The equipment, which generates the magnetic force, should be kept away from the motor. For example, keep 40 mm minimum distance from the cylinder with auto switch.
Speed not achieved	Incorrect parameters	Check that the parameter values are correct.	Check the max. speed and acceleration speed of the electric actuator and be sure to input the correct parameters. ⇒ <b><u>11. Settings and Data Entry</u></b>
	Operation pattern is not suitable.	Check if a trapezoidal acceleration/deceleration is programmed for the actuator operation.	Check the max. speed and acceleration speed of the electric actuator and be sure to input the correct parameters. ⇒ <b><u>11. Settings and Data Entry</u></b>
	Unsuitable specification	Check that the combination of the electric actuator and controller is correct? If a blank controller is used, check that the written data is identical to the actuator used.	Take appropriate measures according to this manual. ⇒ <b><u>3. Specifications</u></b> If a blank controller is used, write the data which is identical to the product number of the actuator used.
	Influence of a magnetic force	Check if there is equipment which generates the magnetic force, such as a magnet or electro-magnetic coil around the actuator.	The equipment, which generates the magnetic force, should be kept away from the motor. For example, keep 40 mm minimum distance from the cylinder with auto switch.

	Voltage drop	<p>Check for a temporary voltage drop in the power supply?</p> <p>(If there is a temporary voltage drop in the power supply, the EMG terminal of CN1 power connector will turn OFF so the actuator will stop. However, this stop will be released when the voltage recovers.)</p>	<p>There is a possibility of a momentary voltage drop because the capacity of the power supply is insufficient, or if the power supply is "inrush-current control" type.</p> <p>If necessary, replace the power supply.</p> <p>⇒ <b><u>3. Specifications</u></b></p>
--	--------------	---	--

## 22. Memory map list

The memory map according to the mode is shown below. Please refer to “10. Memory map” for details of each signal.

### ●Single numerical data instructions (1 Stations occupied) [Remote IO]

PLC memory address	Signal name	PLC memory address	Signal name
Rx		Ry	
00	OUT0	00	IN0
01	OUT1	01	IN1
02	OUT2	02	IN2
03	OUT3	03	IN3
04	OUT4	04	IN4
05	OUT5	05	IN5
06	—	06	—
07	—	07	—
08	BUSY	08	HOLD
09	SVRE	09	SVON
0A	SETON	0A	DRIVE
0B	INP	0B	RESET
0C	AREA	0C	SETUP
0D	WAREA	0D	JOG(-)
0E	ESTOP	0E	JOG(+)
0F	ALARM	0F	FLGTH
1A to 10	CC-Link system area	1F to 10	CC-Link system area
1B	Remote station READY		
1F to 1C	CC-Link system area		

### ●Single numerical data instructions (1 Stations occupied) [Remote register]

PLC memory address		RWr Data name	PLC memory address		RWw Data name	
RWr	bit		RWw	bit		
0	0	Return of Occupied number of	0	0	Setting read numerical data	
	1	Return of Occupied number of		1	(No used)	
	2	Sending		2	Reset flag	
	3	Sending completed		3	Restart flag	
	4	READY		4	Movement MOD	
	5	ALARM flag		5	Speed	
	6	Initial		6	Position	
	7	Return of the read		7	Acceleration	
	8	(No used)		8	Deceleration	
	9			9	Pushing force	
	A			A	Trigger LV	
	B			B	Pushing speed	
	C			C	Moving force	
	D	Data editing error		D	Area 1	
	E	Parameter anomaly		E	Area 2	
F	The abnormal station	F	In position			
1	F to 0	Current position	0	Start flag		
			7 to 1	(No used)		
			F to 8	Movement MOD		
2	F to 0	2	F to 0	Numerical data instructions data (2 word data) *1	Numerical data instructions data (1 word data) *2	
3	F to 0	Current position	3	F to 0	(No used) *2	

\*1) RWw0, bit4 to F: Setting numerical data in the case of "Position" or "Area 1" or "Area 2".

\*2) RWw0, bit4 to F: Setting numerical data in the case of "Speed" or "Acceleration" or "Deceleration" or "Pushing force" or "Trigger LV" or "Pushing speed" or "Moving force" or "In position".



●Half numerical data instructions (2 Stations occupied) [Remote IO]

PLC memory		Signal name	PLC memory	
Rx	Ry		Signal name	
00	OUT0	00	IN0	
01	OUT1	01	IN1	
02	OUT2	02	IN2	
03	OUT3	03	IN3	
04	OUT4	04	IN4	
05	OUT5	05	IN5	
06	—	06	—	
07	—	07	—	
08	BUSY	08	HOLD	
09	SVRE	09	SVON	
0A	SETON	0A	DRIVE	
0B	INP	0B	RESET	
0C	AREA	0C	SETUP	
0D	WAREA	0D	JOG(-)	
0E	ESTOP	0E	JOG(+)	
0F	ALARM	0F	FLGTH	
10 to 2F	(No used)	10 to 2F	(No used)	
3A to 30	CC-Link system area	3F to 30	CC-Link system area	
3B	Remote station READY			
3F to 3C	CC-Link system area			

●Half numerical data instructions (2 Stations occupied) [Remote register]

PLC memory address		RWr Data name		PLC memory address		RWw Data name	
RWr	bit	Numerical data instructions operation	Data editing	RWw	bit	Numerical data instructions operation	Data editing
0	0	Return of Occupied number of		0	0	Setting read numerical data	
	1	Return of Occupied number of			1	Setting parameter rewriting	
	2	Sending			2	Reset flag	
	3	Sending completed			3	Restart flag	
	4	READY			4	Movement	Start flag
	5	ALARM flag			5	Speed	(No used)
	6	Initial			6	Position	
	7	Return of the read numerical			7	Acceleration	
	8	Return of parameter rewriting			8	Deceleration	
	9	(No used)			9	Pushing	
	A				A	Trigger LV	
	B				B	Pushing	
	C				C	(No used)	
	D	Data editing error receiving			D		
	E	Parameter anomaly detection			E		
F	The abnormal station detection		F				
1	F to 0	Current position		1	0	Start flag	Sub Function
					7 to 1	(No used)	
				F to 8	Movement		
2	F to 0			2	F to 0	Speed	Address
3	F to 0	Current speed	Sub Function	3	F to 0	Target position	Address
4	F to 0	Current Force	Address	4	F to 0	Acceleration (Pushing force)	DATA(H)
5	F to 0	Target position	Address (always 0)	5	F to 0		DATA(L)

6	F to 0		DATA(H)	6	F to 0	Deceleration (Trigger LV)	Occupation area
7	7 to 0 F to 8	Alarm 1 Alarm 2	DATA(L)	7	F to 0	Pushing speed	

● Full numerical data instructions (4 Stations occupied) [Remote IO]

PLC memory	Signal name	PLC memory	Signal name
Rx		Ry	
00	OUT0	00	IN0
01	OUT1	01	IN1
02	OUT2	02	IN2
03	OUT3	03	IN3
04	OUT4	04	IN4
05	OUT5	05	IN5
06	—	06	—
07	—	07	—
08	BUSY	08	HOLD
09	SVRE	09	SVON
0A	SETON	0A	DRIVE
0B	INP	0B	RESET
0C	AREA	0C	SETUP
0D	WAREA	0D	JOG(-)
0E	ESTOP	0E	JOG(+)
0F	ALARM	0F	FLGTH
10 to 6F	(No used)	10 to 6F	(No used)
7A to 70	CC-Link system	7F to 70	CC-Link system area
7B	Remote station		
7F to 7C	CC-Link system		

●Full numerical data instructions (4 Stations occupied) [Remote register]

PLC memory address		RWr Data name		PLC memory address		RWw Data name	
RWr	bit	Numerical data instructions operation	Data editing	RWw	bit	Numerical data instructions operation	Data editing
0	0	Return of Occupied number of		0	0	Setting read numerical data	
	1	Return of Occupied number of			1	Setting parameter rewriting	
	2	Sending			2	Reset flag	
	3	Sending completed			3	Restart flag	
	4	READY			4	Movement	Start flag
	5	ALARM flag			5	Speed	(No used)
	6	Initial			6	Position	
	7	Return of the read numerical data			7	Acceleration	
	8	Return of parameter rewriting			8	Deceleration	
	9	(No used)			9	Pushing force	
	A				A	Trigger LV	
	B				B	Pushing	
	C				C	Moving force	
	D	Data editing error receiving			D	Area 1	
	E	Parameter anomaly detection			E	Area 2	
	F	The abnormal station detection			F	In position	
1	F to 0	Current position		1	0	Start flag	Sub Function
					7 to 1	(No used)	
					F to 8	Movement	
2	F to 0			2	F to 0	Speed	Address
3	F to 0	Current speed		3	F to 0	Target position	Address (always 0)
4	F to 0	Current Force		4	F to 0		DATA(H)
5	F to 0	Target position		5	F to 0	Acceleration	DATA(L)
6	F to 0			6	F to 0	Deceleration	
7	7 to 0	Alarm 1		7	F to 0	Pushing force	Occupation area
	F to 8	Alarm 2					
8	7 to 0	Alarm 3		8	F to 0	Trigger LV	
	F to 8	Alarm 4					
9	F to 0	Occupation area	Sub Function	9	F to 0	Pushing	
10	F to 0		Address	10	F to 0	Moving force	
11	F to 0		Address	11	F to 0	Area 1	
12	F to 0		DATA(H)	12	F to 0		
13	F to 0		DATA(L)	13	F to 0	Area 2	
14	F to 0		Occupation area	14	F to 0		
15	F to 0		Occupation area	15	F to 0		In position

## 23. Handling Remote Registers

There are 1-bit data, 1-byte data, 1-word data, or 2-word data assigned to the remote registers (RWr and RWw), depending on the data content.

### 23.1 Relationship of bit data, byte data, and word data

The following describes the relationship of each bit data, byte data, and word data for the JXCM1.

- 1-bit data

This indicates the OFF state (0) and ON state (1) by using one of the two types of data, "0" or "1".

It is used to specify signal ON / OFF outputs such as RWr0,bit3: Sending completed, as well as signal input instructions such as the RWw0,bit0: Read numerical data flag.

- 1-byte data

A group of eight 1-bit data items.

This indicates 0 to 255 data as an 8-digit binary number.

It is used to output an alarm code such as RWr7: Alarm.

- 1-word data

A group of 16 1-bit data or two 1-byte data.

This indicates the ON/OFF state of 16 types of signals or 0 to 65,535 data as a 16-digit binary number.

It is used to output numerical data by using RWr3: Current speed, etc. as well as input numerical data by using RWw2: Speed, etc.

- 2-word data

A group of two 1-word data.

This indicates 0 to 2,147,483,647 data as a 32 - digit binary number or -2,147,483,647 to -1 data as a complement to 2.

It is used to output numerical data by using RWr1 - RWr2: Current position, etc. or input numerical data by using RWw3 - RWw4: Target position, etc.

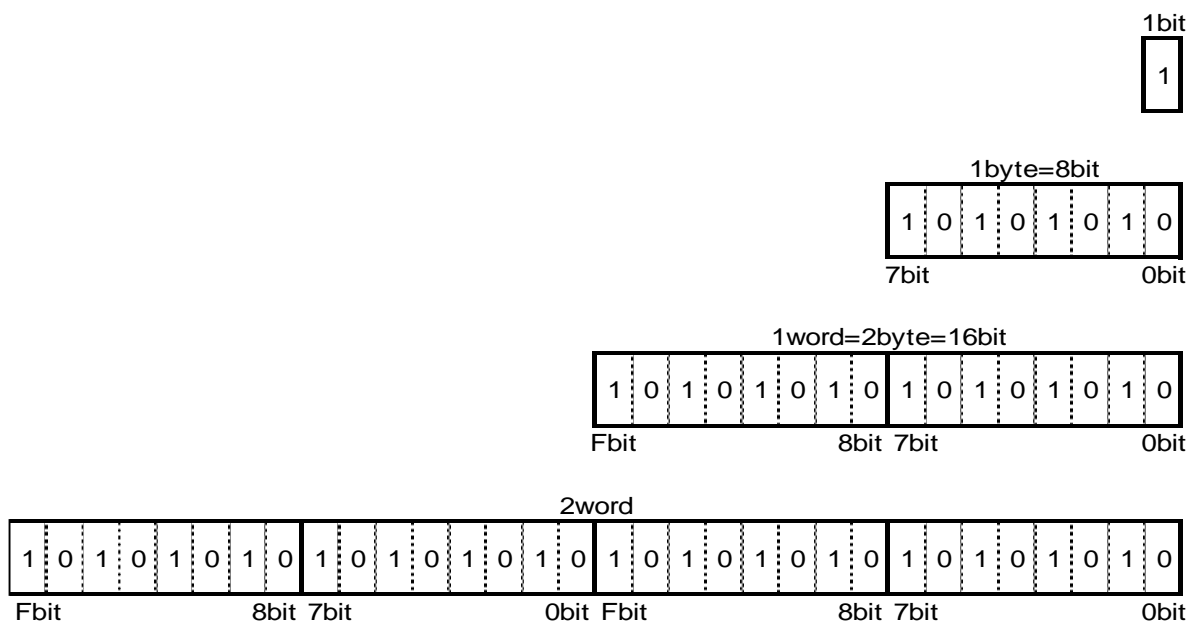

## 23.2 Relationship of binary (BIN), decimal (OCT), and hexadecimal (HEX) numbers

The following describes the relationship of binary (BIN), decimal (OCT), and hexadecimal (HEX) numbers.

E.g.) 1 byte

Binary (BIN)								Decimal (OCT)	Hexadecimal (HEX)
0	0	0	0	0	0	0	0	0	0
0	0	0	0	0	0	0	1	1	1
0	0	0	0	0	0	1	0	2	2
0	0	0	0	0	0	1	1	3	3
0	0	0	0	0	1	0	0	4	4
0	0	0	0	0	1	0	1	5	5
0	0	0	0	0	1	1	0	6	6
0	0	0	0	0	1	1	1	7	7
0	0	0	0	1	0	0	0	8	8
0	0	0	0	1	0	0	1	9	9
0	0	0	0	1	0	1	0	10	A
0	0	0	0	1	0	1	1	11	B
0	0	0	0	1	1	0	0	12	C
0	0	0	0	1	1	0	1	13	D
0	0	0	0	1	1	1	0	14	E
0	0	0	0	1	1	1	1	15	F
0	0	0	1	0	0	0	0	16	10
0	0	0	1	0	0	0	1	17	11
}								}	}
0	0	0	1	1	1	1	0	30	1E
0	0	0	1	1	1	1	1	31	1F
0	0	1	0	0	0	0	0	32	20
0	0	1	0	0	0	0	1	33	21
}								}	}
0	0	1	1	1	1	1	0	62	3E
0	0	1	1	1	1	1	1	63	3F
0	1	0	0	0	0	0	0	64	40
0	1	0	0	0	0	0	1	65	41
}								}	}
0	1	1	1	1	1	1	0	126	7E
0	1	1	1	1	1	1	1	127	7F
1	0	0	0	0	0	0	0	128	80
1	0	0	0	0	0	0	1	129	81
}								}	}
1	1	1	1	1	1	1	0	254	FE
1	1	1	1	1	1	1	1	255	FF



## 24. Definitions and terminology

The major terminology used in this Operation Manual is stated below.

	Term	Definition
<b>C</b>	CC-Link	It is a standard of the field bus that Mitsubishi Electric Corporation etc. promote. The share in the Asian area and Japan is high and CC-Link is used mainly in a large number of companies.
	Communication speed	It is a speed at which data is sent and received in the field bus etc. It depends on PLC etc., and the unit uses bps (bit per second).
<b>F</b>	Field bus	It is a standard to perform the communication of signal of Spot apparatus (measuring instrument, operation device) which operates in factories and PLC by the digital signal.
<b>N</b>	Number of stations	It is the total of the occupation station of all slaves station connected in CC-Link.
<b>O</b>	Occupied number of stations	Number of the stations on the network which one slave station uses. It is possible to set from Station 1 to Station 4 according to the number of the data.
<b>P</b>	PLC	Abbreviation of Programmable Logic Controller. It is a controller which sequential control by programs of the Boolean operation, the order operation, and the arithmetic operation, etc.
<b>R</b>	Remote device station	It is the slave station that can use bit data and word data.
	Remote IO	It is a memory area that treats the bit data.
	Remote register	It is a memory area that treats the word data.
	RWr	It is a remote register region of the input side which the master station receives the word data from the slave station.
	RWw	It is a remote register region of the output side which the master station sends the word data from the slave station.
	Rx	It is a remote I/O region of the input side which the master station receives the bit data from the slave station.
	Ry	It is a remote I/O region of the output side which the master station sends the bit data from the slave station.
<b>S</b>	Station No.	It is 0 of the master station and numbers from 1 to 64 to assign to the slave station on CC-Link. The slave station is necessary to assign it not to repeat in consideration of the number of the occupation station.
	Station type	It is a generic name of the slave station. By usable data (bit data and word data), there is a type of the remote I/O station, the remote device station and the intelligent device station.
<b>U</b>	Upper level device	Controller setting kit, Teaching box, PLC

### Trademark

The company name, system name, and product name described in this document are registered trademarks of each individual company. In this document TM and (R) are not specified.

Revision history

No. JXC~~※~~-OMX0009  
November 2020 First edition

## SMC Corporation

4-14-1, Sotokanda, Chiyoda-ku, Tokyo 101-0021 JAPAN  
Tel: + 81 3 5207 8249 Fax: +81 3 5298 5362  
URL <https://www.smcworld.com>

---

Note: Specifications are subject to change without prior notice and any obligation on the part of the manufacturer.  
© 2020 SMC Corporation All Rights Reserved

