



Operation Manual

PRODUCT NAME

Air cylinder

MODEL / Series / Product Number

C * G1 * N * — * Z

C * G1 * N * — * Z—XC85

C * G1 * N * — * Z—X446

SMC Corporation

Contents

Safety Instructions	P2
1. Specifications	P4
1-1. Specifications	
2. Installation and Handling	P4
2-1. Air supply	
2-2. Design	
2-3. Mounting and Installation	
2-4. Environment	
2-5. Speed control	
2-6. Allowable kinetic energy	
2-7. Control of direction	
2-8. Auto switches	
3. Maintenance	P19
3-1. Checks	
3-2. Replacement of seals	
3-3. Consumable parts	
3-4. Troubleshooting	
4. Made to order product (XC85, X446)	P27
4-1. Food Machinery Grease Specification	
4-2. PTFE Grease Specification	
5. Basic Circuit for Cylinder Operation	P28
6. Construction	P29



Safety Instructions

These safety instructions are intended to prevent hazardous situations and/or equipment damage. These instructions indicate the level of potential hazard with the labels of "Caution," "Warning" or "Danger." They are all important notes for safety and must be followed in addition to International Standards (ISO/IEC)^{*1)}, and other safety regulations.

*1) ISO 4414: Pneumatic fluid power -- General rules relating to systems.

ISO 4413: Hydraulic fluid power -- General rules relating to systems.

IEC 60204-1: Safety of machinery -- Electrical equipment of machines .(Part 1: General requirements)

ISO 10218-1992: Manipulating industrial robots -Safety.

etc.



Caution

Caution indicates a hazard with a low level of risk which, if not avoided, could result in minor or moderate injury.



Warning

Warning indicates a hazard with a medium level of risk which, if not avoided, could result in death or serious injury.



Danger

Danger indicates a hazard with a high level of risk which, if not avoided, will result in death or serious injury.

Warning

1. The compatibility of the product is the responsibility of the person who designs the equipment or decides its specifications.

Since the product specified here is used under various operating conditions, its compatibility with specific equipment must be decided by the person who designs the equipment or decides its specifications based on necessary analysis and test results.

The expected performance and safety assurance of the equipment will be the responsibility of the person who has determined its compatibility with the product.

This person should also continuously review all specifications of the product referring to its latest catalog information, with a view to giving due consideration to any possibility of equipment failure when configuring the equipment.

2. Only personnel with appropriate training should operate machinery and equipment.

The product specified here may become unsafe if handled incorrectly.

The assembly, operation and maintenance of machines or equipment including our products must be performed by an operator who is appropriately trained and experienced.

3. Do not service or attempt to remove product and machinery/equipment until safety is confirmed.

1. The inspection and maintenance of machinery/equipment should only be performed after measures to prevent falling or runaway of the driven objects have been confirmed.

2. When the product is to be removed, confirm that the safety measures as mentioned above are implemented and the power from any appropriate source is cut, and read and understand the specific product precautions of all relevant products carefully.

3. Before machinery/equipment is restarted, take measures to prevent unexpected operation and malfunction.

4. Contact SMC beforehand and take special consideration of safety measures if the product is to be used in any of the following conditions.

1. Conditions and environments outside of the given specifications, or use outdoors or in a place exposed to direct sunlight.

2. Installation on equipment in conjunction with atomic energy, railways, air navigation, space, shipping, vehicles, military, medical treatment, combustion and recreation, or equipment in contact with food and beverages, emergency stop circuits, clutch and brake circuits in press applications, safety equipment or other applications unsuitable for the standard specifications described in the product catalog.

3. An application which could have negative effects on people, property, or animals requiring special safety analysis.

4. Use in an interlock circuit, which requires the provision of double interlock for possible failure by using a mechanical protective function, and periodical checks to confirm proper operation.



Safety Instructions

Caution

1. The product is provided for use in manufacturing industries.

The product herein described is basically provided for peaceful use in manufacturing industries.

If considering using the product in other industries, consult SMC beforehand and exchange specifications or a contract if necessary.

If anything is unclear, contact your nearest sales branch.

Limited warranty and Disclaimer/Compliance Requirements

The product used is subject to the following “Limited warranty and Disclaimer” and “Compliance Requirements”.

Read and accept them before using the product.

Limited warranty and Disclaimer

1. The warranty period of the product is 1 year in service or 1.5 years after the product is delivered, whichever is first.*2)

Also, the product may have specified durability, running distance or replacement parts. Please consult your nearest sales branch.

2. For any failure or damage reported within the warranty period which is clearly our responsibility, a replacement product or necessary parts will be provided.

This limited warranty applies only to our product independently, and not to any other damage incurred due to the failure of the product.

3. Prior to using SMC products, please read and understand the warranty terms and disclaimers noted in the specified catalog for the particular products.

***2) Vacuum pads are excluded from this 1 year warranty.**

A vacuum pad is a consumable part, so it is warranted for a year after it is delivered.

Also, even within the warranty period, the wear of a product due to the use of the vacuum pad or failure due to the deterioration of rubber material are not covered by the limited warranty.

Compliance Requirements

1. The use of SMC products with production equipment for the manufacture of weapons of mass destruction (WMD) or any other weapon is strictly prohibited.

2. The exports of SMC products or technology from one country to another are governed by the relevant security laws and regulations of the countries involved in the transaction. Prior to the shipment of a SMC product to another country, assure that all local rules governing that export are known and followed.

1. Specifications

1-1 Specifications

Fluid	Air	
Proof pressure	1.5MPa	
Max. operating pressure	1.0MPa	
Min. operating pressure	0.05MPa	
Ambient and fluid temperature	-10 to +70°C. -10 to +60°C with built-in magnet (No freezing)	
Lubrication	Not required (non-lube)	
Stroke length tolerance	to 200st $^{+1.4}_0$ mm(ϕ 20) to 300st $^{+1.4}_0$ mm(ϕ 25 to ϕ 100)	
Cushion	Rubber bumper	
Piston speed	ϕ 20 to ϕ 63	50 to 1000mm/sec
	ϕ 80, ϕ 100	50 to 700mm/sec
Action	Double acting	

Use the actuator with allowable kinetic energy or less.
(Refer to 2-6. Allowable kinetic energy (Page 10))

Warning

- **Confirm the specifications.**

The product is designed only for use in industrial compressed air systems. Do not operate at pressures, temperatures or kinetic energy beyond the range of specifications, as this can cause damage to cylinder or malfunction.

(Refer to the specifications.)

Contact SMC in advance for non-industrial uses, or if using with a fluid other than compressed air.

2. Installation and Handling

2-1. Air supply

The compressed air supplied to the cylinder should be filtered by SMC AF series air filter and regulated to the specified set pressure by SMC AR series regulator.

Warning

- **Use clean air.**

Do not use compressed air which contains chemicals, synthetic oils containing organic solvents, salts or corrosive gases, etc., as this can cause cylinder damage or malfunction.

Caution

- **Install an air filter.**

Install an air filter upstream near the valve. Select an air filter with a filtration size of 5 μ m or smaller.

- **Therefore, take appropriate measures to ensure good air quality, such as providing an after cooler, air dryer, or water separator.**

Compressed air that contains a large amount of drainage can cause malfunction of pneumatic equipment such as valves. Therefore, take appropriate measures to ensure air quality, such as providing an after cooler, air dryer, or water separator.

- **Ensure that the fluid and ambient temperature are within the specified range.**

When operating at temperatures below 5°C, water in the circuit may freeze and cause breakage of seals or malfunction. Corrective measures should be taken to prevent freezing.

For compressed air quality, refer to Best Pneumatics No.5.

- **Lubrication of non-lubricating cylinder**

The product is a non-lube type and should be used without lubrication. If it is necessary to lubricate, install the lubricator in the circuit and use Class 1 turbine oil (with no additive) ISO VG32. Once lubricant is used in the system, lubrication must be continued because the original lubricant applied during manufacturing will be washed away.

2-2. Design

The compatibility of the product is the responsibility of the person who designs the equipment or decides its specifications.

Warning

- **There is a possibility of dangerous sudden action by air cylinders if sliding parts of machinery are twisted due to external forces, etc.**

In such cases, injury may occur, such as hands or feet getting caught in the machinery, or damage to the machinery itself may occur. Design the machinery to avoid such dangers.

- **A protective cover is recommended to minimize the risk of personal injury.**

If the moving portion of the product will pose a hazard to humans or will damage machinery or equipment, provide a construction that prevents direct contact with those areas.

- **Securely tighten all stationary parts and connected parts so that they will not become loose.**

Do not use the product where operation frequency is high or the product is exposed to vibration.

- **Design the system so that it will not apply an external force over the maximum force to the product.**

The product can break, causing a risk of injury or damage to equipment.

- **The product generates a large force. Install on a sufficiently rigid mounting base, taking this force into consideration.**

There is a risk of injury or damage to equipment.

- **Consider the possibility of a reduction in the circuit air pressure caused by a power failure.**

When a cylinder is used in a clamping mechanism, the work piece may come off due to a decrease in clamping force because of a decrease in the circuit pressure caused by a power failure, etc. Therefore, safety equipment should be installed to prevent damage to machinery and injury. Suspension equipment and lifting devices also require measures to prevent dropping.

- **Consider a possible loss of power source.**

Measures should be taken to prevent injury and equipment damage in the event that there is a loss of power to equipment controlled by air pressure, electricity or hydraulics, etc.

- **Consider the behavior of the rotary actuator in the event of an emergency stop.**

Devise a safety system so that if a person engages the emergency stop, or if a safety device is tripped during a system malfunction such as a power outage, the movement of the cylinder will not cause a hazard to humans or damage the equipment.

- **Consider the action when operation is restarted after an emergency stop or abnormal stop.**

Design the machinery so that injury or equipment damage will not occur upon restart of operation. When the cylinder has to be reset at the starting position, install manual safety equipment.

- **Intermediate stop**

It is difficult for this product to make a piston stop at the required intermediate position accurately and precisely using a 3 position closed center type directional control valve, due to the compressibility of air. Furthermore, since valves and cylinders are not guaranteed for zero air leakage, it may not be possible to hold a stopped position for extended periods of time. Contact SMC if it is necessary to hold the stopped position for extended periods of time.

Caution

- **Avoid having a large gap between the clevis and mating bushing, as this exposes the pin to a bending load.**
- **Do not touch the cylinder during high speed and high frequency operation of the cylinder.**

When the cylinder is operating at a high speed and high frequency, the cylinder tube surface temperature increases, and may cause a burn.

- **Do not use the air cylinder as an air-hydro cylinder.**
If working fluid of the air cylinder is turbine oil, oil leakage can result.
- **Grease is applied to cylinder.**
- **The base oil of grease may seep out.**

The base oil of grease in the cylinder may seep out of the tube, cover, crimped part or rod bushing depending on the operating conditions (ambient temperature 40 °C or more, pressurized condition, low frequency operation).

2-3. Mounting and Installation

- 1) There is a tolerance location diameter at the end surface of the cover specifically for accurate alignment when mounting.
- 2) The foot mounting cylinder has a hole in the foot to drive a pin into for accurate positioning and fixing.

Caution

- **Do not apply excessive lateral load to the piston rod.**

The bold solid lines in Fig. 1 show the allowable lateral load on the cylinder for a certain stroke length.

Refer to Table 2 Maximum Allowable Kinetic Energy.(Page 10)

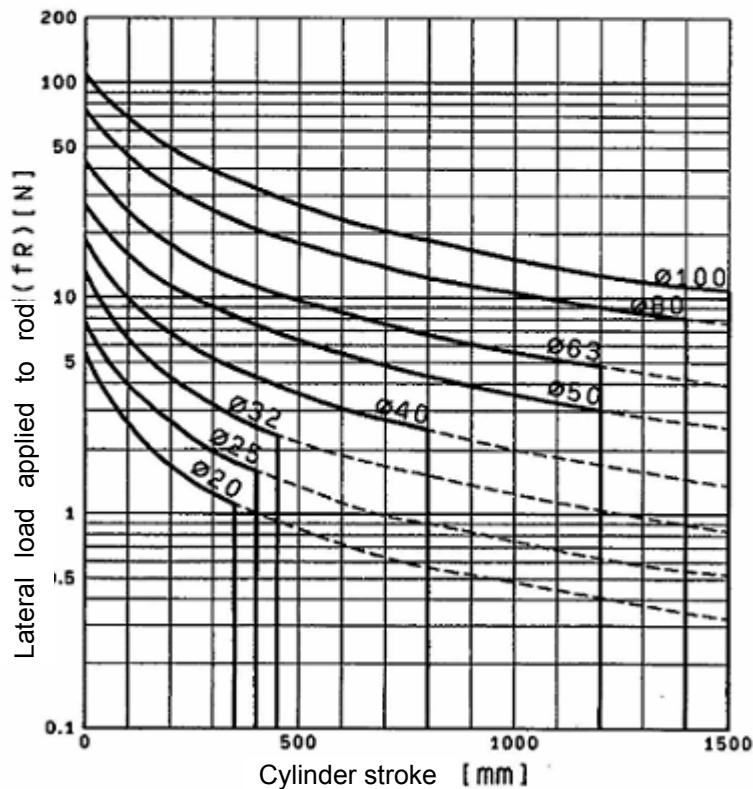
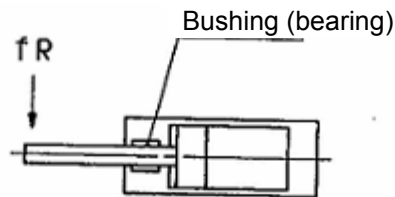

Fig. 1 Allowable lateral load applied to rod end

Calculation for excessive lateral load:

Minimum operating pressure value after the device is mounted (MPa) = Cylinder's minimum operating pressure(MPa) + {Load weight(kg)

× Guide friction coefficient / Cylinder's cross section (mm²)}

If the product is found to operate smoothly with the calculated pressure, it has been determined that the alignment of the guides have not created additional loading on the cylinder.

- 3) When female rod end is used, use a washer, etc. to prevent the contact part at the rod end from being deformed depending on the material of the work piece.
- 4) For the female rod end thread type, spanner flap (K and KA portions) will be inside of the bracket when the piston rod is retracted at the stroke end. Extend the piston rod to tighten the nut using a tool, and mount a workpiece on the rod end.
- 5) Be careful not to apply vibration or impact to the cylinder body when it is operated while fixed on one side and free on the other side (basic type, flange type). Bending moment may be applied to the cylinder by vibration generated at the stroke end, which can damage the cylinder.

In such a case, install a support bracket to suppress the vibration of the cylinder body or decrease the piston speed until the cylinder body does not vibrate at the stroke end.

Use a support bracket also when moving the cylinder body or when a cylinder is mounted horizontally and fixed at one end.

- **Be sure to connect the piston rod and the load so that their axial centers and movement directions match.**

If they do not match, stress could be applied to the rod and the cylinder tube, causing the inner surface of the cylinder tube, the bushing, the rod surface, and the seals to wear and become damaged.

- **When an external guide is used, connect the piston rod end and the load in such a way that there is no interference at any point within the stroke.**
- **Refer to the torque in Table-1 when tightening the foot, flange and clevis to the cylinder.**

Table 1 Tightening torque (Unit: Nm)

	Foot Flange Clevis	Trunnion
CG1*20	1.5	2.2
CG1*25	2.9	3.6
CG1*32	2.9	9.0
CG1*40	4.9	18.1
CG1*50	11.8	31.9
CG1*63	24.5	52.0
CG1*80	24.5	---
CG1*100	42.2	---

- **When female rod end is used, use a washer, etc. to prevent the contact part at the rod end from being deformed depending on the material of the work piece.**

- **Do not hit or grasp the sliding parts of the cylinder tube and piston rod with other objects.**

The internal diameter of the tube and the sliding part of the piston rod are manufactured to precise tolerances, so that even a slight deformation may cause faulty operation.

Also, scratches or gouges, etc., in the piston rod may lead to damaged seals and cause air leakage.

- **Prevent the stoppage of rotating parts.**

Prevent the stoppage of rotating parts (pins, etc.) by applying grease.

- **Do not use the product until you have verified that the equipment can operate properly.**

After installation or repair, apply air and power supplies to the equipment and perform appropriate functional and leakage inspections to make sure the equipment is mounted properly.

- **Do not let foreign matter such as cutting chips get into the product from the supply port.**

When the product is installed on a machine on site, the debris from drilled mounting holes can get in the supply port of the product. Take sufficient care to prevent this.

- For the female rod end thread type, spanner flap will be inside of the bracket when the piston rod is retracted at the stroke end. Extend the piston rod to tighten the nut using a tool, and mount a workpiece on the rod end.

2-4. Environment

Warning

- Do not use in environments where there is a danger of corrosion.
- Install a cover over the rod if it is used in an area that is dusty, or in an environment in which water or oil splashes on the cylinder.
Contact SMC if the operating location contains a lot of dust.
- Avoid storing the product in humid conditions.
Store the product with the piston rod retracted and avoid humidity, in order to prevent generation of rust.

Caution

- **Preparation before piping**
Before piping, perform air blow (flushing) or cleaning to remove any cutting chips, cutting oil, dust, etc. from the piping and fitting.
- **Wrapping of sealant tape**
When screwing piping or fittings into ports, ensure that chips from the pipe threads or sealing material do not enter the piping.
Also, if sealant tape is used, leave 1.5 to 2 thread ridges exposed at the end of the threads.

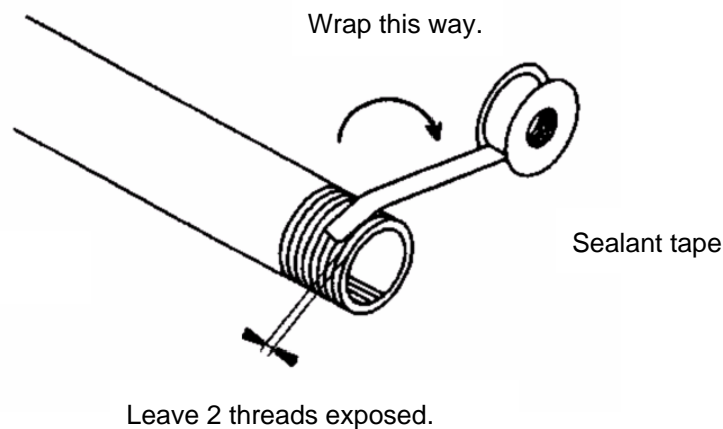

Fig. 2 Sealant tape

2-5. Speed control

When the piston speed is adjusted, install SMC AS series speed controller near the air supply port to adjust to the specified speed. There are two methods of speed adjustment, one is to restrict air supplied to the product (meter-in), and the other is to restrict air exhausted from the product (meter-out). Normally, the meter-out type should be adopted.

Caution

- Piston speed should be controlled gradually from low speed to the specified speed with a speed controller fully closed.

2-6. Allowable kinetic energy

The product has a rubber bumper at both ends of the piston or the cover, which can soften the shock at stroke end and reduce the noise created during operation and by the shock. This feature enables the use of the product at a high frequency or high speed operation.

Caution

- When the product is equipped with a rubber bumper, note that there will be a slight bounce at the stroke end.

The applied kinetic energy must be within the allowable value when an inertial load is actuated.

Please refer to "Fig.1 Allowable lateral load applied to rod end ".(Page 7)

Table 2 **Maximum Allowable Kinetic Energy**

Bore size (mm)	20	25	32	40	50	63	80	100
Male rod end	0.28	0.41	0.66	1.20	2.00	3.40	5.90	9.90
Female rod end	0.11	0.18	0.29	0.52	0.91	1.54	2.71	4.54

(J)

Kinetic energy $E (J) = \frac{(m_1 + m_2)V^2}{2}$
 m₁: Mass of cylinder movable parts kg
 m₂: Load mass kg
 V : Piston speed at the end m/s

Table 3 **Weights of Cylinder Movable Parts**

Bore size (mm)	20	25	32	40	50	63	80	100
Male rod end	40.0	68.5	96.0	209.7	379.1	409.7	827.8	1259.7
Female rod end	30.9	51.7	77.0	161.0	282.0	312.5	637.4	991.5

(g)

Table 4 **Additional Weights**

Bore size (mm)	20	25	32	40	50	63	80	100
Additional weight per 50 mm of stroke	19.6	30.6	44.1	78.4	122.5	122.5	191.4	275.7
Switch magnet	3.5	4.0	9.0	12.6	14.0	22.0	24.0	35.0

(g)

* Do not apply a lateral load over the allowable range to the rod end when it is mounted horizontally.

Standard weight of movable parts

Calculation (Example) **CDG1BN40-150Z** (Built-in magnet, Basic type, ø40, 150 stroke)

- Standard weight of movable parts: Male rod end, Bore size [40] 209.7 g
- Additional weight: Additional weight of stroke 78.4 x 150/50 = 235.2 g 235.2 g
- Switch magnet 12.6 g

Total 457.5 g

The allowable kinetic energy is different between the cylinders with male rod end and with female rod end due to the different thread sizes.

Warning

- **Use the actuator with allowable kinetic energy (Page 10, Table 2) or less.**
Operation with a kinetic energy over the allowable value can break the product and cause injury or damage to equipment. If excessive kinetic energy is expected, install an external absorber to prevent impact to the body of the product. In this case, please verify the rigidity of the equipment carefully.

2-7. Control of direction

To switch the operating direction of the cylinder, mount an applicable solenoid valve selected from SMC's range of solenoid valves.

Warning

- **Design a circuit to prevent sudden action of a driven object.**
When the product is actuated by an exhaust center type directional control valve or when one side of the piston is pressurized with air exhaust, such as when the product is started after the exhaust of the residual pressure from the circuit, driven objects may act suddenly at high speed. In such cases, injury may occur, such as hands or feet getting caught in the machinery, or damage to the machinery itself may occur. Design the machinery to avoid such dangers.

2-8. Auto switches

When an auto switch is mounted or its set position is changed, refer to Fig. 3, 4 and 5.

Caution

- Use a specific mounting bracket (Page 14, Table 5) and mount the product so that the band of the bracket will be perpendicular to the stroke of the product.
- Tighten mounting screws to the appropriate torque.
- The auto switch can only be used for cylinders with a built-in magnet for auto switch (e.g. CDG1).
- The mounting of the switch is limited depending on stroke.
(See page 16, Table 7.)

< Applicable Auto switches >

Solid state auto switch D-G59, D-G5P, D-K59, D-G5BA
D-G59W·D-G5PW·D-K59W
D-G59F·D-G5NT

Reed auto switch D-B54·D-B64·D-B59W

< Applicable Auto switches >

Solid state auto switch D-H7BAL, D-H7NF

Reed auto switch D-C73C, D-C80C

Fig. 3 Mounting and movement of the auto switch

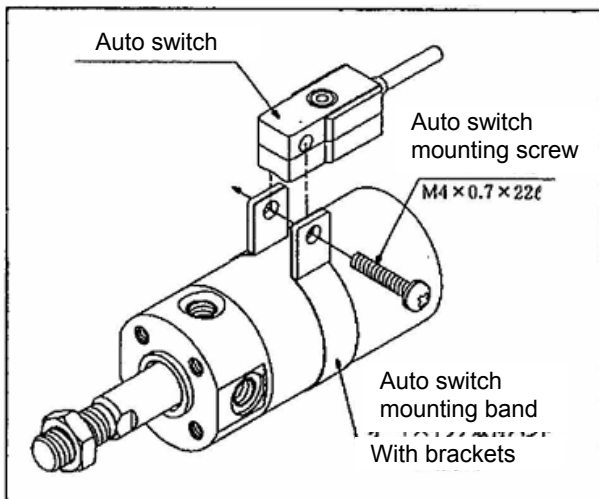

- (1) Wind a band on the cylinder tube to roughly set the auto switch mounting position.
- (2) Put the mounting part of the auto switch between the clasps of the band of the bracket, and match the mounting hole of the switch to the holes of the clasps.
- (3) Turn the mounting screw slightly into the threads of the band through the mounting hole.
- (4) Confirm where the detecting position is, and tighten the mounting screw to fix the auto switch. (The tightening torque of the M4 screw must be 1 to 1.2Nm.)
- (5) The detection position can be changed under the conditions in step 3.

Fig. 4 Mounting and movement of the auto switch

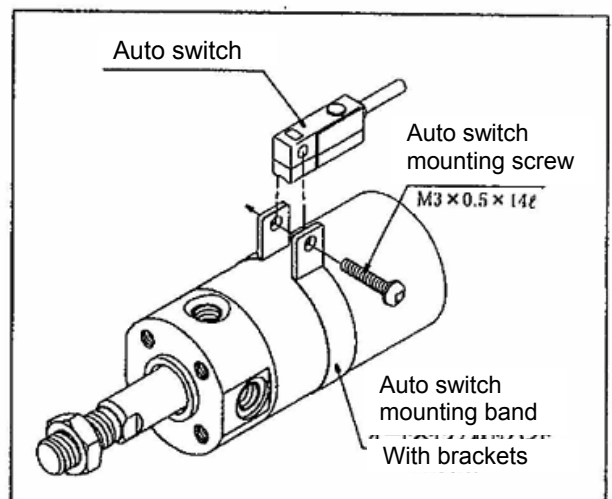

- (1) Wind a band on the cylinder tube to roughly set the auto switch mounting position.
- (2) Put the mounting part of the auto switch between the clasps of the band of the bracket, and match the mounting hole of the switch to the holes of the clasps.
- (3) Turn the mounting screw slightly into the threads of the band through the mounting hole.
- (4) Confirm where the detecting position is, and tighten the mounting screw to fix the auto switch. (The tightening torque of the M3 screw must be 0.6 to 1Nm.)
- (5) The detection position can be changed under the conditions in step 3.

< Applicable Auto switches >

Solid state auto switch D-M9N, M9P, M9B, M9N V, M9PV, M9BV
 D-M9NW·M9PW·M9BW·M9NW V·M9PWW·M9BWV
 D-M9NA·M9PA·M9BA·M9NA V·M9PAV·M9BAV
 Reed auto switch D-A90, A93, A96, A90V, A93V, A96V

⚠ Caution

- (1) Ensure that the tightening torque is within the specified range.
- (2) Make sure that auto switch mounting band is not slanted.

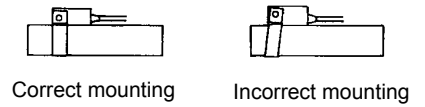
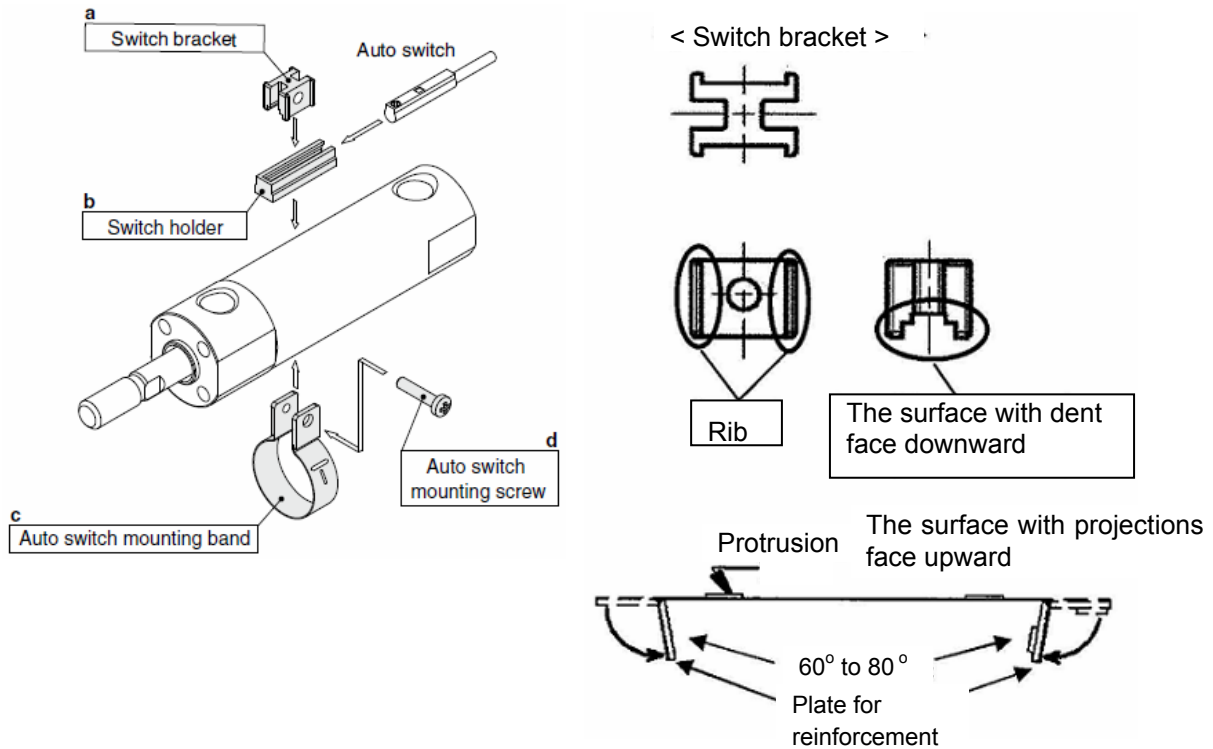

Fig. 5 Mounting and movement of the auto switch



Mounting method of auto switch

- (1) Set the mounting band for the auto switch roughly at the auto switch set position of the cylinder tube.
- (2) Place the switch holder at the opening of (1).
- (3) Face the switch bracket surface with a dent downward to place it on (2).
 Set the auto switch mounting band so that the both ends of the band are positioned between the switch bracket ribs.
 For D-M9□A(V), avoid mounting the switch bracket near the indicator LED. As the indicator LED protrudes from the switch unit, mounting the switch bracket above the LED may cause damage to it.
- (4) Insert the auto switch mounting screw (M3) included in accessories from the mounting hole of the auto switch mounting band, inserting the through hole of the switch bracket. Then, screw the mounting screw to M3 female screw of the auto switch mounting band.
- (5) Tighten the auto switch mounting screw with specified tightening torque (0.6 to 0.7 Nm).
- (6) Insert the auto switch to the auto switch mounting groove of the switch holder (2).
- (7) After checking the detecting position, tighten the mounting screw (M2.5) to fix the auto switch.
 Tightening torque is 0.05 to 0.1Nm.
 For the tightening of the mounting screws of auto switch, use a watchmaker's screwdriver with a handle diameter of about 5 to 6 mm.

Auto switch position adjusting method

- 1) For fine adjustment, loosen the mounting screw (M2.5) and slide the switch within the mounting groove of the auto switch holder.
- 2) Otherwise, loosen the mounting screw (M3) of the auto switch mounting band, and slide the switch holder on the cylinder tube.

< Cautions for BMA3 >

When the auto switch mounting screw is loosened after assembling the auto switch mounting band, the switch bracket, switch holder, auto switch mounting screw and auto switch mounting band may come off.

Table 5 Auto Switch Mounting Brackets/Part No.

Auto switch model	Bore size (mm)							
	20	25	32	40	50	63	80	100
D-M9□(V) D-M9□W(V) D-A9□(V)	Note 1) BMA3-020	Note 1) BMA3-025	Note 1) BMA3-032	Note 1) BMA3-040	Note 1) BMA3-050	Note 1) BMA3-063	—	—
D-M9□A(V)	Note 2) BMA3-020S	Note 2) BMA3-025S	Note 2) BMA3-032S	Note 2) BMA3-040S	Note 2) BMA3-050S	Note 2) BMA3-063S	—	—
D-C7□/C80 D-C73C/C80C D-H7□ D-H7□W D-H7NF D-H7BA	BMA2-020A	BMA2-025A	BMA2-032A	BMA2-040A	BMA2-050A	BMA2-063A	—	—
D-B5□/B64 D-B59W D-G5□/K59 D-G5□W/K59W D-G5BA/G59F D-G5NT D-G5NB	BA-01	BA-02	BA-32	BA-04	BA-05	BA-06	BA-08	BA-10

Note 1) Set part number which includes the auto switch mounting band (BMA2-□□□A) and the holder kit (BJ5-1/Switch bracket: Transparent).
 Since the switch bracket (made from nylon) are affected in an environment where alcohol, chloroform, methylamines, hydrochloric acid or sulfuric acid is splashed over, so it cannot be used. Please consult SMC regarding other chemicals.

Note 2) Set part number which includes the auto switch mounting band (BMA2-□□□AS/Stainless steel screw) and the holder kit (BJ4-1/Switch bracket: White).
 Avoid the indicator LED for mounting the switch bracket. As the indicator LED is projected from the switch unit, indicator LED may be damaged if the switch bracket is fixed on the indicator LED.

[Stainless Steel Mounting Screw]

The following stainless steel mounting screw kit is available. Use it in accordance with the operating environment. (Since the auto switch mounting bracket is not included, order it separately.)
 BBA3: For D-B5/B6/G5/K5 types
 BBA4: For D-C7/C8/H7 types

Note 3) Refer to page 1357 in Best Pneumatics No. 2 for details on the BBA3.
 The above stainless steel screws are used when a cylinder is shipped with the D-H7BA or G5BA auto switches.
 When only an auto switch is shipped independently, the BBA3 or BBA4 is attached.

Table 6 Operating Range

Auto switch model	Bore size (mm)							
	20	25	32	40	50	63	80	100
D-M9□(V) D-M9□W(V) D-M9□A(V)	4.5	5.0	4.5	5.5	5.0	5.5	—	—
D-A9□	7	6	8	8	8	9	—	—
D-C7/C80 D-C73C/C80C	8	10	9	10	10	11	—	—
D-B5□/B64 D-B59W	8	10	9	10	10	11	11	11
D-H7□/H7□W D-H7NF/H7BA	4	4	4.5	5	6	6.5	—	—
D-H7C	7	8.5	9	10	9.5	10.5	—	—
D-G5□/G5□W/G59F D-G5BA/K59/K59W	4	4	4.5	5	6	6.5	6.5	7
D-G5NT D-G5NB	4	4	4.5	5	6	6.5	6.5	7
	35	40	40	45	45	45	45	50

* Values which include hysteresis are for guideline purposes only, they are not a guarantee (assuming approximately ±30% dispersion) and may change substantially depending on the ambient environment.

Auto Switch Proper Mounting Position (Detection at stroke end) and Its Mounting Height

Solid state auto switch
D-M9□/M9□W, D-M9□A
 ø20 to ø63

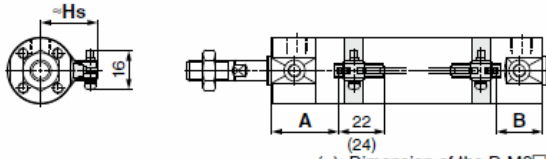

(): Dimension of the D-M9□A.
 A and B are the dimensions from the end of the head cover/rod cover to the end of the auto switch.

Reed auto switch
D-A9□
 ø20 to ø63

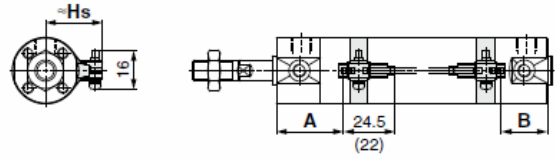

(): Dimension of the D-A96.
 A and B are the dimensions from the end of the head cover/rod cover to the end of the auto switch.

D-M9□V/M9□WV, D-M9□AV
 ø20 to ø63

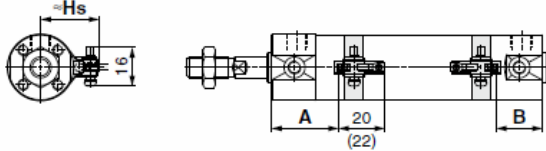

(): Dimension of the D-M9□AV.
 A and B are the dimensions from the end of the head cover/rod cover to the end of the auto switch.

D-A9□V
 ø20 to ø63

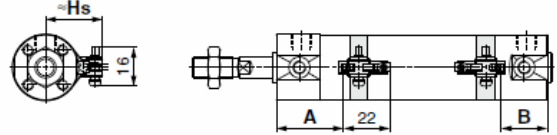

A and B are the dimensions from the end of the head cover/rod cover to the end of the auto switch.

D-G5/K5/G5□W/G5BA
D-K59W, D-G59F, D-G5NT
 ø20 to ø100

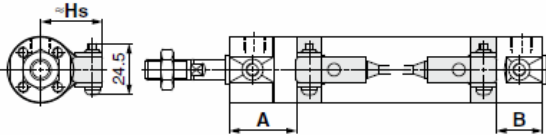

D-C7/C8, D-C73C/C80C
 ø20 to ø63

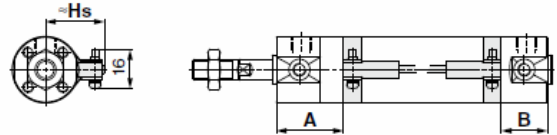

D-H7□/H7□W
D-H7NF/H7BA/D-H7C
 ø20 to ø63

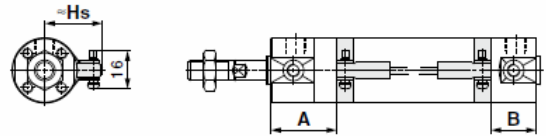

D-B5/B6/B59W
 ø20 to ø100

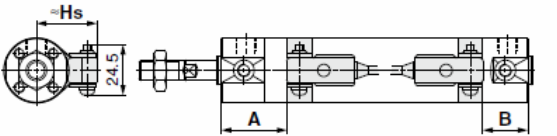

Auto Switch Proper Mounting Position

(mm)

Auto Switch Mounting Height

(mm)

Auto switch model	Auto Switch Proper Mounting Position												Auto Switch Mounting Height							
	D-M9□(V) D-M9□W(V) D-M9□A(V)		D-A9□(V)		D-C7/C8 D-C73C D-C80C		D-B5 D-B6		D-B59W		D-H7□ D-H7C D-H7□W D-H7BA D-H7NF		D-G5□W D-K59W D-G59F D-G5 D-K5 D-G5NT D-G5BA		Auto switch model	D-M9□V D-M9□WV D-M9□AV D-A9□V	D-M9□ D-M9□W D-M9□A D-A9□	D-H7□ D-H7□W D-H7NF D-H7BA D-C7/C8	D-C73C D-C80C	D-G5/K5 D-G5W D-K59W D-H7C D-B5/B6 D-G5BA D-B59W
Bore size	A	B	A	B	A	B	A	B	A	B	A	B	A	B						
20	33	24	29	20	29.5	20.5	23.5	14.5	26.5	17.5	28.5	19.5	25	16	20	25.5	24.5	27	27.5	
25	32.5	24.5	28.5	20.5	29	21	23	15	26	18	28	20	24.5	16.5	25	28	27	29.5	30	
32	34	25	30	21	30.5	21.5	25	15.5	27.5	18.5	29.5	20.5	26	17	32	31.5	30.5	33	33.5	
40	39	27	35	23	35.5	23.5	29.5	17.5	32.5	20.5	34.5	22.5	31	19	40	36	35	37.5	38	
50	46	32	42	28	42.5	28.5	36.5	22.5	39.5	26	41.5	27.5	38	24	50	41.5	40.5	43	43.5	
63	44.5	33.5	40.5	29.5	41	30	35	24	38	27	40	29	36.5	25.5	63	48.5	47.5	50	50.5	
80	—	—	—	—	—	—	—	48	29	51	32	53	34	50	80	—	—	—	59	
100	—	—	—	—	—	—	—	47	30	50	32.5	52	35	48.5	100	—	—	—	69.5	

Note) Adjust the auto switch after confirming the operating condition in the actual setting.

Table 7 Minimum Stroke for Auto Switch Mounting

n: Number of auto switches (mm)

Auto switch model	Number of auto switches				
	With 1 pc.	With 2 pcs.		With n pcs.	
		Different surfaces	Same surface	Different surfaces	Same surface
D-M9□	5	15 <i>Note 1)</i>	40 <i>Note 1)</i>	$20 + 35 \frac{(n-2)}{2}$ (n=2, 4, 6...)	$55 + 35(n-2)$ (n=2, 3, 4, 5...)
D-M9□W	10	15 <i>Note 1)</i>	40 <i>Note 1)</i>	$20 + 35 \frac{(n-2)}{2}$ (n=2, 4, 6...)	$55 + 35(n-2)$ (n=2, 3, 4, 5...)
D-M9□A	10	25	40 <i>Note 1)</i>	$25 + 35 \frac{(n-2)}{2}$ (n=2, 4, 6...)	$60 + 35(n-2)$ (n=2, 3, 4, 5...)
D-A9□	5	15	30 <i>Note 1)</i>	$15 + 35 \frac{(n-2)}{2}$ (n=2, 4, 6...)	$50 + 35(n-2)$ (n=2, 3, 4, 5...)
D-M9□V	5	20	35	$20 + 35 \frac{(n-2)}{2}$ (n=2, 4, 6...)	$35 + 35(n-2)$ (n=2, 3, 4, 5...)
D-A9□V	5	15	25	$15 + 35 \frac{(n-2)}{2}$ (n=2, 4, 6...)	$25 + 35(n-2)$ (n=2, 3, 4, 5...)
D-M9□WV D-M9□AV	10	20	35	$20 + 35 \frac{(n-2)}{2}$ (n=2, 4, 6...)	$35 + 35(n-2)$ (n=2, 3, 4, 5...)
D-C7□ D-C80	5	20	60	$20 + 45 \frac{(n-2)}{2}$ (n=2, 4, 6...)	$60 + 45(n-2)$ (n=2, 3, 4, 5...)
D-H7□ D-H7□W D-H7BA D-H7NF	10	25	70	$25 + 45 \frac{(n-2)}{2}$ (n=2, 4, 6...)	$70 + 45(n-2)$ (n=2, 3, 4, 5...)
D-C73C D-C80C D-H7C	5	30	80	$30 + 50 \frac{(n-2)}{2}$ (n=2, 4, 6...)	$80 + 50(n-2)$ (n=2, 3, 4, 5...)
D-B5□ D-B64 D-G5□ D-K59□	5	25	70	$25 + 50 \frac{(n-2)}{2}$ (n=2, 4, 6...)	$70 + 50(n-2)$ (n=2, 3, 4, 5...)
D-B59W	10	30	75	$30 + 50 \frac{(n-2)}{2}$ (n=2, 4, 6...)	$75 + 50(n-2)$ (n=2, 3, 4, 5...)



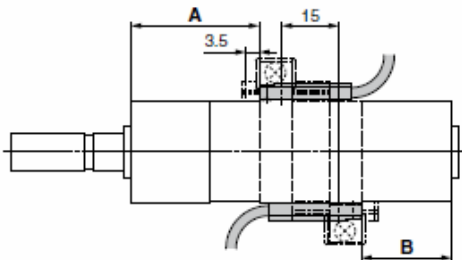
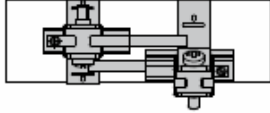



Note 1) Auto switch mounting

Auto switch model	With 2 auto switches	
	Different surfaces	Same surface
	 <p>Correct auto switch mounting position is 3.5 mm from the back face of the switch holder.</p>	 <p>The auto switch is mounted by slightly displacing it in a direction (cylinder tube circumferential exterior) so that the auto switch and lead wire do not interfere with each other.</p>
D-M9□ D-M9□W	Less than 20 stroke <i>Note 2)</i>	Less than 55 stroke <i>Note 2)</i>
D-M9□A	Less than 20 stroke <i>Note 2)</i>	Less than 60 stroke <i>Note 2)</i>
D-A9□	—	Less than 50 stroke <i>Note 2)</i>

Note 2) Minimum stroke for auto switch mounting in styles other than those mentioned in Note 1.

Table 8 **Cylinder Mounting Bracket, by Stroke/Auto Switch Mounting Surfaces**

st: Stroke (mm)

Auto switch model	Basic, Foot, Flange, Clevis			Trunnion		
	With 1 pc. (Rod cover side)	With 2 pcs. (Different surfaces)	With 2 pcs. (Same surface)	With 1 pc. (Rod cover side)	With 2 pcs. (Different surfaces)	With 2 pcs. (Same surface)
Switch mounting surface	Port surface 	Port surface 	Port surface 			
Switch type						
D-M9□(V) D-M9□W(V) D-M9□A(V) D-A9□	10 st or more	15 to 44 st	45 st or more	10 st or more	15 to 44 st	45 st or more
D-C7/C8	10 st or more	15 to 49 st	50 st or more	10 st or more	15 to 49 st	50 st or more
D-H7□/H7□W D-H7BA/H7NF	10 st or more	15 to 59 st	60 st or more	10 st or more	15 to 59 st	60 st or more
D-C73C/C80C/H7C	10 st or more	15 to 64 st	65 st or more	10 st or more	15 to 64 st	65 st or more
D-B5/B6/G5/K5 D-G5□W/K59W/G5BA D-G59F/G5NT	10 st or more	15 to 74 st	75 st or more	10 st or more	15 to 74 st	75 st or more
D-B59W	15 st or more	20 to 74 st	75 st or more	15 st or more	20 to 74 st	75 st or more

* Trunnion type is not available for ø80 and ø100.

Other than the applicable auto switches listed in “How to Order”, the following auto switches are mountable.

Refer to pages 1263 to 1371 in Best Pneumatics No. 2 for detailed specifications.

Type	Model	Electrical entry	Features	Applicable bore size (mm)
Solid state	D-H7A1/H7A2/H7B	Grommet (In-line)	—	ø20 to ø63
	D-H7NW/H7PW/H7BW		Diagnostic indication (2-color indication)	
	D-H7BA		Water resistant (2-color indication)	
	D-G5NT		With timer	ø20 to ø100
Reed	D-C73/C76		—	ø20 to ø63
	D-C80		Without indicator light	
	D-B53		—	ø20 to ø100

* With pre-wired connector is also available for solid state auto switches. For details, refer to pages 1328 and 1329 in Best Pneumatics No. 2.

* Normally closed (NC = b contact) solid state auto switches (D-F9G/F9H) are also available. For details, refer to page 1290 in Best Pneumatics No. 2.

* Wide range detection type, solid state auto switch (D-G5NBL) is also available. For details, refer to page 1320 in Best Pneumatics No. 2.

Auto Switch Connection and Example

Sink Input Specifications

3-wire, NPN

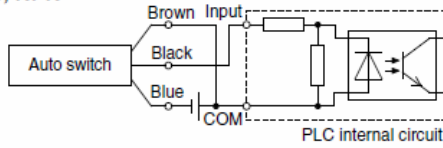

2-wire

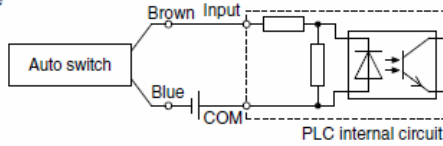

Source Input Specifications

3-wire, PNP

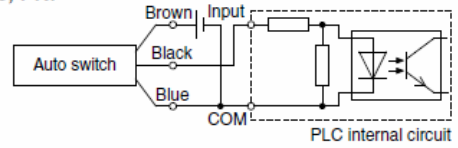

2-wire

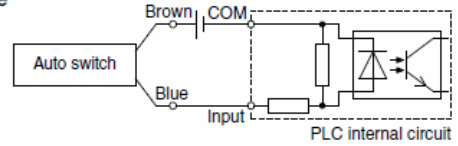

Connect according to the applicable PLC input specifications, as the connection method will vary depending on the PLC input specifications.

Example of AND (Series) and OR (Parallel) Connection

3-wire, AND connection for NPN output (Using relays)

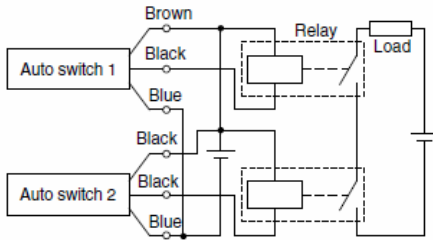

(Performed with auto switches only)

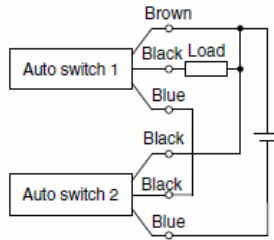

3-wire, OR connection for NPN output

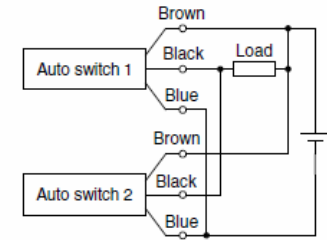

3-wire, AND connection for PNP output (Using relays)

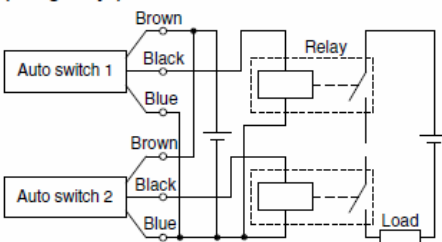

(Performed with auto switches only)

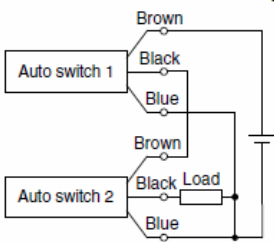

3-wire, OR connection for PNP output

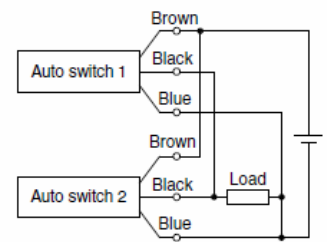

2-wire, AND connection

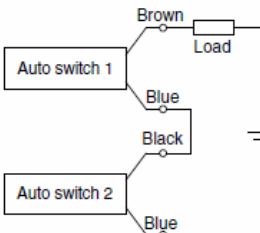

When two auto switches are connected in series, malfunction may occur because the load voltage will decrease in the ON state. The indicator lights will light up when both of the auto switches are in the ON state.

$$\begin{aligned} \text{Load voltage at ON} &= \text{Power supply voltage} - \text{Residual voltage} \times 2 \text{ pcs.} \\ &= 24 \text{ V} - 4 \text{ V} \times 2 \text{ pcs.} \\ &= 16 \text{ V} \end{aligned}$$

Example: Power supply voltage 24 VDC
Auto switch internal voltage drop 4 V

2-wire, OR connection

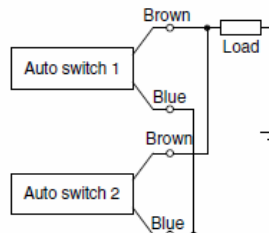

(Solid state)
When two auto switches are connected in parallel, malfunction may occur because the load voltage will increase in the OFF state.

(Reed)
Because there is no leakage current, the load voltage will not increase in the OFF state. However, depending on the number of auto switches in the ON state, the indicator lights may sometimes grow dim or not light up, due to the dispersion and reduction of the current flowing to the auto switches.

$$\begin{aligned} \text{Load voltage at OFF} &= \text{Leakage current} \times 2 \text{ pcs.} \times \text{Load impedance} \\ &= 1 \text{ mA} \times 2 \text{ pcs.} \times 3 \text{ k}\Omega \\ &= 6 \text{ V} \end{aligned}$$

Example: Load impedance 3 kΩ
Auto switch leakage current 1 mA

3. Maintenance

3-1. Checks

The following checks are required for proper cylinder operation.

- 1) Smooth operation
- 2) Changes in piston speed and cycle time
- 3) Abnormal stroke
- 4) Looseness of mounting bolt and rod end nuts
- 5) Looseness of mounting frame and excessive deflection
- 6) Internal and external leakage (Change in output)
- 7) Damage to the piston rod sliding surface
- 8) Clogging and discharge drainage of the air filter
- 9) Lubrication of rotating parts (double knuckle joint, clevis pin, etc.)
- 10) Position of auto switches

When any abnormality is found as a result of checking the points above, eliminate causes and take necessary measures such as retightening screws and the application of grease. Contact SMC sales if it is necessary to repair the cylinder.

Warning

- **As a minimum, maintenance should be performed according to the above items. Perform additional maintenance as necessary.**
Improper handling can cause damage and malfunction of equipment and machinery.
- **Removal of equipment, and supply/exhaust of compressed air.**
Ensure that drop prevention measures and safe lock out of the moving parts are taken, the power of the facility and supply air is shut off and the compressed air in the system is exhausted before removing the equipment.
Before restarting the equipment, confirm that measures are taken to prevent sudden action.

3-2. Replacement of seals

It is possible to replace the rod seal, piston seal, cylinder tube gasket and wear ring for $\phi 20$ to $\phi 40$.

Contact SMC sales if it is necessary to replace seal for $\phi 50$ to $\phi 100$.

Contact SMC sales if it is necessary to replace parts other than those mentioned above.

Warning

- **Only people who have sufficient knowledge and experience are allowed to replace seals.**
The person who disassembles and reassembles the cylinder is responsible for the safety of the product.

Caution

- **When replacing seals, carefully handle parts to prevent injury to your hands or fingers on the corners of parts.**

3-2-1. Disassembly / Reassembly

Caution

- **Disassemble and assemble the cylinder on a clean cloth in a clean location. Perform on a clean cloth.**

For disassembling, hold the flats of the tube cover gently in a vice and hold the flats of the rod cover with a spanner or adjustable wrench to loosen and remove the rod cover. When reassembling, tighten 0 to 2 degrees more than the original position before disassembling.

Bore size of $\phi 50$ or more cannot be disassembled because they are tightened to a high torque. Contact your SMC Sales representative if you need to disassemble these products.

3-2-2. Removal of seals

1) Rod seal

Insert a precision screwdriver from the front of the cover to pull out the seal as shown in Fig. 6.

Caution

- **Take care not to damage the seal groove of the cover at this time.**

2) Piston seal

Wipe off grease around piston seal first to make seal removal easier.

As shown in Fig. 7, hold the piston seal with one hand and push it into the groove so that the piston seal can be lifted off and pulled out without using a precision screwdriver.

The groove of the rod cover is deep, so if the rod seal is removed with a precision screwdriver, it might be damaged.

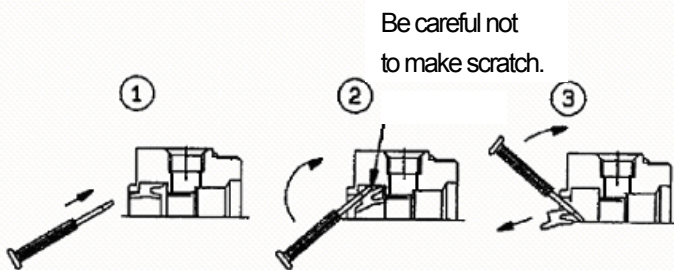

Fig. 6 How to remove rod seal

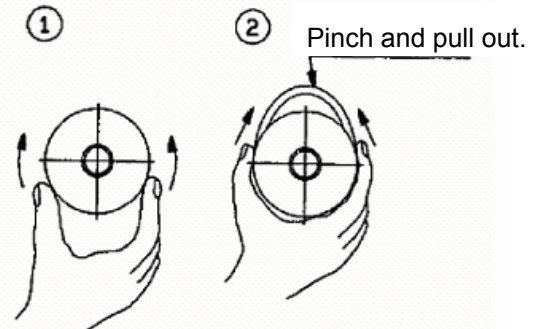

Fig. 7 How to remove piston seal

3) Tube gasket

Pull out with the precision screwdriver.

3-2-3. Grease

Caution

- Use SMC's recommended grease.

Grease pack part number: GR-S-010 (10g), GR-S-020 (20g)

Refer to Page 27 for made to order product (XC85, X446).

1) ① Rod seal

Apply a thin layer of grease to all surfaces of the new seal to make it easy to mount the rod seal and improve sealing.

Fill the groove of the seal with grease, which is necessary for operation.

2) ② Piston seal

Apply a thin layer of grease to the all surfaces of the piston seal to make it easy to mount the seal.

3) ④ Tube gasket

Apply a thin layer of grease to all surfaces of the tube gasket to make it easy to mount the gasket.

4) Parts of cylinder

Grease is applied to the locations shown in Fig. 8. The amount of grease per cylinder of 100 stroke is shown in attached table 9. Roughly, one scoop with a forefinger is approximately 3g.

$$L \doteq 100\text{mm, or stroke} \times \frac{1}{2}$$

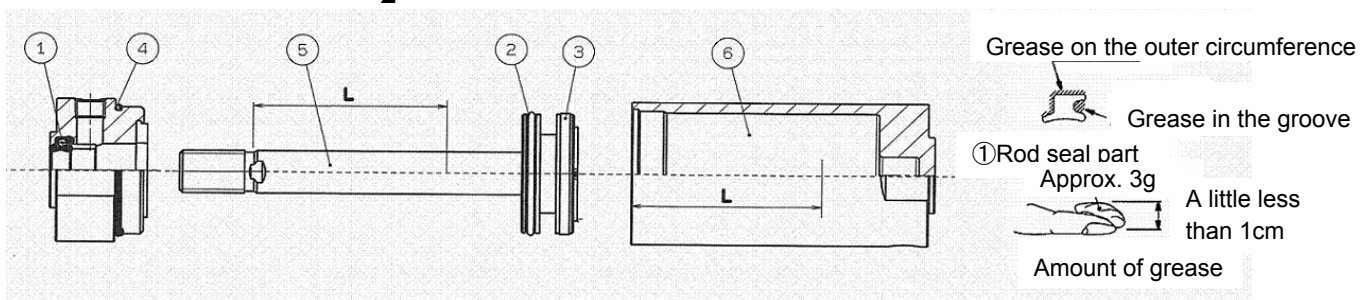

Fig. 8 Position for application of grease

Table 9 Amount of grease

units: g

Stroke \ Bore	φ20	φ25	φ32	φ40	Position for grease
At 100st	2	3	3	3 to 4	①②③④⑤⑥
50st added	0.5	0.5	0.5	1	⑤⑥

3-2-4. Mounting of seals

1) Rod seal (Fig.8, ①)

Pay attention to the mounting direction of the seal.

Apply grease all over the seal and inner surface of the bushing as shown in Fig. 9. If it is difficult to apply grease, for example to a small bore diameter, use a precision screwdriver. Do not scratch any surface with the screwdriver.

2) Piston seal (Fig. 8, ②)

Mount with care not to twist the piston seal. Apply grease to the seal groove and outer circumference by rubbing grease into them as shown in Fig. 10.

3) Tube gasket (Fig. 8, ④)

Mount with care not to twist the tube gasket.

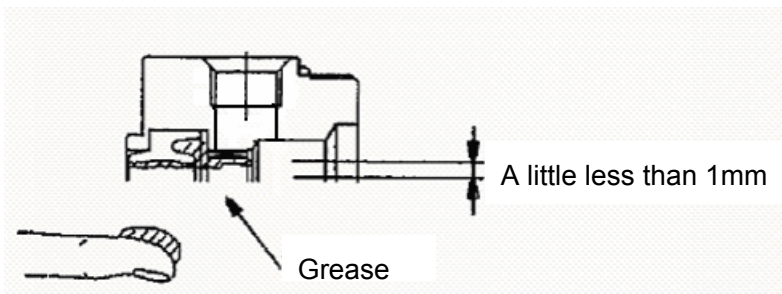

Fig. 9 Rod seal

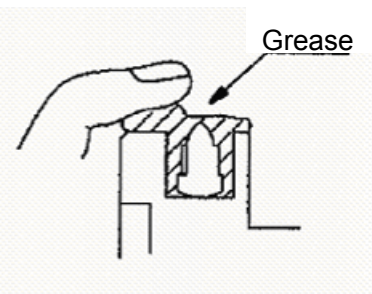

Fig. 10 Piston seal

⚠ Caution

- Confirm that there is no problem with operation and air tightness after assembly.

3-3. Consumable parts

3-3-1 Replacement parts

	φ20	φ25	φ32	φ40
Seal kit number	CG1N20Z-PS	CG1N25Z-PS	CG1N32Z-PS	CG1N40Z-PS
Grease pack (Accessory)	GR-S-010(10g)			
Contents of the seal kit	Rod seal Piston seal Tube gasket Grease pack (10g) 1pc. of each			

	φ20	φ25	φ32	φ40
Wear ring	CM-020-07-301B	CM-025-07-302B	CM-032-07-304B	C1A040-07-305B

Grease pack part number: GR-S-010(10g)
GR-S-020 (20g)

⚠ Caution

- The seal is not delivered in sealed packaging for storage independently, so it must be used within 1 year.

3-3-2. Storage of seals

Caution

- Store seals in sealed packaging such as polyethylene bag and place it in a box.
- Avoid locations exposed to direct sunlight and high temperature and humidity. In particular, isolate from equipment that can generate heat, radiation and ozone.
- Do not stack a lot of seals, or deform or damage seals by putting a heavy object on top of them.
- White particles can emerge from the surface of the seal during storage, but they do not affect its performance.

3-4. Troubleshooting

Trouble	Major causes	Countermeasures
Operation has lost smoothness.	1. Lubrication failure	- Apply the specified grease after cleaning of parts (Grease pack: GR-S-010(10g) GR-S-020(20g))
	2. Deformation of piston rod	- Replace the cylinder with a new one. When reinstalling the product, adjust the load and mounting position.
	3. Insufficient pressure	- Supply appropriate pressure.
	4. Operation at a low speed outside of the limit.	- Use a low speed cylinder.
Output force has decreased.	1. Air leakage from piston seal	- Replace the piston seal with a new one. See 3-2. Replacement of seals. (Page 19)
	2. Air leakage from rod seal	- Replace the rod seal with a new one. See 3-2. Replacement of seals. (Page 19)
	3. Insufficient air pressure	- Supply appropriate pressure.
	4. Insufficient flow rate	- The resistance in the fluid path may have increased due to deformation or foreign matter entering the product. Perform repair or cleaning.
	5. Incorrect mounting position of the product	- Mount in a proper position without any force applied to the product.
	6. Deformation of piston rod	- Replace the cylinder with a new one. When reinstalling the product, adjust the load and mounting position.
	7. Lubrication failure	- Refer to the countermeasure for the trouble "Operation has lost smoothness/ lubrication failure."
Piston speed is too fast.	1. Speed controller is not used.	- Use a speed controller suitable for the size of the product. Refer to the catalog and operation manual of the speed controller for details.
	2. Insufficient fine adjustment of speed controller	- Select a speed controller, which can be adjusted to the required speed. Refer to the catalog and operation manual of the speed controller for details.
Piston speed is too slow.	1. Directional control valve is too small.	- Select directional control valves with suitable size. Refer to the catalog and operation manual of the directional control valve for details.
	2. Resistance of equipment in the piping route is too large	- Use components and equipment of an appropriate size. It affects the piping diameter and length. Equipment at the exhaust side should also be of an appropriate size. Refer to the catalog and operation manual of the components and equipment for details.
The product sometimes does not operate.	1. Operation at a very low speed	- Operation at a very low speed can create a condition with almost no pressure difference between the supply side and exhaust side and lower sealing effect, which can cause operation failure. Keep the specified piston speed.
	2. Problem of equipment other than this product	- Check all items in the system one by one to find the cause. Refer to the catalog and operation manual of the components and equipment for details.

Trouble	Major causes	Countermeasures
The product has become unable to operate.	1. Damage of piston seal	- If there is leakage from the piston seal, it will be exhausted from the exhaust port of the directional control valve all the time. Replace the piston seal. See 3-2. Replacement of seals. (Page 19)
	2. Problem of equipment other than this product	- Check all items in the system one by one to find the cause. Refer to the catalog and operation manual of the components and equipment for details.
	3. Insufficient pressure	- Supply appropriate pressure.
The piston rod has been deformed and broken.	1. Operation at high speed	- Replace the cylinder with a new one. Operation at a high speed can cause impact from the load, and deform and damage the product. Keep within the specified piston speed and allowable kinetic energy.
	2. Excessive external force	- Structural interference, eccentric load or over-load may cause damage and deformation of the cylinder. Eliminate the cause and replace the product with a new one.
Piston speed cannot be adjusted with the speed controller.	1. Incorrect speed controller selection	- Use a speed controller suitable for the size of the product. Refer to the catalog and operation manual of the speed controller for details.
	2. Problem of the speed controller	- Replace the speed controller with a new one. Refer to the catalog and operation manual of the speed controller for details.
The product has stick and slip movement.	1. Speed too slow	- Use a low speed cylinder.
	2. Insufficient margin of output	- Supply appropriate pressure. - Replace with a product of a larger bore size.
	3. Use of a meter-in circuit	- In case of the operation with low pressure or low speed, the operation may become stable if the product is used with meter-in. Use of a meter-out circuit.
The product shows sudden and fast movement after being stopped for extended periods of time.	1. Fluctuation of residual pressure in the product between continuous operation and operation after stoppage for extended periods of time	- Consider the use of a suitable pneumatic circuit to prevent sudden action of the product.
Switch does not turn on (Switch sometimes does not turn on)	1. Power supply failure or connection failure	- Check the power supply. - Connect the product properly.
	2. Displacement of auto switch position	- Try to slide the auto switch over the product to check its ON position, and move it to a correct position.
	3. Reduction of magnetic force	- If there is a magnetic source near the product, move it away or install a shield plate to reduce the effect from the magnet. - When the product gets hot, adjust operating frequency to lower it to 60°C. - If the above measures do not resolve the problem, replace the product with a new one.

Trouble	Major causes	Countermeasures
Switch does not turn on (Switch sometimes does not turn on)	4. Lowered sensitivity of auto switch	- Eliminate the problem of ambient temperature, vibration, or impact. Replace the switch with a new one if the problem is not solved.
Switch does not turn off (Switch sometimes does not turn off)	1. Fused contact of auto switch (reed type)	- Check the voltage and load are within the specified rated values, and replace the auto switch with a new one.
	2. External magnetic field keeping auto switch on.	- If there is a magnetic source near the product, move it away or install a shield plate to reduce the effect from the magnet.

4. Made to order product (XC85, X446).

Made to order product below uses special grease.

(If mixed with other grease, optimum performance cannot be achieved.)

4-1. Food Machinery Grease Specification

Standard models -XC85

Grease pack part number: GR-H-010(10g)

Nonfood compound incidental contact.

Operating Environment



Caution

Environment for installing cylinder

Do not use in food zone.

<Not installable>

Food zone.....An environment where food which will be sold as merchandize, directly touches the cylinder's components.

Splash zone.....An environment where food which will not be sold as merchandize, directly touches the cylinder's components.

<Installable>

Non-food zone.....An environment where there is no contact with food.

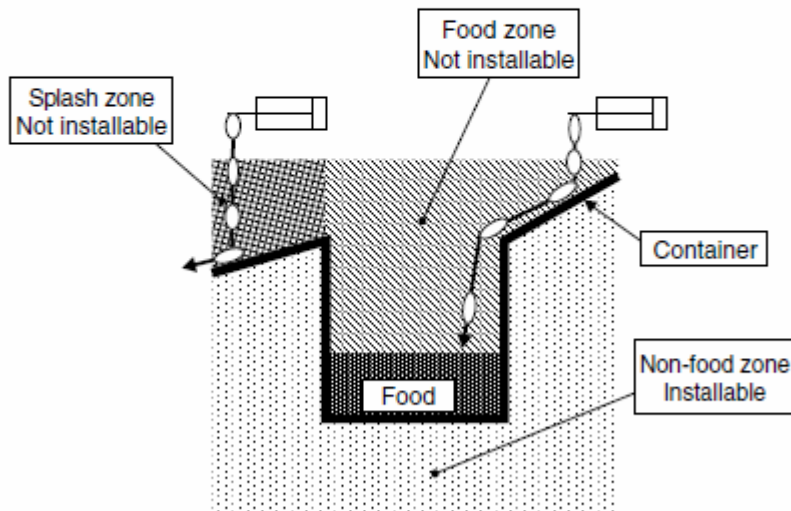

* When the product is used in an area of liquid splash, or a water resistant function is required for the product, please consult SMC.

4-2. PTFE Grease Specification

Standard models -X446

Grease pack part number: GR-F-005(5g)

Lubrication



Caution

1) Lubrication for products using special grease

Lubrication to this cylinder leads to operation failure.

If grease other than those specified is used, it may cause the operating failure.

2) Do not wipe off the grease on the sliding surface of the air cylinder.

If grease applied to the sliding surface is forcibly removed, operation failure can result.

The color of the sliding surface of the cylinder may become black if cylinder travels for long distance. In this case, the life can be lengthened by wiping off the grease and apply new grease.

(Use water to wipe off the grease. Alcohol or special solvent may damage the seal.)

5. Basic Circuit for Cylinder Operation

The basic circuit for operating the product with air filter, regulator, solenoid valve and speed controller (meter-out) is shown in the following figure.

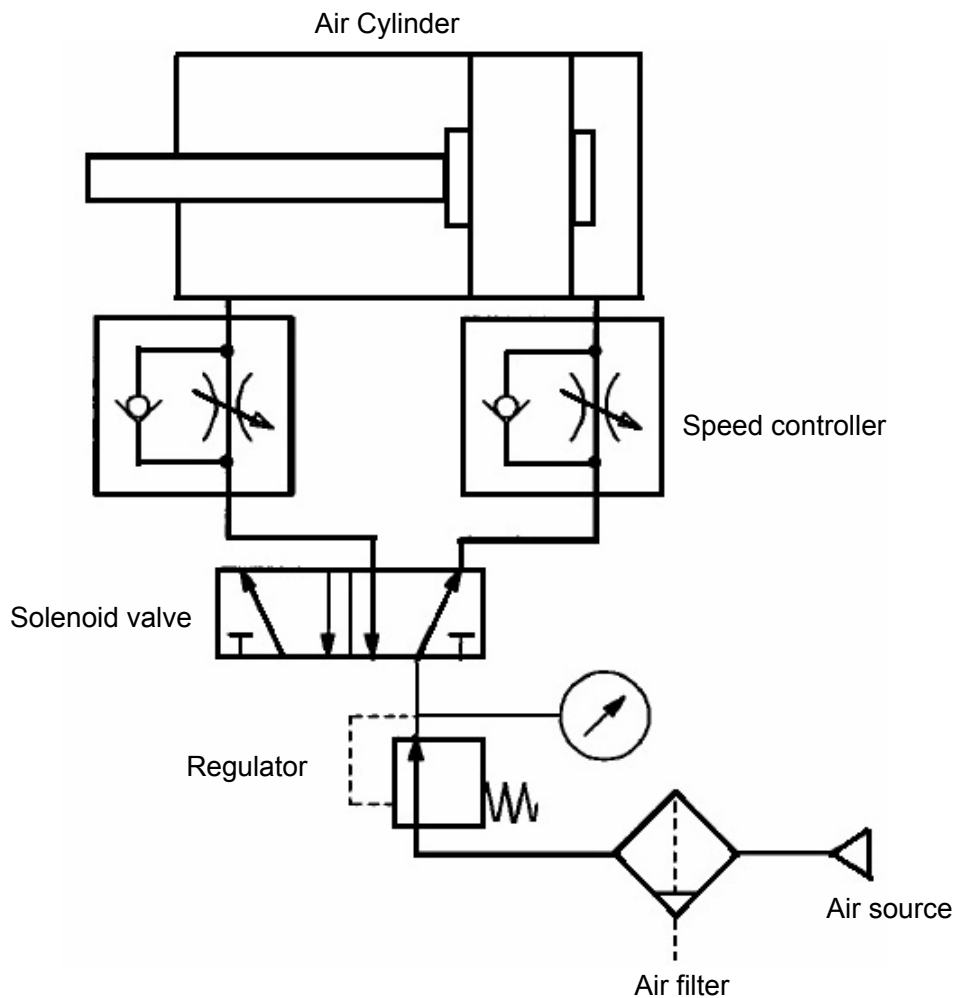

Fig. 11 Basic Circuit

6. Construction

The product with auto switch (CDG1) is equipped with a plastic magnet at the piston.

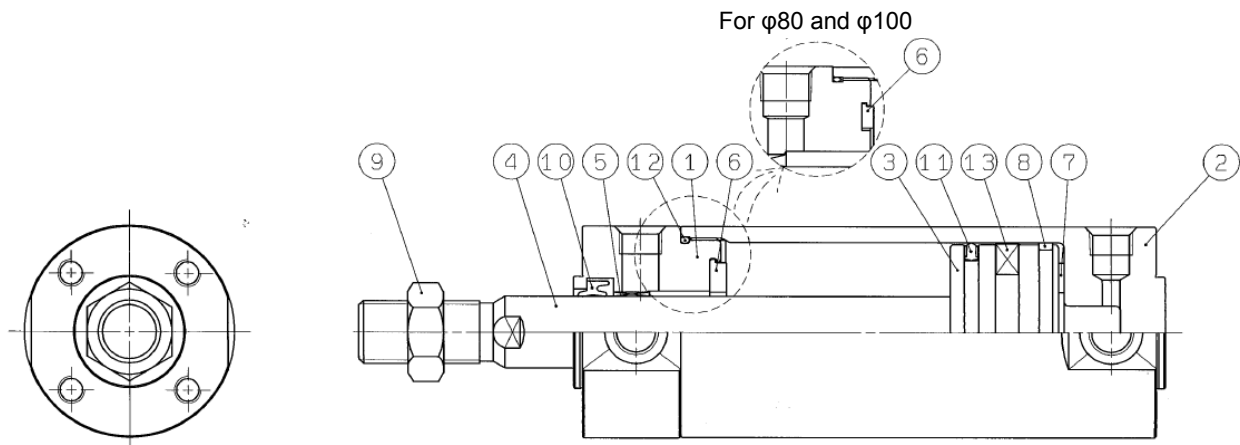

Fig. 12 Standard product: Double acting/single rod

No.	Description	Note
1	Rod cover	
2	Tube cover	
3	Piston	
4	Piston rod	
5	Bushing	
6	Bumper A	
7	Bumper B	φ32 or larger: The same as bumper A
8	Wear ring	
9	Rod end nut	
10	Rod seal	
11	Piston seal	
12	Tube gasket	
13	Plastic magnet	CDG1 (With switch)

Revision history

SMC Corporation

4-14-1, Sotokanda, Chiyoda-ku, Tokyo 101-0021 JAPAN

Tel: + 81 3 5207 8249 Fax: +81 3 5298 5362

URL <http://www.smcworld.com>

Note: Specifications are subject to change without prior notice and any obligation on the part of the manufacturer.

© 2012 SMC Corporation All Rights Reserved