



Operation Manual

PRODUCT NAME

Main Line Filter

MODEL / Series / Product Number

A F F 7 5 A - 2 0 / A F F 7 5 A - 2 0 X 1 3
A F F 1 2 5 A - 3 0 / A F F 1 2 5 A - 3 0 X 1 3
A F F 1 5 0 A - 4 0 / A F F 1 5 0 A - 4 0 X 1 3
A F F 2 2 0 A - 4 0 / A F F 2 2 0 A - 4 0 X 1 3

- This operation manual is for model number specified above.
Please confirm the consistency of the operation manual and the model number of the product to be used.
- Read this operation manual carefully and understand its content before using the product.
- Give special attention to safety instructions.
Keep this operation manual available whenever necessary.
- This operation manual may be revised without any notice.

SMC Corporation

Contents

Safety Instructions	P 2
1 . Operating Precaution	P 4
2 . Construction	P 6
3 . Specifications	P 7
1) How to Order	
2) Specifications	
4 . Installation / Piping	P 8
1) Installation	
2) Piping	
5 . Maintenance	P 9
1) Daily maintenance	
2) Element or Gasket replacement	
2 – 1 . The replacement interval for the Element or the Gasket	
2 – 2 . Element or Gasket replacement procedure	



Safety Instructions

These safety instructions are intended to prevent hazardous situations and/or equipment damage. These instructions indicate the level of potential hazard with the labels of “Caution,” “Warning” or “Danger.”

They are all important notes for safety and must be followed in addition to International Standards (ISO/IEC)*1), and other safety regulations.

*1) ISO 4414: Pneumatic fluid power -- General rules relating to systems

ISO 4413: Hydraulic fluid power -- General rules relating to systems

IEC 60204-1: Safety of machinery -- Electrical equipment of machines (Part 1: General requirements)

ISO 10218-1: Manipulating industrial robots -Safety.

etc.



Caution

Caution indicates a hazard with a low level of risk which, if not avoided, could result in minor or moderate injury.



Warning

Warning indicates a hazard with a medium level of risk which, if not avoided, could result in death or serious injury.



Danger

Danger indicates a hazard with a high level of risk which, if not avoided, will result in death or serious injury.

Warning

1. The compatibility of the product is the responsibility of the person who designs the equipment or decides its specifications.

Since the product specified here is used under various operating conditions, its compatibility with specific equipment must be decided by the person who designs the equipment or decides its specifications based on necessary analysis and test results.

The expected performance and safety assurance of the equipment will be the responsibility of the person who has determined its compatibility with the product.

This person should also continuously review all specifications of the product referring to its latest catalog information, with a view to giving due consideration to any possibility of equipment failure when configuring the equipment.

2. Only personnel with appropriate training should operate machinery and equipment.

The product specified here may become unsafe if handled incorrectly.

The assembly, operation and maintenance of machines or equipment including our products must be performed by an operator who is appropriately trained and experienced.

3. Do not service or attempt to remove product and machinery/equipment until safety is confirmed.

1. The inspection and maintenance of machinery/equipment should only be performed after measures to prevent falling or runaway of the driven objects have been confirmed.

2. When the product is to be removed, confirm that the safety measures as mentioned above are implemented and the power from any appropriate source is cut, and read and understand the specific product precautions of all relevant products carefully.

3. Before machinery/equipment is restarted, take measures to prevent unexpected operation and malfunction.

4. Contact SMC beforehand and take special consideration of safety measures if the product is to be used in any of the following conditions.

1. Conditions and environments outside of the given specifications, or use outdoors or in a place exposed to direct sunlight.

2. Installation on equipment in conjunction with atomic energy, railways, air navigation, space, shipping, vehicles, military, medical treatment, combustion and recreation, or equipment in contact with food and beverages, emergency stop circuits, clutch and brake circuits in press applications, safety equipment or other applications unsuitable for the standard specifications described in the product catalog.

3. An application which could have negative effects on people, property, or animals requiring special safety analysis.

4. Use in an interlock circuit, which requires the provision of double interlock for possible failure by using a mechanical protective function, and periodical checks to confirm proper operation.



Safety Instructions

Caution

1. The product is provided for use in manufacturing industries.

The product herein described is basically provided for peaceful use in manufacturing industries.

If considering using the product in other industries, consult SMC beforehand and exchange specifications or a contract if necessary.

If anything is unclear, contact your nearest sales branch.

Limited warranty and Disclaimer/Compliance Requirements

The product used is subject to the following "Limited warranty and Disclaimer" and "Compliance Requirements".

Read and accept them before using the product.

Limited warranty and Disclaimer

1. The warranty period of the product is 1 year in service or 1.5 years after the product is delivered.*2) Also, the product may have specified durability, running distance or replacement parts. Please consult your nearest sales branch.

2. For any failure or damage reported within the warranty period which is clearly our responsibility, a replacement product or necessary parts will be provided. This limited warranty applies only to our product independently, and not to any other damage incurred due to the failure of the product.

3. Prior to using SMC products, please read and understand the warranty terms and disclaimers noted in the specified catalog for the particular products.

***2) Vacuum pads are excluded from this 1 year warranty.**

A vacuum pad is a consumable part, so it is warranted for a year after it is delivered.

Also, even within the warranty period, the wear of a product due to the use of the vacuum pad or failure due to the deterioration of rubber material are not covered by the limited warranty.

Compliance Requirements

1. The use of SMC products with production equipment for the manufacture of weapons of mass destruction (WMD) or any other weapon is strictly prohibited.

2. The exports of SMC products or technology from one country to another are governed by the relevant security laws and regulation of the countries involved in the transaction. Prior to the shipment of a SMC product to another country, assure that all local rules governing that export are known and followed.

1. Operating Precaution

Selection / Design

Warning

1. Confirm the specifications.

This product is designed only for use in compressed air systems (including vacuum).

Do not operate at pressures or temperatures, etc., beyond the range of specifications, as this can cause damage or malfunction. (Refer to the specifications.)

We do not guarantee against any damage if the product is used outside of the specification range.

2. To select equipment first, thoroughly verify the purpose, specification requirements, and the operating conditions such as fluid, pressure, flow rate, temperature, and environment. Then, making sure not to exceed the specification ranges. If handled improperly, leading to unforeseen accidents.

3. Do not use this product for caisson shielding, breathing, medical use, medicine that is injected by humans, or for blowing air on food products.

This product has been designed exclusively for industrial compressed air, and it should not be used for any other purpose.

4. Do not use this product on board a vehicle or a vessel.

This product must not be installed and used on board a conveyance such as a vehicle or a vessel, since it may become damaged due to vibrations.

5. Do not disassemble the product or make any modifications, including additional machining.

It may cause human injury and/or an accident.

6. Do not operate under the conditions listed below due to a risk of malfunction.

- 1) In locations having corrosive gases, organic solvents and chemical solutions, or in locations in which these elements are likely to adhere to the equipment.
- 2) In locations in which sea water, water, or water steam could come in contact with the equipment.
- 3) In locations that are exposed to direct sunlight. (Shield the equipment from sunlight to prevent overheating.)
- 4) In locations that have a heat source and poor ventilation. (Shield the equipment from heat sources to protect it from softening degradation due to radiated heat.)
- 5) In locations that are exposed to shocks and vibrations.
- 6) In locations with high humidity or a large amounts of dust.

Caution

1. The mist separator is not applicable to gases other than compressed air.

The mist separator is not applicable to gases other than compressed air (example: oxygen, hydrogen, Flammable gas, mixed gas).

2. Do not use compressed air that contains chemicals, organic solvents, salt, or corrosive gases.

Do not use compressed gas containing chemicals, organic solvents, salt or corrosive gas. This can cause rust, damage to rubber and resin parts, or malfunction.

Selection / Design

3. Operate within the specified operating pressure range.

Damage, failure, or malfunction may occur if the mist Separator is operated above the maximum operating pressure.

4. Do not introduce an air flow that is greater than the rated flow rate.

If the rated flow rate is exceeded even momentarily, it could cause insufficient moisture elimination or drain or oil splash to the outlet side or lead to equipment damage.

Installation / Piping

Warning

1. Safety measure

The weight of this product is 50kg or more.

Transfer and install this product using the crane etc, to prevent a drop and a fall.

Caution

1. Verify the installation position.

Make sure to install this product on horizontal place.

Design the piping so that a slight taper is provided along the flow to prevent the drain from accumulating.

2. Ensure sufficient space for maintenance activities.

When installing the products, allow access for Maintenance.

3. Verify the IN and OUT sides.

When connecting the piping, avoid interchanging the IN and the OUT sides.

4. Fix the feet to the ground firmly using foundation bolt, etc.

5. Preparation before piping

Use an air blower to thoroughly flush the piping to remove any foreign matter from inside the piping before connecting them.

Operating Precaution

Warning

1. Do not loosen bolts, while pressure is applied.

Before disassembling the equipment on the compressed air side for loosening the bolt, confirm that the pressure is set to zero.

Caution

1. During operation

Confirm that air leakage do not occur.

If an abnormal condition occurs, such as air leakage, Immediately, stop the flow of compressed air and confirm connection of piping, etc.

Maintenance

Warning

1. Perform maintenance inspection according to the procedures indicated in this manual.

If handled improperly, malfunction and damage of machinery or equipment may occur.

2. Maintenance work

If handled improperly, compressed air can be dangerous. Assembly, handling, repair and element replacement of pneumatic systems should be performed by a knowledgeable and experienced person.

3. Removal of equipment, and supply/exhaust of compressed air.

When components are removed, first confirm that measures are in place to prevent workpieces from dropping, run-away equipment, etc. Then, cut off the supply pressure and electric power, and exhaust all compressed air from the system using the residual pressure release function.

4. Set the pressure of the compressed air to zero before an inspection.

Stop the flow of compressed air and confirm that the Pressure is set to zero.

5. Do not touch high temperature areas.

Poses a risk of burns, if the equipment will be used in high-temperature (40~60°C). To prevent burns, confirm that the case and parts (valve, bolt, etc) are 40°C or lower.

6. The adjustment of the safety valve and periodical voluntary inspection of the Class 2 Pressure Vessels are required by the Ordinance on Safety of Boilers and Pressure Vessels. Conduct the inspection according to the mentioned ordinance.

Caution

1. Element replacement

Replace the element immediately when the time for its replacement has arrived.

<The replacement interval for the Element>

The replacement interval for the element is when after one year of operation or the pressure drop reaches 0.1 MPa.

2. Element replacement work

- 1) Perform element replacement work according to the procedures indicated in this manual. If handled improperly, malfunction and damage of machinery or equipment may occur.
- 2) When performing element replacement work, confirm that the pressure is set to zero.
- 3) Install the cover and bolt correctly to specified position, after performing element replacement work.

3. Cleaning of equipment

When replacing the element, clean gasket, cover seat surface and thread for sealing properly.

Maintenance

4. Gasket replacement

Replace the gasket immediately when the time for its Replacement has arrived.

<The replacement interval for the Gasket>

The replacement interval for the gasket is when after one year of operation or when degradation or air leakage occurs.

5. Gasket replacement work

Perform gasket replacement work according to the procedures indicated in this manual as element replacement work.

6. Discharge the drain at least once a day.

Failure to discharge the drain will allow the accumulated drain to flow over to the outlet side.

7. Keep the certificate of Class 2 Pressure Vessel in a safe place.

AFF220A is subject to Class 2 Pressure Vessel Act. Certificate will be sent in 2 to 4 weeks later after the shipment of the product.

2.Construction

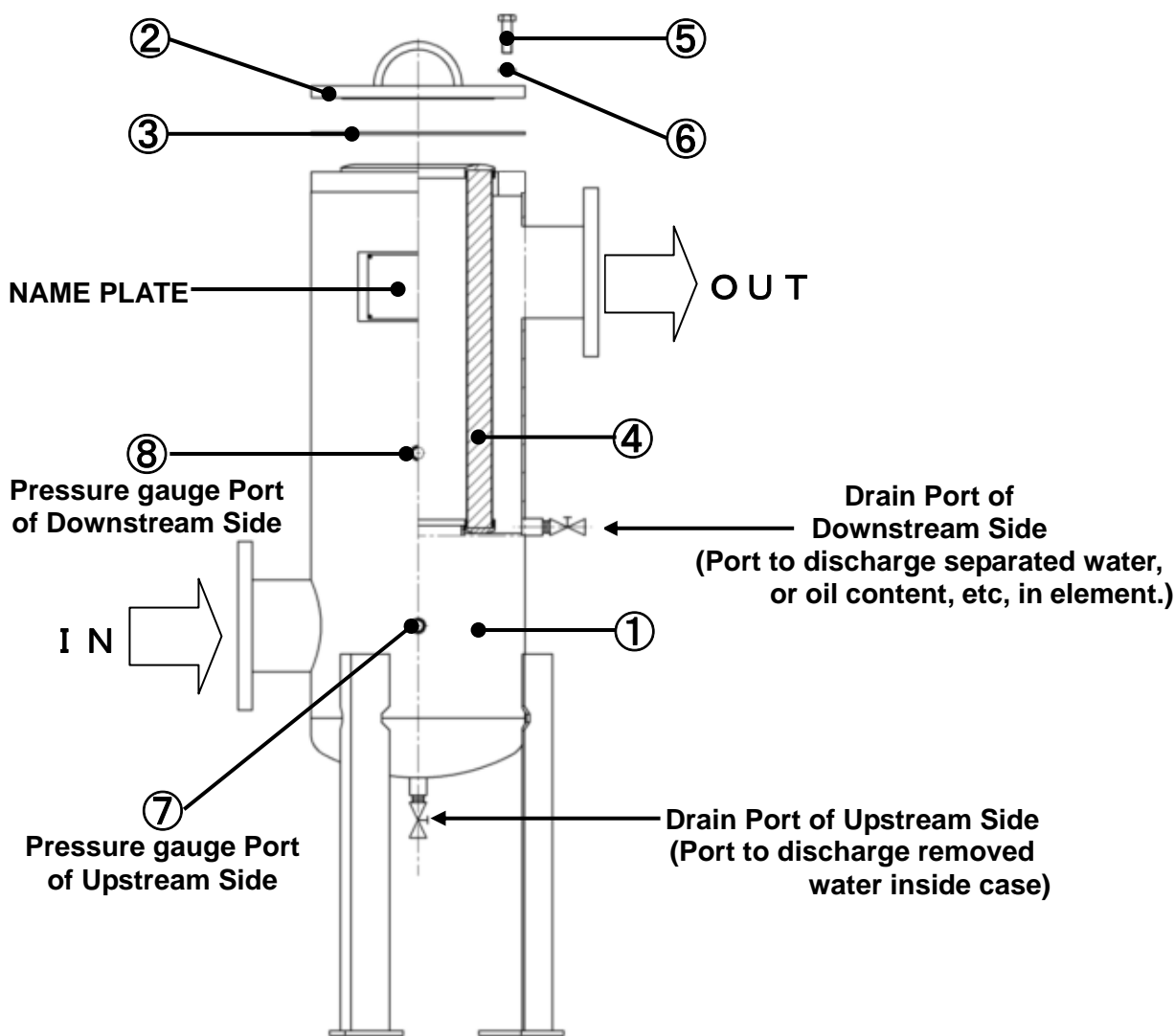

Fig. 1 Construction

Table. 1 Part Name

No.	PART NAME	QTY	MAINTENANCE PART			
			AFF75A	AFF125A	AFF150A	AFF220A
1	CASE	1	—	—	—	—
2	COVER	1	—	—	—	—
3	GASKET	1	AL-33S		AL-34S	AL-35S
4	ELEMENT (for FILTRATION RATING Symbol Nil)	1	EC700-003N		EC800-003N	EC900-003N
	ELEMENT (for FILTRATION RATING Symbol X13)	1	EC700-X30NX0		EC800-X30NX0	EC900-X30NX0
5	HEX.BOLT(M12)	12	—	—	—	—
6	SPRING WASHER	12	—	—	—	—
7	PLUG(1/4)	2	—	—	—	—
8	PLUG(1/4)	2	—	—	—	—

3.Specifications

1) How to Order

AFF **75A** – **20** **D**

Standard size (Applicable compressor)

Symbol	Compressor output
75A	75kW
125A	110~125kW
150A	150kW
220A	180~220kW

Filtration rating of ELEMENT

Symbol	Filtration rating
Nil	3 μm
X13	0.3 μm

Accessory

Symbol	Description
Nil	—
D	Auto drain (Metal bowl type)
P	Auto drain (resin bowl type)
G	Pressure gauge
F	Companion flange
L	Anchor bolt

Port size

Symbol	Size	Applicable body size			
		75A	125A	150A	220A
20	50(2B) JIS 10K FF flange	●	—	—	—
30	80(3B) JIS 10K FF flange	—	●	—	—
40	100(4B) JIS 10K FF flange	—	—	●	●

2) Specifications

Table. 2 Specifications

	Model			
	AFF75A	AFF125A	AFF150A	AFF220A
FLUID	COMPRESSED AIR			
MAX. OPERATING PRESSURE	0.97MPa			
MIN. OPERATING PRESSURE	0.05MPa (With auto drain : 0.1MPa)			
AMBIENT TEMPERATURE	5 to 60°C			
FLUID TEMPERATURE	5 to 60°C			
FLOW RATE (m ³ /min)	12.4	23.7	30	45
CAPACITY (m ³)	0.023	0.023	0.038	0.054
WEIGHT (kg)	50	50	72	88
FILTRATION RATING	3 μm (FILTRATION EFFICIENCY 99%) ※ for FILTRATION RATING Symbol Nil			
	0.3 μm (FILTRATION EFFICIENCY 99%) ※ for FILTRATION RATING Symbol X13			
ELEMENT LIFE	One year or when pressure drop reaches 0.1MPa			

Note) Max.flow at 0.7MPa.

Max.flow varies depending on the operating pressure.

AFF220A is subject to Class 2 Pressure Vessel Act.

⚠ Warning Do not operate at pressures or temperatures, beyond the range of specifications, as this can cause damage or lower its performance.

4. Installation / Piping

1) Installation

Install this product and fix the feet to the ground firmly using foundation bolt, etc.

⚠ Warning The weight of this product is 50kg or more.
Transfer and install this product with a crane, etc, to prevent a drop and a fall.

⚠ Caution When installing and piping the products, allow access for maintenance.
Cover upper (necessary space of element replacement) ... 500mm or more

2) Piping

- Use an air blower to thoroughly flush the piping to remove any foreign matter from inside the piping before connecting them.
- Avoid interchanging the IN and the OUT sides.
- Connect the valves of INLET and OTLET to maintenance.
- The piping of INLET and OUTLET shall be fixed firmly so that load including vibration or weight is not applied to this product.
- Arrange piping so that drain discharging work is available.
Design the piping so that a slight taper is provided along the flow to prevent the drain from accumulating.
- During operation, confirm that air leakage do not occur.

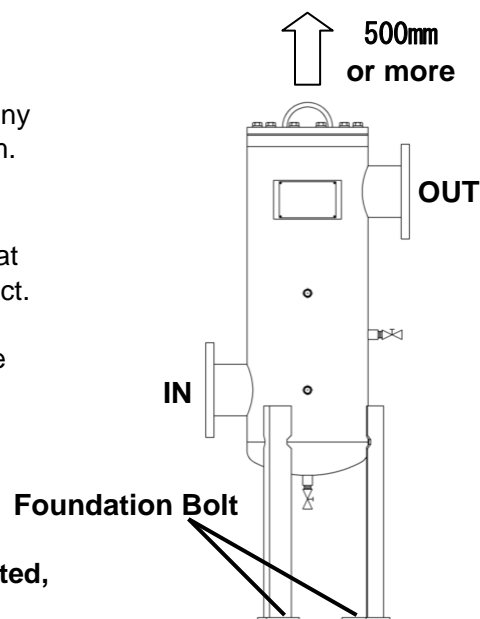

⚠ Caution 1.If the back pressure or back flow are generated, it may damage an element.
2.Failure to discharge the drain will allow the accumulated drain to flow over to the outlet side.

5.Maintenance

1) Daily maintenance

- 1.Open the drain valve and discharge the drain at least once a day.
 Confirm that the auto drain operates in the case of type with auto drain.
- 2.Confirm that air leakage do not occur.

⚠ Caution Failure to discharge the drain will allow the accumulated drain to flow over to the outlet side.

2) Element or Gasket replacement

2-1) The replacement interval for the Element or the Gasket

- | | |
|--|--|
| 【The replacement interval for the Element】 | one year or when pressure drop reaches 0.1MPa |
| 【The replacement interval for the Gasket】 | one year or when degradation or air leakage occurs |
| 【Maintenance part number】 | See Page 6 Table 1 : Part Name |

⚠ Caution Replace the element and the gasket immediately when the time for its replacement has arrived.
 Using the element and the gasket beyond the replacement interval could lower its performance or cause damage of an element.

2-2) Element or Gasket replacement procedure

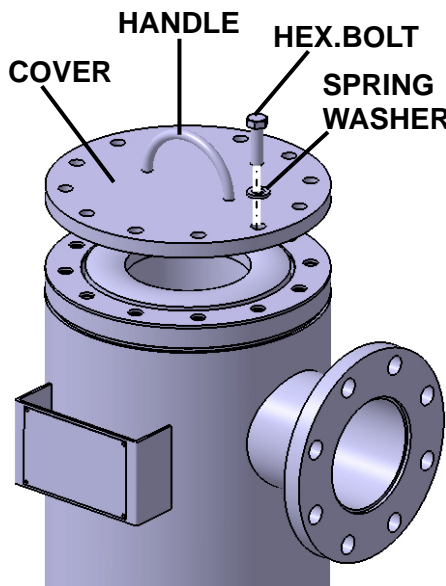
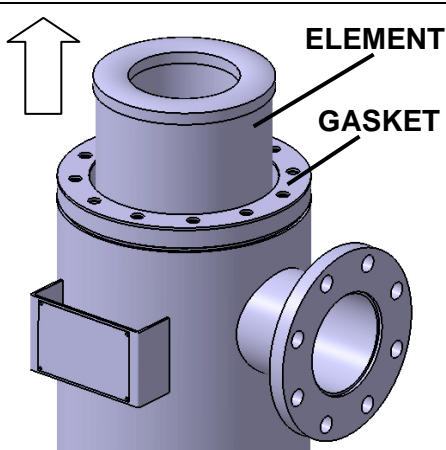
1	【Removal of cover】	
<ol style="list-style-type: none"> 1.Stop the flow of compressed air. 2.Close the valve of INLET, next close the valve of OUTLET. 3.Open the drain valve. 4.Confirm that the pressure is set to zero. 5.Remove the bolt and the washer. (Width across flats : 18mm) 6.Remove the cover, to prevent a drop. <p>⚠ Warning</p> <ol style="list-style-type: none"> 1.When the cover is removed, confirm that the Pressure is set to zero. 2.Confirm that the case and parts are 40°C or lower to prevent burns, if the equipment will be used in high-temperature (40~60°C). 		
2	【Removal of element and gasket】	
<ol style="list-style-type: none"> 1.Pull up the element vertically as show in the figure. 2.Remove the gasket as show in the figure. <p>⚠ Warning</p> <ol style="list-style-type: none"> 1.Confirm that the element are 40°C or lower to prevent burns, if the equipment will be used in high-temperature (40~60°C). 2.Work with gloves because the element contains foreign matter, water, or oil content, etc. 		

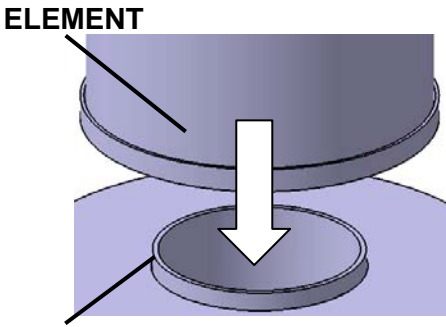
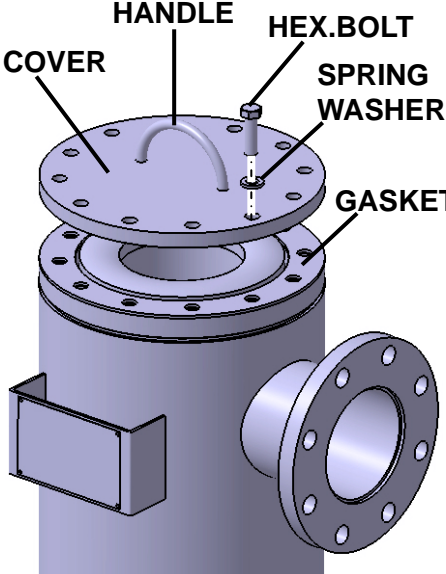
<p>3</p>	<p>【Mounting of the element】</p>	
<p>1.Insert the new element vertically from the top of housing and fit the internal bore of element to the outside of hollow frame.</p> <p>⚠ Caution Confirm that the internal bore of element are fitted to the outside of hollow frame. If handled improperly, it could lower its performance or may damage an element.</p>		
<p>4</p>	<p>【Mount and tighten the gasket and the element】</p>	<p>1.Mount the gasket, and set mounting hole positions. 2.Mount the cover on the gasket, and set mounting hole positions. 3.Install the cover, the washer and the bolt, as show in the figure, and tighten the bolt, to prevent a drop. (Width across flats : 18mm)</p> <p>⚠ Caution During operation, comfirm that air leakage do not occur.</p>

Revision history	
New : 2012/04	The overall revision
Ver.A: 2012/07	P7 Change of How to Order

SMC Corporation URL <http://www.smcworld.com>

4-14-1, Sotokanda, Chiyoda-ku, Tokyo 101-0021 JAPAN

Tel: +81 3 5207 8249 Fax: +81 3 5298 5362

Specifications are subject to change without prior notice and any obligation the part of the manufacturer.

©2012 SMC Corporation All Rights Reserved