



Operation Manual

PRODUCT NAME

Electric Rotary Table

MODEL / Series / Product Number

LER Series



Refer to the manual relevant to the controller being used for full operating instructions.

SMC Corporation

1. Procedure before operation/simple setting to use straight away ...	4
1.1 Preparation	4
2. Electric Rotary Table /LER Series	5
2. 1 LER Series(Basic · External stopper)	5
2.1.1 Specification	5
2.1.2 How to Order.....	6
2.1.3 Construction	7
2. 2 LER Series(Continuous rotation / 360° type)	9
2.2.1 Specification	9
2.2.2 How to Order.....	10
2.2.3 Construction	11
3. Product Outline	12
3.1 System construction	12
3.2 Step data setting method	14
Positioning operation	14
Pushing operation.....	16
Operating procedure and input / output signals for each operation.....	22
Continuous rotation / 360° type setting	23
3.3 Parameter setting method.....	24
Initial setting for the basic parameters	24
Initial setting for the ORIG parameters	25
4. Wiring of cables / Common precautions	26
5. Electric actuators / Common precautions	27
5.1 Design and selection	27
5.2 Mounting.....	28
5.3 Handling	29
5.4 Operating environment	30
5.5 Maintenance	31
5.6 Precautions for actuator with lock	31
6. Electric Rotary Table /Specific Product Precautions	32
6.1 Design and selection	32
6.2 Mounting.....	32
6.3 Handling	33
6.4 Maintenance	34
7. Troubleshooting	35



Electric Actuator / Rotary Table Safety Instructions

These safety instructions are intended to prevent hazardous situations and/or equipment damage. These instructions indicate the level of potential hazard with the labels of “**Caution**,” “**Warning**” or “**Danger**.” They are all important notes for safety and must be followed in addition to International Standards (ISO/IEC)^{*1)}, and other safety regulations.

*1) ISO 4414: Pneumatic fluid power - General rules and safety requirements for systems and their components
ISO 4413: Hydraulic fluid power - General rules and safety requirements for systems and their components
IEC 60204-1: Safety of machinery - Electrical equipment of machines - Part 1: General requirements
ISO 10218-1: Robots and robotic devices - Safety requirements for industrial robots - Part 1: Robots
etc.



Danger

Danger indicates a hazard with a high level of risk which, if not avoided, will result in death or serious injury.

Warning

Warning indicates a hazard with a medium level of risk which, if not avoided, could result in death or serious injury.

Caution

Caution indicates a hazard with a low level of risk which, if not avoided, could result in minor or moderate injury.



Warning

1. The compatibility of the product is the responsibility of the person who designs the equipment or decides its specifications.

Since the product specified here is used under various operating conditions, its compatibility with specific equipment must be decided by the person who designs the equipment or decides its specifications based on necessary analysis and test results. The expected performance and safety assurance of the equipment will be the responsibility of the person who has determined its compatibility with the product. This person should also continuously review all specifications of the product referring to its latest catalog information, with a view to giving due consideration to any possibility of equipment failure when configuring the equipment.

2. Only personnel with appropriate training should operate machinery and equipment.

The product specified here may become unsafe if handled incorrectly. The assembly, operation and maintenance of machines or equipment including our products must be performed by an operator who is appropriately trained and experienced.

3. Do not service or attempt to remove product and machinery/equipment until safety is confirmed.

1. The inspection and maintenance of machinery/equipment should only be performed after measures to prevent falling or runaway of the driven objects have been confirmed.
2. When the product is to be removed, confirm that the safety measures as mentioned above are implemented and the power from any appropriate source is cut, and read and understand the specific product precautions of all relevant products carefully.
3. Before machinery/equipment is restarted, take measures to prevent unexpected operation and malfunction.

4. SMC products cannot be used beyond their specifications. They are not developed, designed, and manufactured to be used under the following conditions or environments. Use under such conditions or environments is not allowed.

1. Conditions and environments outside of the given specifications, or use outdoors or in a place exposed to direct sunlight.
2. Use for nuclear power, railways, aviation, space equipment, ships, vehicles, military application, equipment affecting human life, body, and property, combustion equipment, entertainment equipment, emergency shut-off circuits, press clutches, brake circuits, safety equipment, etc., and use for applications that do not conform to standard specifications such as catalogs and operation manuals.
3. Use for interlock circuits, except for use with double interlock such as installing a mechanical protection function in case of failure. Please periodically inspect the product to confirm that the product is operating properly.



Electric Actuator / Rotary Table Safety Instructions

Caution

SMC develops, designs, and manufactures products to be used for automatic control equipment, and provides them for peaceful use in manufacturing industries.

Use in non-manufacturing industries is not allowed.

Products SMC manufactures and sells cannot be used for the purpose of transactions or certification specified in the Measurement Act of each country.

The new Measurement Act prohibits use of any unit other than SI units in Japan.

Limited warranty and Disclaimer/Compliance Requirements

The product used is subject to the following "Limited warranty and Disclaimer" and "Compliance Requirements". Read and accept them before using the product.

Limited warranty and Disclaimer

1. The warranty period of the product is 1 year in service or 1.5 years after the product is delivered, whichever is first.*2)
Also, the product may have specified durability, running distance or replacement parts. Please consult your nearest sales branch.
2. For any failure or damage reported within the warranty period which is clearly our responsibility, a replacement product or necessary parts will be provided.
This limited warranty applies only to our product independently, and not to any other damage incurred due to the failure of the product.
3. Prior to using SMC products, please read and understand the warranty terms and disclaimers noted in the specified catalog for the particular products.

***2) Vacuum pads are excluded from this 1 year warranty.**

A vacuum pad is a consumable part, so it is warranted for a year after it is delivered.

Also, even within the warranty period, the wear of a product due to the use of the vacuum pad or failure due to the deterioration of rubber material are not covered by the limited warranty

Compliance Requirements

1. The use of SMC products with production equipment for the manufacture of weapons of mass destruction (WMD) or any other weapon is strictly prohibited.
2. The exports of SMC products or technology from one country to another are governed by the relevant security laws and regulations of the countries involved in the transaction. Prior to the shipment of a SMC product to another country, assure that all local rules governing that export are known and followed.

1. Procedure before operation/simple setting to use straight away

The controller is already set with the data of the actuator.

With the simple setting “easy mode”, it can be operated and running parameters can be changed easily.

1.1 Preparation

(1) Items to be prepared

Please check on the label, and the quantity of accessories, to confirm that it is the product that was ordered.

Table 1. Componets

No.	Part name	Option	Qty
(1)	Electric Rotary Table		1
(2)	Controller		1
(3)	Power supply plug		1
(4)	Actuator cable		1
(5)	I/O cable (Not use in this section)		1
(6)	Teaching box		1
(7)	Controller setting kit [The controller setting software, The communication cable, USB cable and conversion unit are included.] Setting software / version 1.1 or higher		1

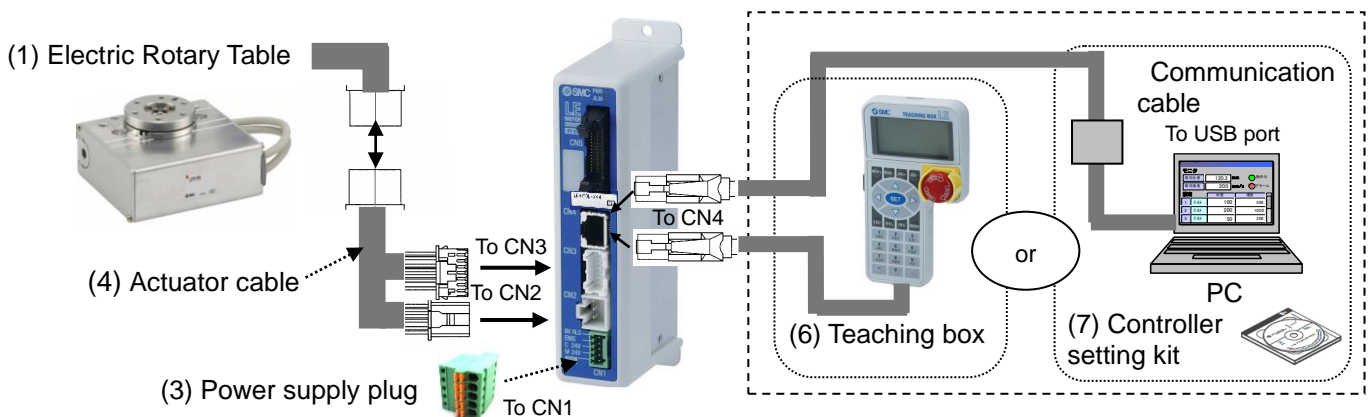
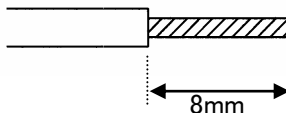
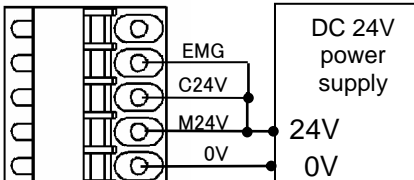

Table 2. Items to be prepared by the customer

Part name	Conditions
Power supply 24VDC Except “inrush-current restraining type”	Refer to power consumption of each actuator
Wire AWG20 (0.5mm ²)	Stripped wire length 
Power supply plug Wiring	<p>Connect the plus side of DC 24V to the C24V, M24V and EMG terminals of the power supply plug, and the minus side to the 0V terminal. When conformity to UL is required, the electric actuator and controller should be used with a UL1310 Class 2 power supply.</p> <p>Push the open/ close lever and insert the wire into the electrical wire entry.</p>  <p>Electrical wire entry</p>

2. Electric Rotary Table /LER Series

2.1 LER Series(Basic · External stopper)

2.1.1 Specification

Model		LER*10K	LER*10J	LER*30K	LER*30J	LER*50K	LER*50J	
Rotation Angle (°)		310		320				
Gear rate(°)		8	12	8	12	7.5	12	
Max. Rotation Torque(N·m)		0.32	0.22	1.2	0.8	10.0	6.6	
Pushing Torque 40~50%(N·m) ^{Note 1) Note 3)}		0.13~0.16	0.09~0.11	0.48~0.60	0.32~0.40	4.0~5.0	2.6~3.3	
Max. Moment of Inertia(kg·m ²) ^{Note 2)}	LECP6/1/MJ/JXC9	0.004	0.0018	0.035	0.015	0.13	0.05	
	LECPA			0.027	0.012	0.10	0.04	
Rotation Speed(°/sec) ^{Note 2) Note 3)}		20to280	30to420	20to280	30to420	20to280	30to420	
Pushing Speed(°/sec)		20	30	20	30	20	30	
Angular acceleration/ Angular deceleration(°/sec ²) ^{Note 2)}		3,000						
Backlash(°)	Basic	± 0.3		± 0.2				
	High precision							± 0.1
Repeatability (°)	Basic	± 0.05		± 0.05				
	High precision							± 0.03
Lost motion (°) ^{Note 4)}	Basic	0.3 or less		0.3 or less				
	High precision							0.2 or less
Impact resistance/vibration resistance (m/sec ²) ^{Note 5)}		150/30						
Actuation type		Worm gear and belt						
Table allowable load	Radial load (N)	Basic	78	196	314			
		High precision	86	233	378			
	Thrust load /Push(N)	Basic	78	363	451			
		High precision	107	398	517			
	Thrust load /Pull(N)	Basic	74	197	296			
		High precision						
	Moment (N·m)	Basic	2.4	5.3	9.7			
		High precision	2.9	6.4	12.0			
Max. operating frequency(c.p.m)		60						
Operating temperature range (°C)		5 to 40						
Operating humidity range (%RH)		90 or less (No condensation)						
Weight (kg)	Basic	0.49	1.1	2.2				
	High precision	0.52	1.2	2.4				
External stopper	Rotation Angle (°)	(-2) with 1 Arm	180					
		(-3) with 2 Arms	90					
	Repeatability at the end (°)		±0.01					
	Range of external stopper(°)		±2					
	Weight (kg)	(-2) with 1 Arm	Basic	0.55	1.2	2.5		
			High precision	0.61	1.4	2.7		
(-3) with 2 Arms		Basic	0.57	1.2	2.6			
		High precision	0.63	1.4	2.8			
Motor size		□20		□28		□42		
Motor		Step motor (Servo 24VDC)						
Encoder (Angular displacement sensor)		Incremental A/B phase (800 pulse/rotation)						
Rated voltage(VDC)		24 ± 10%						
Power consumption(W) ^{Note 6)}		11		22		34		
Standby power consumption when operating(W) ^{Note 7)}		7		12		13		
Max.instantaneous power consumption(W) ^{Note 8)}		19		42		57		

Note 1) Pushing Torque accuracy should be ±30%(F.S.) for LER10, ±25%(F.S.) for LER30, ±20%(F.S.) for LER50.

Note 2) The Angular acceleration, angular deceleration and angular speed may fluctuate due to variations in the moment of inertia. Refer to the catalog.

Note 3) The speed and force may change depending on the cable length, load and mounting conditions. Furthermore, if the cable length exceeds 5m then it will decrease by up to 10% for each 5m. (At 15m : Reduced by up to 20%)

Note 4) A reference value for correcting an error in reciprocal operation.

Note 5) Impact resistance: No malfunction occurred when the rotary actuator was tested with a drop tester in both an axial direction and a perpendicular direction to the lead screw. (The test was performed with the rotary actuator in the initial state)

Vibration resistance: No malfunction occurred in a test ranging between 45 to 2000 Hz. Test was performed in both an axial direction and a perpendicular direction to the lead screw.

(The test was performed with the rotary actuator in the initial state)

Note 6) The "Power consumption" (including the controller) is for when the actuator is operating.

Note 7) The "Standby power consumption when operating" (including the controller) is for when the actuator is stopped in the set position during the operation, except for during the pushing operation.

Note 8) The "Momentary max.power consumption" (including the controller) is for when the actuator is operating.

This value can be used for the selection of the power supply.

2.1.2 How to Order

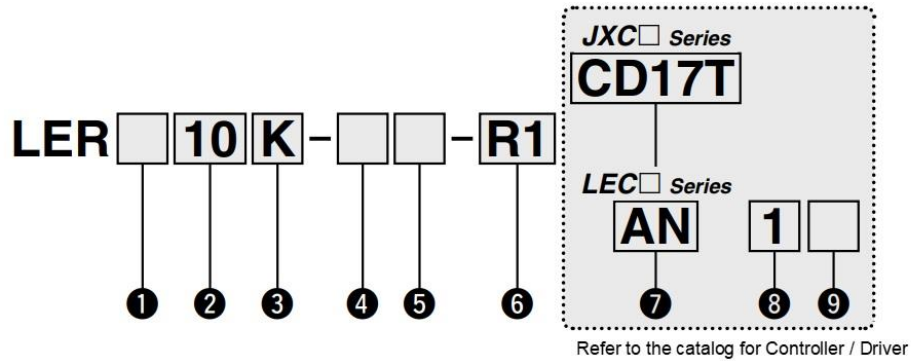

1 Table accuracy

Nil	Basic type
H	High-precision type

2 Size

10
30
50

3 Max. rotating torque [N·m]

Symbol	Type	LER10	LER30	LER50
K	High torque	0.32	1.2	10
J	Basic	0.22	0.8	6.6

4 Rotation angle [°]

Symbol	LER10	LER30	LER50
Nil	310	320	
2	External stopper: 180		
3	External stopper: 90		

5 Motor cable entry

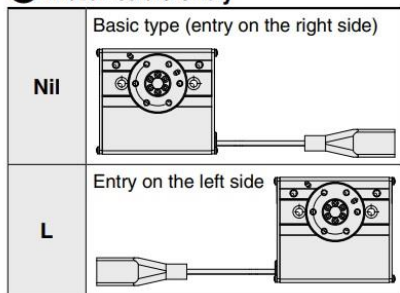

6 Actuator cable type/length*2

Standard cable [m]		Robotic cable [m]			
Nil	None	R1	1.5	RA	10*1
S1	1.5	R3	3	RB	15*1
S3	3	R5	5	RC	20*1
S5	5	R8	8*1		

*1 Produced upon receipt of order (Robotic cable only)

*2 The standard cable should only be used on fixed parts.

For use on moving parts, select the robotic cable.

⚠ Caution

The actuator body and controller are sold as a package.

If When only the actuator is purchased separately, confirm that the combination of the controller, which you have and the actuator is compatible. / See 5.3 ⚠ Caution (1) on p. 36

<Be sure to check the following before use.>

- (1) Check that actuator label for model number.
This matches the controller.
- (2) Check Parallel I/O configuration matches (NPN or PNP).

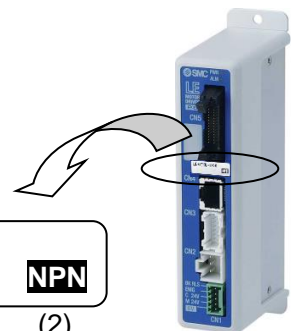
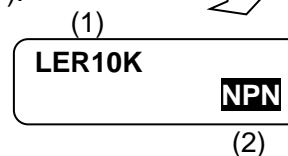

2.1.3 Construction

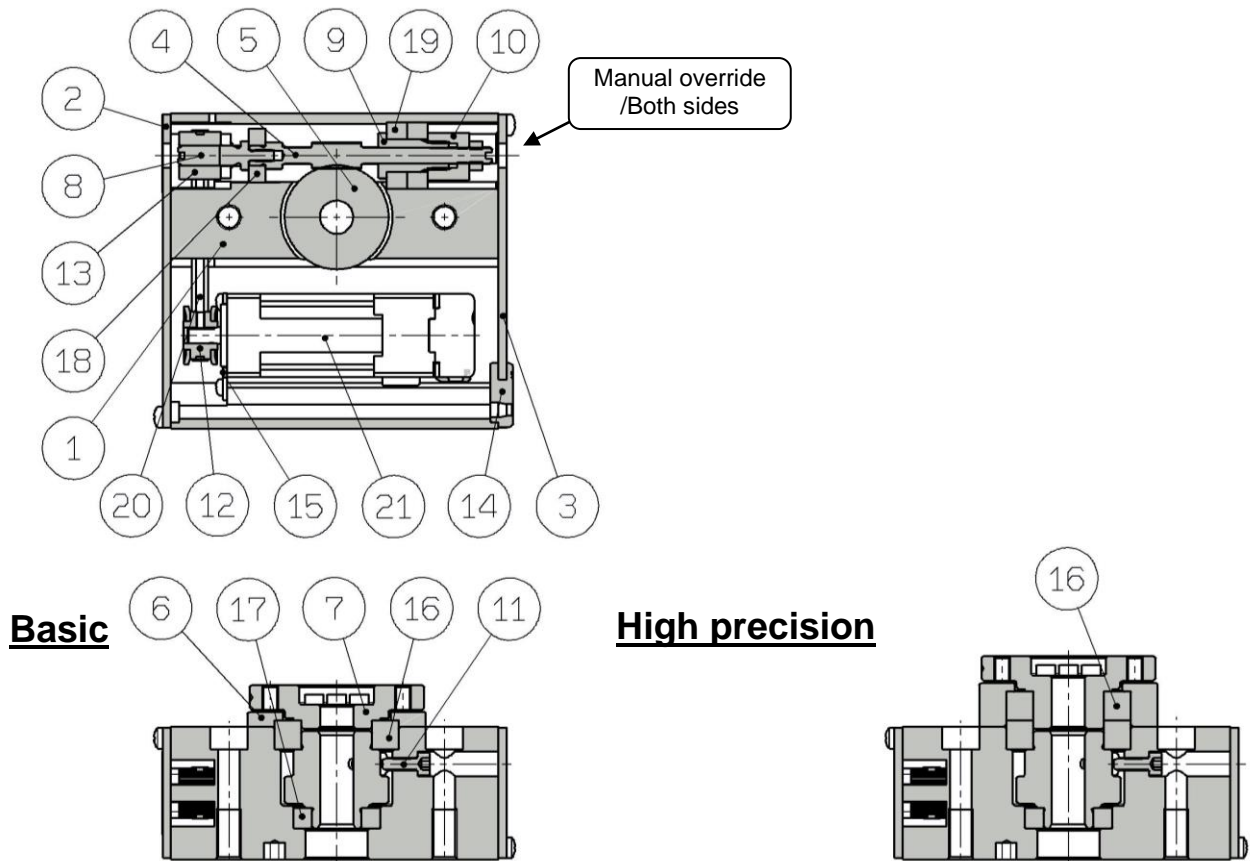

Parts list

No.	Part	Material	Remarks
1	Body	Aluminium alloy	Anodized
2	Side plate A	Aluminium alloy	Anodized
3	Side plate B	Aluminium alloy	Anodized
4	Worm screw	Stainless steel	Heat treated, Specially treated
5	Worm wheel	Stainless steel	Heat treated, Specially treated
6	Bearing cover	Aluminium alloy	Anodized
7	Table	Aluminium alloy	Anodized
8	Joint	Stainless steel	
9	Bearing holder	Aluminium alloy	
10	Bearing retainer	Aluminium alloy	
11	Starting point bolt	Carbon steel	
12	Pulley A	Aluminium alloy	
13	Pulley B	Aluminium alloy	
14	Grommet	NBR	
15	Motor plate	Carbon steel	
16	Basic	Deep groove ball bearing	-
	High precision	Special ball bearing	-
17	Deep groove ball bearing	-	
18	Deep groove ball bearing	-	
19	Deep groove ball bearing	-	
20	Belt	-	
21	Step motor (Servo/24VDC)	-	

External stopper

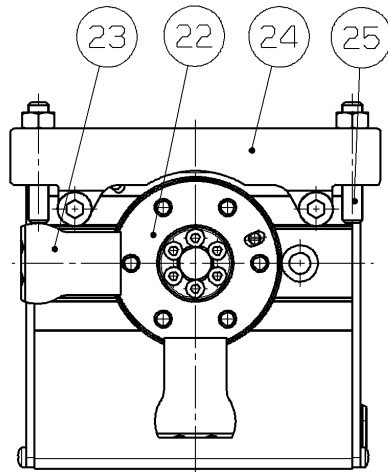

Parts list

No.	Part	Material	Remarks
22	Table	Aluminium alloy	Anodized
23	Arm	Carbon steel	Nickel plated
24	Holder	Aluminium alloy	Anodized
25	Adjustment bolt	Carbon steel	Chromating

2.2 LER Series(Continuous rotation / 360° type)

2.2.1 Specification

Model		LER*10K	LER*10J	LER*30K	LER*30J	LER*50K	LER*50J	
Actuator specification / 360° type	Rotation Angle (°) ^{Note 9)}	360						
	Angle range (°) ^{Note 9)}	±20000000						
	Max. Rotation Torque(N·m)	0.32	0.22	1.2	0.8	10.0	6.6	
	Pushing Torque 40~50%(N·m) ^{Note 1) Note 3)}	0.13~0.16	0.09~0.11	0.48~0.60	0.32~0.40	4.0~5.0	2.6~3.3	
	Max. Moment of Inertia(kg·m ²) ^{Note 2)}	0.004	0.0018	0.035	0.015	0.13	0.05	
	Rotation Speed(°/sec) ^{Note 2) Note 3)}	20to280	30to420	20to280	30to420	20to280	30to420	
	Pushing Speed(°/sec)	20	30	20	30	20	30	
	Angular acceleration/ Angular deceleration(°/sec ²) ^{Note 2)}	3,000						
	Backlash(°)	Basic	± 0.3			± 0.2		
		High precision				± 0.1		
	Repeatability (°)	Basic	± 0.05			± 0.05		
		High precision				± 0.03		
	Lost motion (°) ^{Note 4)}	Basic	0.3 or less			0.3 or less		
		High precision				0.2 or less		
	Impact resistance/vibration resistance (m/sec ²) ^{Note 5)}	150/30						
	Actuation type	Worm gear and belt						
	Table allowable load	Radial load (N)	Basic	78	196	314		
			High precision	86	233	378		
		Thrust load /Push(N)	Basic	78	363	451		
			High precision	107	398	517		
Thrust load /Pull(N)		Basic	74	197	296			
		High precision						
Moment (N·m)	Basic	2.4	5.3	9.7				
	High precision	2.9	6.4	12.0				
Max. operating frequency(c.p.m)	60							
Operating temperature range (°C)	5 to 40							
Operating humidity range (%RH)	90 or less (No condensation)							
Weight (kg)	Basic	0.51	1.2	2.3				
	High precision	0.55	1.3	2.5				
Electric specification	Motor size	□20	□28	□42				
	Motor	Step motor (Servo 24VDC)						
	Encoder (Angular displacement sensor)	Incremental A/B phase (800 pulse/rotation)						
	Proximity sensor (for Return to original position)/ Input circuit	2 wire						
	Proximity sensor (for Return to original position)/ Input number	1 outputs						
	Rated voltage(VDC)	24 ± 10%						
	Power consumption(W) ^{Note 6)}	11	22	34				
	Standby power consumption when operating(W) ^{Note 7)}	7	12	13				
	Max.instantaneous power consumption(W) ^{Note 8)}	19	42	57				

Note 1) Pushing Torque accuracy should be ±30%(F.S.) for LER10, ±25%(F.S.) for LER30, ±20%(F.S.) for LER50.

Note 2) The Angular acceleration, angular deceleration and angular speed may fluctuate due to variations in the moment of inertia. Refer to the catalog.

Note 3) The speed and force may change depending on the cable length, load and mounting conditions. Furthermore, if the cable length exceeds 5m then it will decrease by up to 10% for each 5m.(At 15m : Reduced by up to 20%)

Note 4) A reference value for correcting an error in reciprocal operation.

Note 5) Impact resistance: No malfunction occurred when the rotary actuator was tested with a drop tester in both an axial direction and a perpendicular direction to the lead screw.

(The test was performed with the rotary actuator in the initial state)

Vibration resistance: No malfunction occurred in a test ranging between 45 to 2000 Hz. Test was performed in both an axial direction and a perpendicular direction to the lead screw.

(The test was performed with the rotary actuator in the initial state)

Note 6) The "Power consumption" (including the controller) is for when the actuator is operating.

Note 7) The "Standby power consumption when operating" (including the controller) is for when the actuator is stopped in the set position during the operation, except for during the pushing operation.

Note 8) The "Momentary max.power consumption" (including the controller) is for when the actuator is operating. This value can be used for the selection of the power supply.

Note 9) The Monitor angle is reset to 0° every 360°. Select INC (Relative) for setting the angle (position).

If setting the angle above 360° with ABS (Absolute), the actuator will not operate correctly.

2.2.2 How to Order

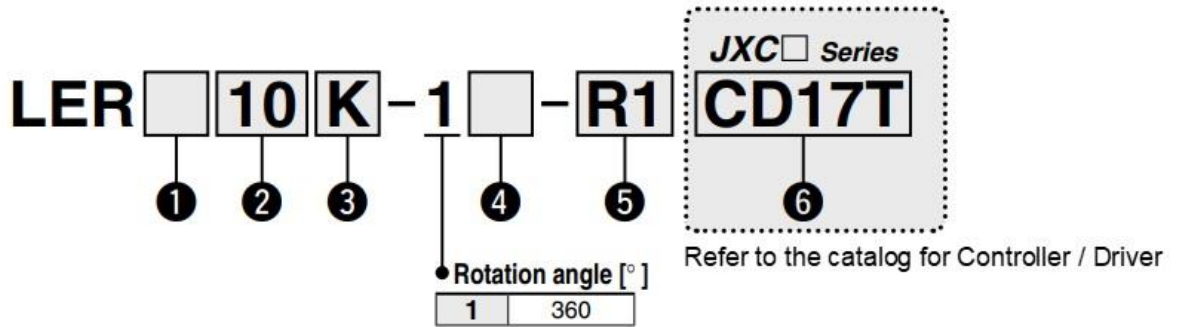

1 Table accuracy

Nil	Basic type
H	High-precision type

2 Size

10
30
50

3 Max. rotating torque [N·m]

Symbol	Type	LER10	LER30	LER50
K	High torque	0.32	1.2	10
J	Basic	0.22	0.8	6.6

4 Motor cable entry

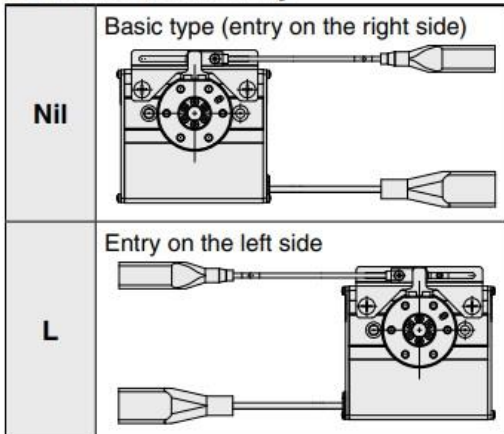

5 Actuator cable type/length*1 *3

Standard cable [m]		Robotic cable [m]			
Nil	None	R1	1.5	RA	10*2
S1	1.5	R3	3	RB	15*2
S3	3	R5	5	RC	20*2
S5	5	R8	8*2		

- *1 The actuator cable is equipped with a lock and sensor.
- *2 Produced upon receipt of order (Robotic cable only)
- *3 The standard cable should only be used on fixed parts.
For use on moving parts, select the robotic cable.

⚠ Caution

The actuator body and controller are sold as a package.

If When only the actuator is purchased separately, confirm that the combination of the controller, which you have and the actuator is compatible. / See 5.3 ⚠ Caution (1) on p. 36

<Be sure to check the following before use.>

- (3) Check that actuator label for model number.
This matches the controller.
- (4) Check Parallel I/O configuration matches (NPN or PNP).

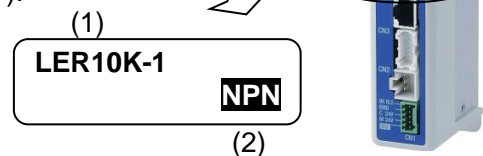

2.2.3 Construction

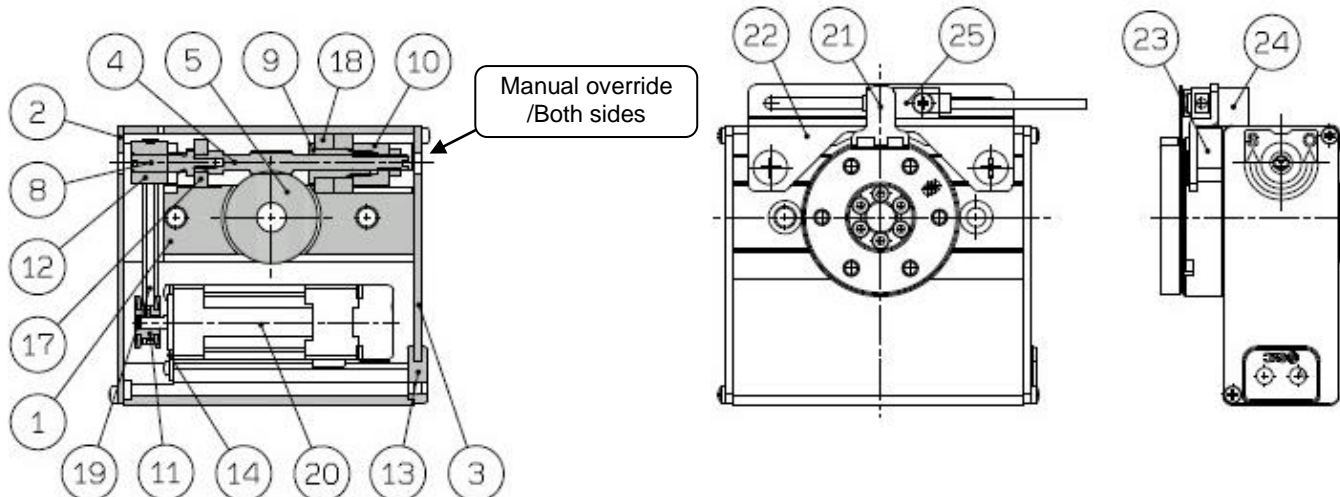

Basic

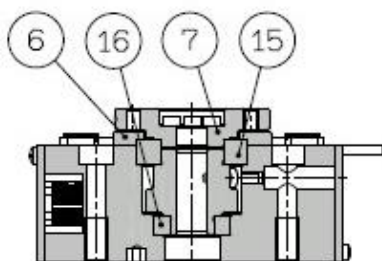

High precision

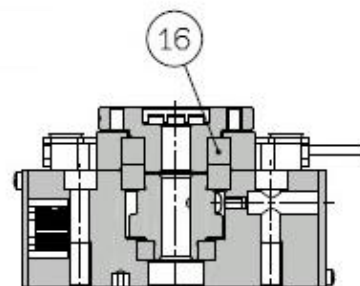

Parts list

No.	Part	Material	Remarks
1	Body	Aluminium alloy	Anodized
2	Side plate A	Aluminium alloy	Anodized
3	Side plate B	Aluminium alloy	Anodized
4	Worm screw	Stainless steel	Heat treated, Specially treated
5	Worm wheel	Stainless steel	Heat treated, Specially treated
6	Bearing cover	Aluminium alloy	Anodized
7	Table	Aluminium alloy	Anodized
8	Joint	Stainless steel	
9	Bearing holder	Aluminium alloy	
10	Bearing retainer	Aluminium alloy	
11	Pulley A	Aluminium alloy	
12	Pulley B	Aluminium alloy	
13	Grommet	NBR	
14	Motor plate	Carbon steel	
15	Basic Deep groove ball bearing	-	
	High precision Special ball bearing	-	
16	Deep groove ball bearing	-	
17	Deep groove ball bearing	-	
18	Deep groove ball bearing	-	
19	Belt	-	
20	Step motor (Servo/24VDC)	-	
21	Proximity dog	Stainless steel	
22	Sensor holder	Carbon steel	Chromating
23	Sensor holder spacer	Aluminium alloy	Anodized (high precision type only)
24	Square nut	Aluminium alloy	
25	Proximity sensor assembly	-	

3. Product Outline

3.1 System construction

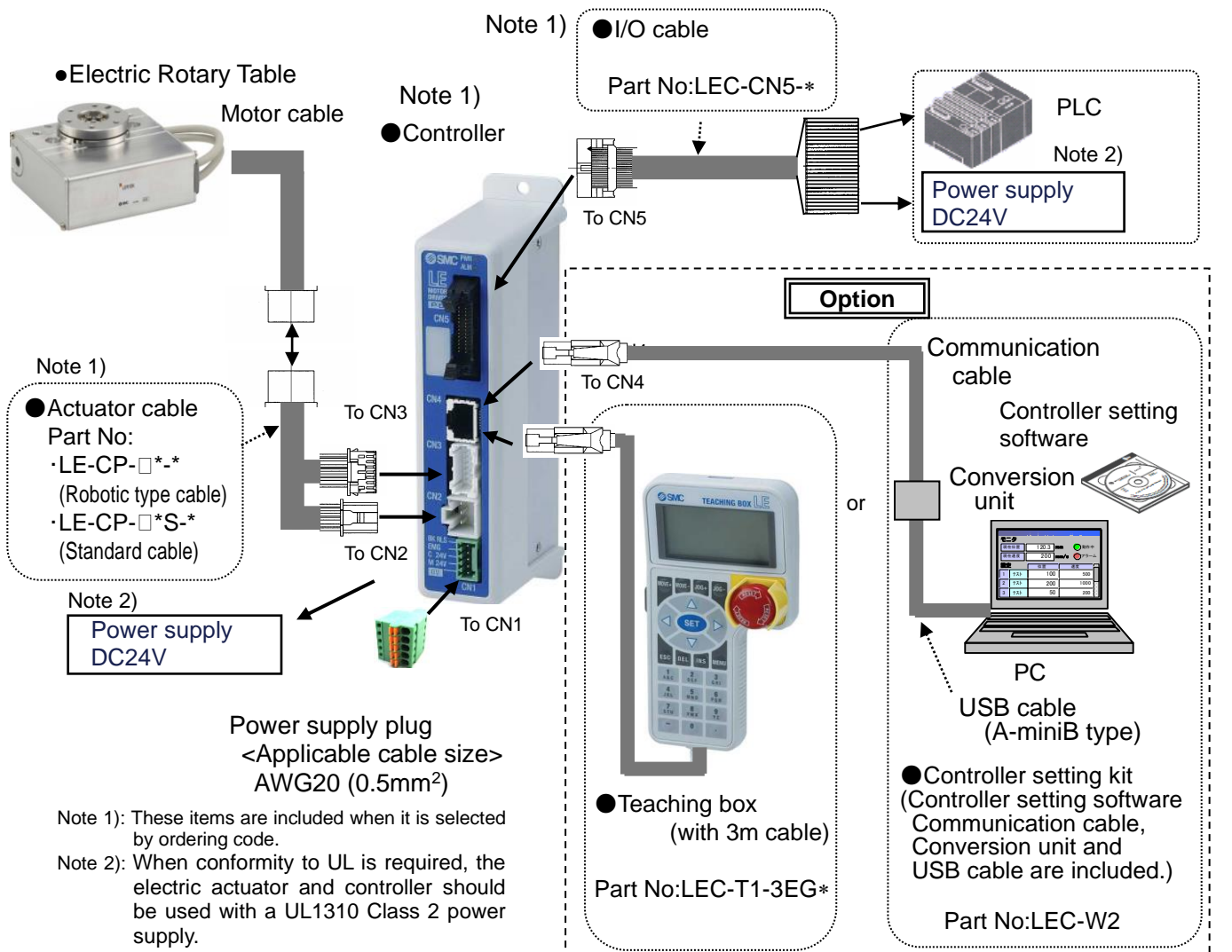

※ When the controller setting software/version is below 1.1, the display unit is distance (mm), but the product recognizes it as an angle (°). To upgrade the software, please go to the operation manual page of the SMC website. <http://www.smcworld.com/>

Warning

Refer to the operation manual of the LEC (controller) for detailed wiring.
/See 4 Wiring of cables on p.29.

Communication cable is to be connected to PC by USB cable through conversion unit.
And do not connect teaching box to PC.

Use only specified cables otherwise there maybe fire risk and damage.

The actuator body and controller are sold as a package.

If When only the actuator is purchased seperately, confirm that the combination of the controller, which you have and the actuator is compatible.

/ See 5.3 ⚠ Caution (1) on p. 36

<Be sure to check the following before use.>

- (1) Check that actuator label for model number.
This matches the controller.
- (2) Check Parallel I/O configuration matches (NPN or PNP).

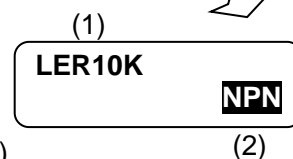

Controlled items

PC: Controller setting software

TB: Teaching box

O: Available function

X: Not available function

Function		Content	Easy mode		Normal mode
			PC	TB	PC/TB
Step data (Except)	Movement method	Can be selected of absolute / relative position move	○	×	○
	Speed	Can be set in units of 1°/s.	○	○	○
	Position	Can be set in units of 0.01°.	○	○	○
	Acceleration Deceleration	Can be set in units of 1°/s ² .	○	○	○
	Pushing force	Can be set in units of 1%. / In case of positioning operation: Set to 0%.	○	○	○
	Trigger LV	Trigger LV of target pushing force when pushing operation: Can be set in units of 1%.	○	×	○
	Pushing speed	Can be set in units of 1°/s.	○	×	○
	Moving force	100%	○	×	○
	Area output	Can be set in units of 0.01°.	○	×	○
In position	During positioning operation: Width to the target position. It should be set to 0.5° or more. During pushing operation: How much it moves during pushing.	○	×	○	
Parameter (Except)	Stroke(+)	+ side limit of position. (Can be set in units of 0.01°)	×	×	○
	Stroke(-)	- side limit of position. (Can be set in units of 0.01°).	×	×	○
	ORIG direction	Direction of the return to the original position can be set	×	×	○
	ORIG speed	Speed when returning to the original position can be set.	×	×	○
	ORIG ACC	Acceleration when returning to origin can be set.	×	×	○
Test	JOG	It can make continuous operation at the set speed while the switch is being pressed	○	○	○
	MOVE	It can make test operation at the set distance and speed from the current position when the switch is pressed.	○	×	○
	Return to ORIG	Test of return to origin can be done.	○	○	○
	Test drive	The operation of the specified step data can be tested.	○	○	○ (Continuous operation)
	Force output	ON/OFF of the output terminal can be tested.	×	×	○
Monitor	DRV mon	Current position, current speed, current force and the specified step data No. can be monitored.	○	○	○
	In/Out mon	Current ON/OFF status of the input and output terminal can be monitored.	×	×	○
ALM	Status	The alarm currently being generated can be confirmed, and be reset.	○	○	○
	ALM Log record	The alarm generated in the past can be confirmed.	×	×	○
File	Save - Load	The step data and parameter of the objective controller can be saved, forwarded and deleted.	×	×	○
Other	Language	Language can be changed to Japanese / English.	○ *3	○ *2	○ *2 *3

*1 Every parameter is set to the recommended condition before shipment from the factory. Only change the setting of the items which require adjustment.

*2 Teaching box: In the Normal mode the teaching box can be set to work in English or Japanese.

*3 Controller setting software: Can be installed by selecting English version or Japanese version.

3.2 Step data setting method

Refer to the operation manual of the controller (LEC series) for details.

This operation manual specifies the electric rotary actuator, if an actuator other than the electric rotary actuator is used, refer to the operation manual of each type of actuator and controller (LEC series) regarding the description of step data.

Caution

The actuator body and controller are sold as a package.

If When only the actuator is purchased separately, confirm that the combination of the controller, which you have and the actuator is compatible. / See 5.3  Caution (1) on p. 36

<Be sure to check the following before use.>

- (1) Check that actuator label for model number.
This matches the controller.
- (2) Check Parallel I/O configuration matches (NPN or PNP).

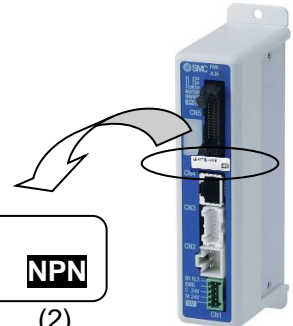
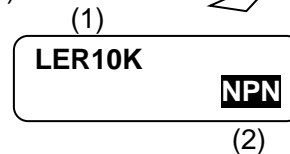

Positioning operation

In the positioning operation, the electric rotary actuator moves to and stops at the target position. The following image shows the setting items and operation.

<Confirmation of reaching the target position during the positioning operation>

When the table of the rotary actuator reaches the range of the target position, the “target position reaching signal” 【INP】 (in position) is outputted.

When the table of the rotary actuator enters the range of 【In position】, the INP output signal turns on.

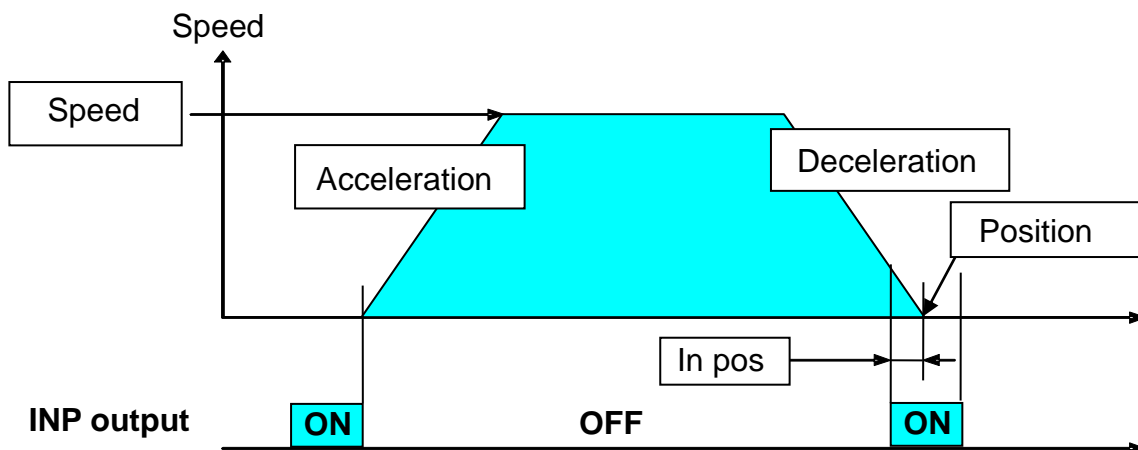



Caution

When the table is to be stopped by an external object, utilize the “pushing operation”.

If the product is used in the positioning operation, there may be galling or other problems when it comes into contact with the external object.

Note) When it is not possible to operate the table, move it with manual override screws.

/ See 6.2  Caution (5) on p. 40
and 6.3  Caution (4) on p. 40

<Items and set values in positioning operation>

Step No. 0: Positioning operation

	a	b	c	d	e	f	g	h	i	j		k
No.	Move M	Speed	Position	Acce l	Decel	PushingF	TriggerLV	PushingSp	MovingF	Area1	Area2	In pos
		° /s	°	° /s ²	° /s ²	%	%	° /s	%	°	°	°
0	ABS	200	0.00	3000	3000	0	0	0	100	20.00	40.00	0.50
1	ABS	200	180.00	3000	3000	50	50	30	100	179.00	181.00	5.00

【◎】 Need to be set · 【○】Need to be adjusted as required

【X】 Not used. Items don't need to be changed in positioning operation.

a <◎ Movement MOD> When the absolute position is required, set Absolute
When the relative position is required, set Relative
⇒ Absolute: Distance from the origin position. / General setting method
Relative: Feed from the current position. / This is used when simplified data.

b <◎ Speed> Transfer speed to the target position.

c <◎ Position> Target position.

d <○ Acceleration> The parameter which defines how rapidly the actuator reaches the speed set in **b**
The higher the set value, the faster it reaches the speed set in **b**.

e <○ Deceleration> The parameter which defines how rapidly the actuator comes to stop.
The higher the set value, the quicker it stops.

f <◎ Pushing force> Set **0**. (If values other than 0 set, the operation will be changed to the pushing operation.)

g <X Trigger LV> **h** <X Pushing speed>

i <○ Moving force> Max. force at the positioning operation.
The force is automatically adjusted corresponding to the load.
/See 6.3▲Caution (2) on p. 40

j <○ Area1, Area2> This is the condition that turns on the AREA output signal.
The setting condition should be **Area 1<Area 2**.
It is possible to set at Relative operation too.
The position will be Absolute (position from the origin).

Example) In case of Step no.0

【AREA】 output signal is outputted between Area 1:20 and Area 2:40.

k <○ In position> This is the condition that turns on the INP (in position) output signal.
⇒ When the electric rotary actuator reaches the range of the target position, the INP output signal is output.
When the electric actuator enters the range of [in position], the INP output signal turns on.
When it is necessary to output the target position reaching signal earlier, make the value larger.

Note) Default: Set the value more than 【0.50】.

Example) In case of Step no.0

Position: 0 + In position: 0.5 = 【INP】 is outputted from the value of 0.5.

Pushing operation

The table move to the target position and hold a work piece with the set pushing force.
The figure shows setting items and operation. The setting items and values are described below.

< Confirmation of reaching the target value during the pushing operation >

The “target position reaching signal” INP (in position) is generated when the target pushing force (Trigger LV) is achieved.

Also, if the actual pushing force exceeds the Trigger LV, the INP signal is turned on.

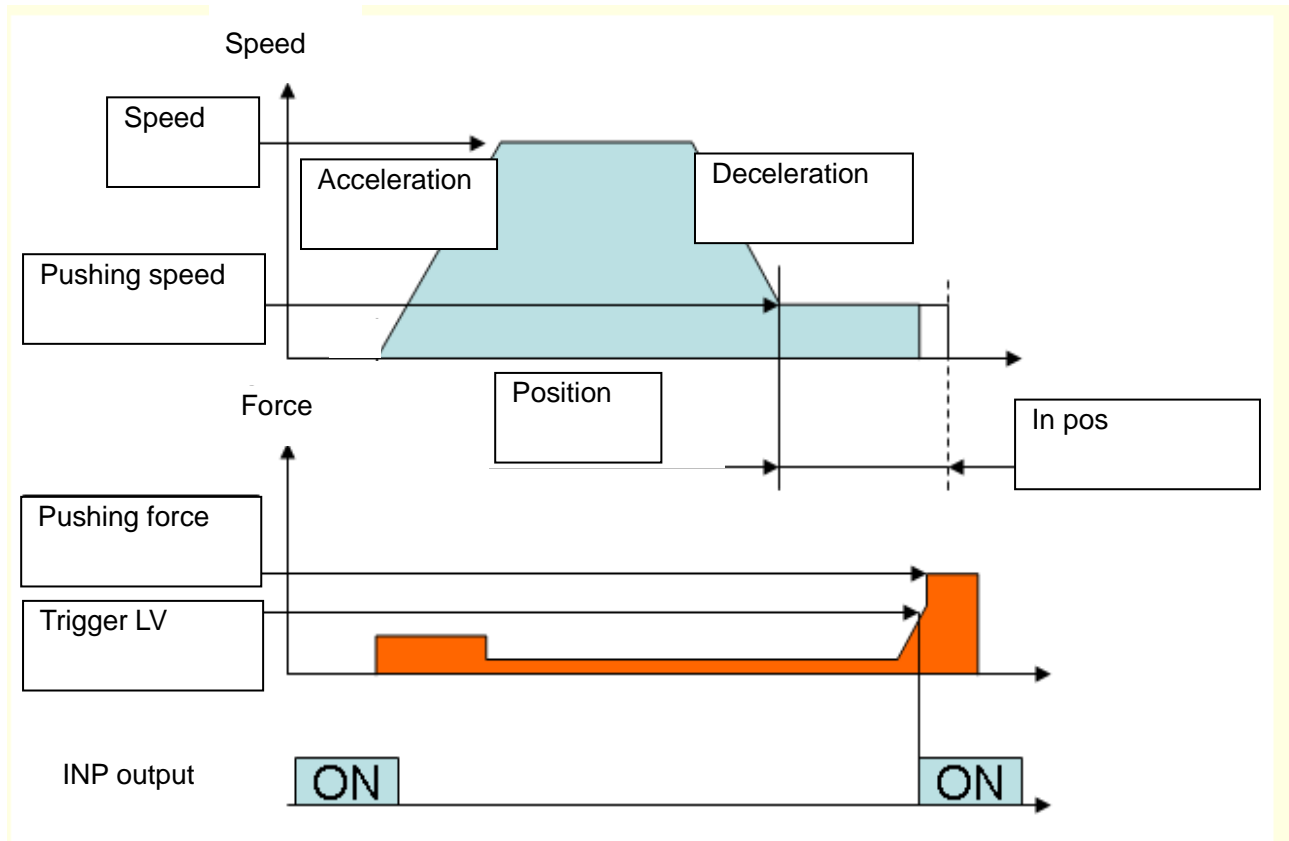



Caution

When the table is to be stopped by an external object, utilize the “pushing operation”.

If the product is used in the positioning operation, there may be galling or other problems when it comes into contact with the external object.

Note) When it is not possible to operate the table, move it with manual override screws.

/ See 6.2  Caution (5) on p. 40
and 6.3  Caution (4) on p. 40

<Items and setting values of pushing operation>

Step no. 1: Pushing operation

No.	Move M	Speed °/s	Position °	Acce °/s ²	Decel °/s ²	PushingF %	TriggerLV %	PushingSp °/s	MovingF %	Area1 °	Area2 °	In pos °
0	ABS	200	0.00	3000	3000	0	0	0	100	20.00	40.00	0.50
1	ABS	200	180.00	3000	3000	50	50	30	100	179.00	181.00	5.00

【◎】 Need to be set · 【○】 Need to be adjusted as required

a <◎ Movement MOD> When the absolute position is required, set Absolute
When the relative position is required, set Relative
⇒ Absolute : Distance from the origin position.
Relative : Feed from the current position

b <◎ Speed> Transferring speed to the target position.

c <◎ Position> Target position.

Note) When the table is to be stopped by an external object, set the product to a position of at least 1 degrees away from the work piece. (This position is referred to as the pushing start position). / See 6.3 ⚠ Caution (5) on p. 41

d <○ Acceleration> The parameter which defines how rapidly the actuator reaches the speed set in **b**
The higher the set value, the faster it reaches the speed set in **b**.

e <○ Deceleration> The parameter which defines how rapidly the actuator comes to stop.
The higher the set value, the quicker it stops.

f <◎ Pushing force> Pushing force ratio is defined. Note) 40% to 50%

g <◎ Trigger LV> The condition at which INP output signal is turned on.
Set it at the value equivalent to **the pushing force**
/ See 6.3 ⚠ Caution (3) on p. 40
⇒ The INP output signal is given when the target force (Trigger LV) is achieved.
The INP output signal is turned on when the generated force exceeds the value.

h <◎ Pushing speed> The pushing speed
⇒ Set the speed in the following range. If the speed is too high, the actuator or workpiece can be damaged by the impact.
Note) LER*K series: 20 °/sec , LER*J series: 30 °/sec

i <○ Moving force> The upper force limit for the pushing operation starting position.
The force is automatically adjusted corresponding to the load.
/ See 6.3 ⚠ Caution (2) on p. 40

j <○ Area1, Area2> This is the condition that turns on the AREA output signal.
The setting condition should be **Area 1<Area 2**.
It is possible to set at Relative operation.
The position will be Absolute (position from the origin).

k <◎ In position> The transfer distance (relative value) when pushing
If the transferred distance exceeds the setting, it stops even if it is not pushing.
If the transfer distance is exceeded, the INP output signal will not be turned on.
(incomplete pushing)

Example) In case of Step no.1

Position: 180 + positioning width: 5 = 185 (The position where the incomplete pushing is detected.)

Example of step data entry (1)

< Positioning operation - 【INP】output signal, 【AREA】output signal >

	a	b	c	d	e	f	g	h	i	j		k
No.	Move M	Speed	Position	Accel	Decel	PushingF	TriggerLV	PushingSp	MovingF	Area1	Area2	In pos
		°/s	°	°/s ²	°/s ²	%	%	°/s	%	°	°	°
0	ABS	200	0.00	3000	3000	0	0	0	100	20.00	40.00	0.50

• **Step data no.0 : Positioning operation (It moves from Position:180[°] to Position:0[°])**

Condition 1) The 【AREA】output signal is not used.

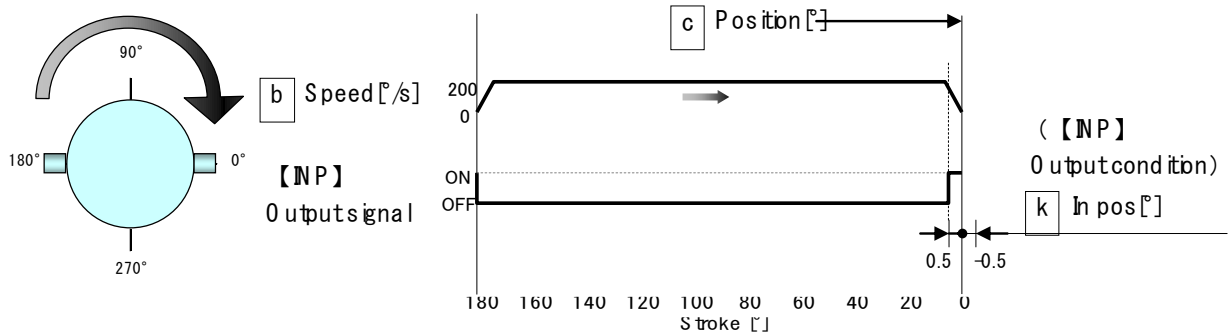

The 【INP】output signal is turned on from $0[°] + 0.5[°] = 0.5[°]$

Condition 2) The 【AREA】output signal is used.

*The 【AREA】output signal is a signal output when the rod traverses through a certain range (The step data: **Area 2** from **Area 1**).

This feature is useful when an output to check the rod position at intermediate stroke is required.

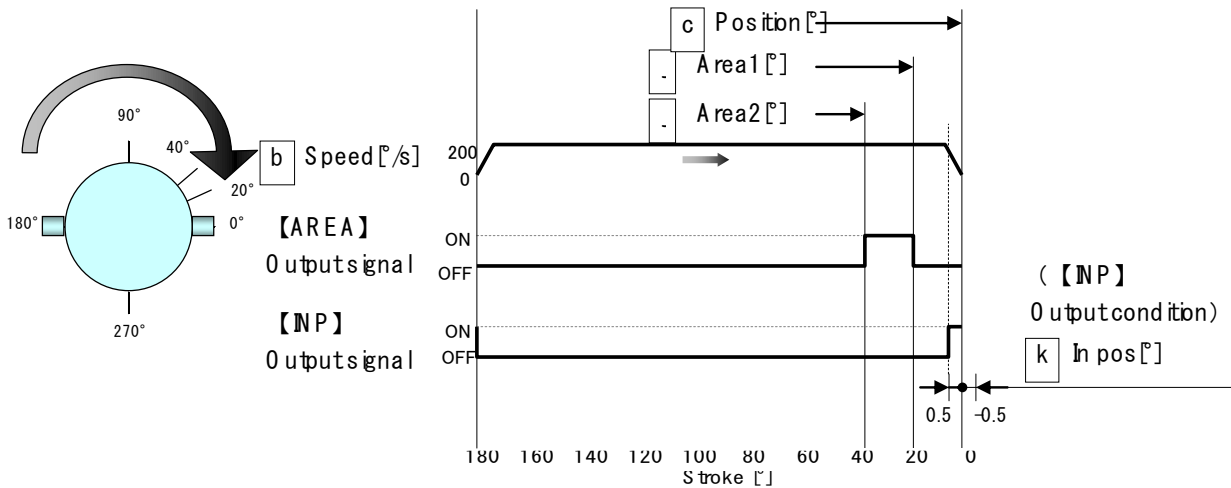

- The 【AREA】output signal is turned on from **Area 1:20[°]** between **Area 2:40[°]**.
- The 【INP】output signal is turned on from $0[°] + 0.5[°] = 0.5[°]$

Example of step data entry (2)

< Pushing operation - 【INP】output signal, 【AREA】output signal >

	a	b	c	d	e	f	g	h	i	j	k	
No.	Move M	Speed	Position	Accel	Decel	PushingF	TriggerLV	PushingSp	MovingF	Area1	Area2	In pos
		°/s	°	°/s ²	°/s ²	%	%	°/s	%	°	°	°
0	ABS	200	40.00	3000	3000	50	40	30	100	0.00	60.00	50.00

Step data no.0 : Positioning operation. (It moves to End limit after it moves from 180° to 40°.)

Condition 1) The 【AREA】output signal is not used.

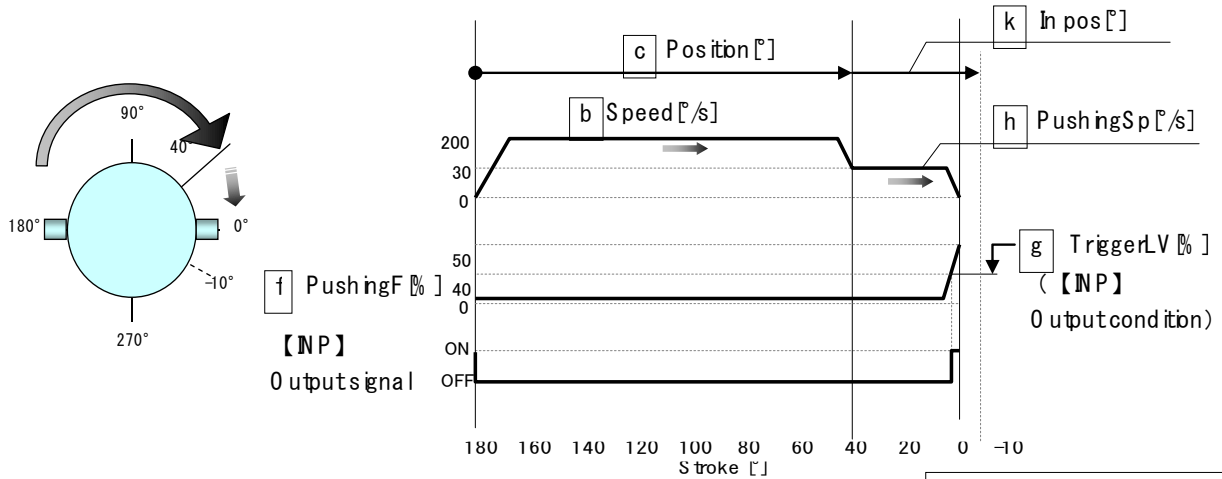

• The 【INP】output signal is turned on when trigger LV : 40[%] is exceeded.

/See 6.3⚠caution(3) on p.36

Condition 2) The 【AREA】output signal is used.

* The 【AREA】output signal is a signal output when the rod traverses through a certain range (The step data: **Area 2** from **Area 1**).

This feature is useful when an output to check the rod position at intermediate stroke is required.

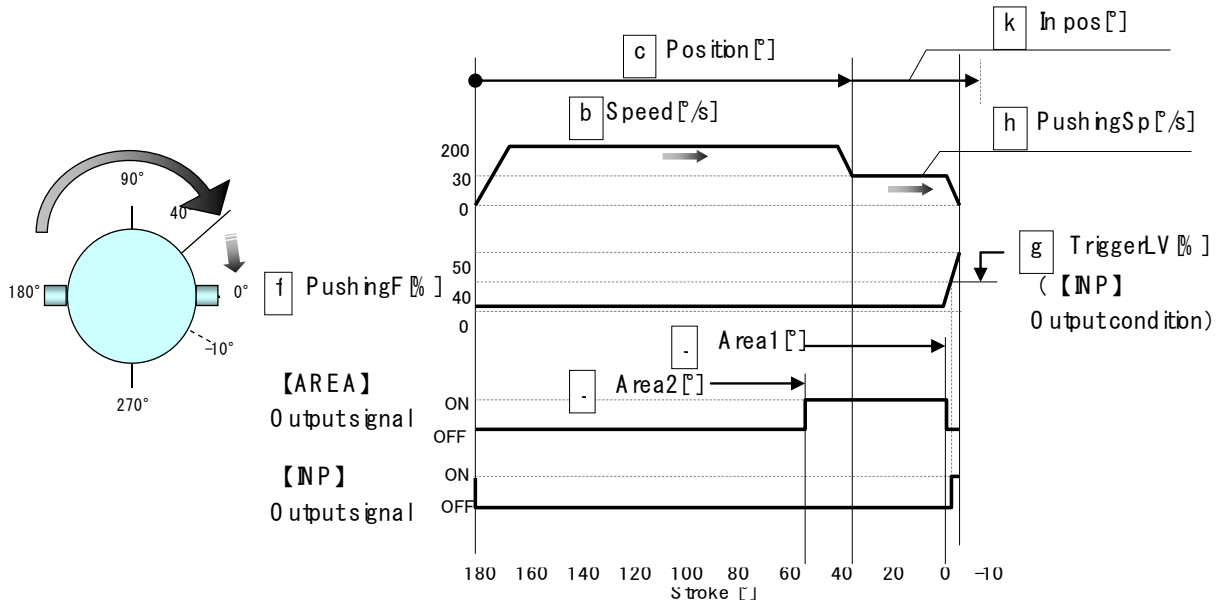

• The 【AREA】output signal is turned on from **Area 1:0[°]** between **Area 2:60[°]**.

• The 【INP】output signal is turned on when trigger LV : 40[%] is exceeded.

Example of step data entry (3)

< Pushing operation - In position >

No.	Move M	Speed °/s	Position °	Accel °/s ²	Decel °/s ²	PushingF %	TriggerLV %	PushingSp °/s	MovingF %	Area1 °	Area2 °	In pos °
0	ABS	200	60.00	3000	3000	50	40	30	100	20.00	60.00	40.00

•Step data no.0 : Pushing operation

("Pushing operation" is done during 40° after it moves from 100° to 60°.)

Condition 1) Length to work < In position

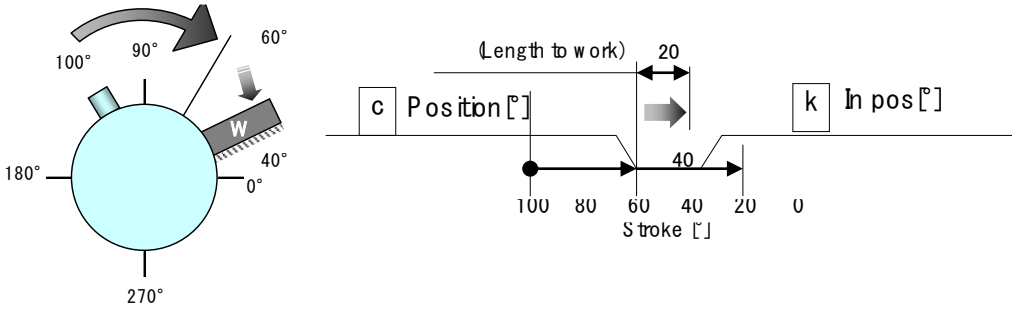

【INP】Output condition

- **k** In pos \geq Length to work
- Actual force \geq **g** TriggerLV



The 【INP】 output signal is turned on

Condition 2) Length to work > In position

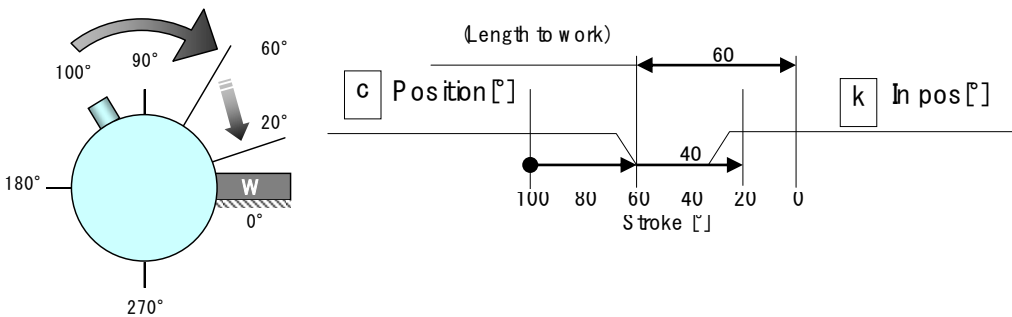

【INP】Output condition

- **k** In pos < Length to work
- Actual force < **g** TriggerLV

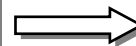

The 【INP】 output signal is not turned on
The 【BUSY】 output signal is turned on

Example of step data entry (4)

< Pushing operation – Driving starting position >

The pushing action is different and dependent upon the starting position and direction.

Confirm the position where the pushing operation starts.

No.	Move M	Speed ° /s	Position °	Accel ° /s ²	Decel ° /s ²	PushingF %	TriggerLV %	PushingSp ° /s	MovingF %	Area1 °	Area2 °	In_pos °
0	ABS	200	100.00	3000	3000	0	0	0	100	0.00	0.00	0.50
1	ABS	200	0.00	3000	3000	0	0	0	100	0.00	0.00	0.50
2	ABS	200	40.00	3000	3000	50	40	30	100	20.00	40.00	20.00

Condition 1) In case the pushing operation is to **Step no.2**.

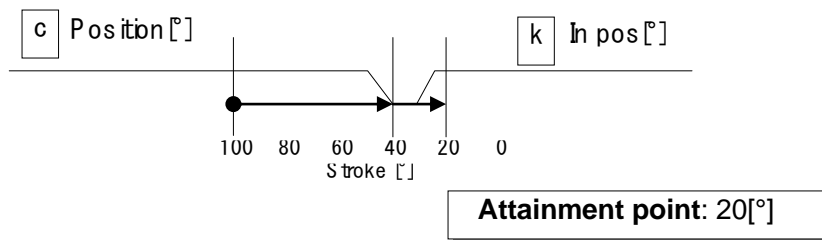
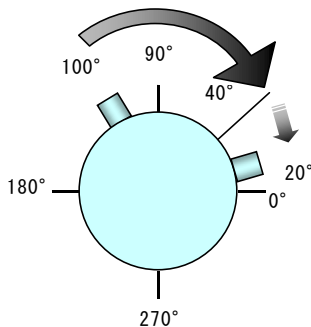

Condition 2) In case the pushing operation is to **Step no.2**.

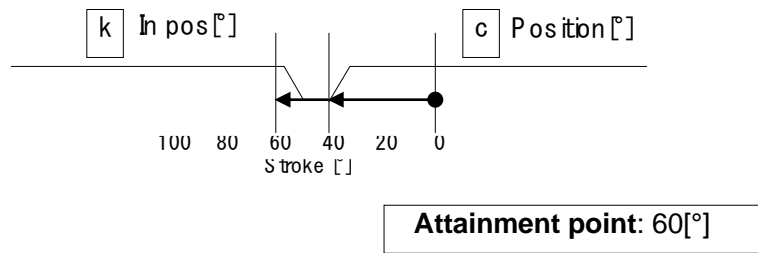
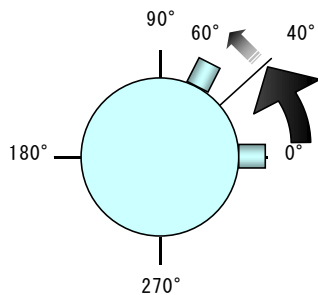

Caution

When the operation is discontinued by EMG-Stop or drive-stop

Drive-stop and the pushing operation is commanded just after restart, the moving direction depends on the operation-starting position.

Operating procedure and input / output signals for each operation.

The input / output signal and the operation description for operating this electric actuator are as follows.

1) Signals along with the operation procedures

In case the operation order is

1. Supply power to the motor → 2. Return to origin → 3. Step no. 1 → 4. Step no. 2 → 5. Cut power to the motor

Procedure	Input signal	Output signal to the input signal	Operation description
1	SVON (Servo on) [●]	SVRE (Servo ready) [●]	Power is supplied to the motor, and detection of the magnetic pole position starts. => Completion.
2	SETUP [●]	SETON [●] INP (IN position) [●]	Returning to the origin starts. =>Completion.
3	IN0 [●] IN1 [] IN2 [] IN3 [] IN4 [] IN5 [] ↓ DRIVE [●]⇒[](Note 3) 5)	OUT0 [●] OUT1 [] OUT2 [] OUT3 [] OUT4 [] OUT5 [] } Note 3)4) ↓ After reaching of target position, INP [●] After stopping motion, BUSY []	Step no. 1 is selected, and the operation starts. ⇒ Complete.
4	IN0 [] IN1 [●] IN2 [] IN3 [] IN4 [] IN5 [] ↓ DRIVE [●]⇒[](Note 3) 5)	OUT0 [] OUT1 [●] OUT2 [] OUT3 [] OUT4 [] OUT5 [] } Note 3)4) ↓ After reaching of target position, INP [●] After stopping motion, BUSY []	Select the step no. 2, and the operation starts. ⇒ Complete.
5	SVON []	SVRE [] SETON [●] Note 2) INP [●]	Power to the motor is cut.

Note 1) [●] means ON, [] means OFF.

Note 2) The origin has been recognized when the operation is repeated, so it can operate without the procedure item 2.

Note 3) The "OUT*" signals are reset during the rising edge of the Drive signal. The "OUT*" signal which follows the "IN*" signal are outputted at the falling edge of the "drive" signal.

Note 4) When the alarm is generated, the alarm group is displayed.
Please confirm the controller (LEC series) manual for a detailed content of the alarm.

Note 5) Leave an interval of 15ms (the recommendation is 30ms) or more between input signals and maintain the state of the signal for 15ms (the recommendation is 30ms) or more, because PLC processing delays and controller scanning delays can occur.

2) Signals when stopped: In the event when “EMG” is used

The operating sequence is **1. “Stop”** → **2. Release the “Stop”**

Procedure	Input signal	Output signal for the input signal	Operation description
1	EMG: Not energizing (TB / Stop switch: Locking)	* ESTOP[] SVRE [] SETON [●]	Power to the motor is cut by the “Stop” command regardless of whether it is operating or stopping.
2	EMG: Energizing (TB / Stop switch: Releasing)	* ESTOP[●] SVRE [●] SETON [●] Note 2)	The stop is released.

Note 1) [●] means ON, [] means OFF. * means negative logic

Note 2) SETON signal does not change after releasing the “STOP”.

Note 3) If the stop is input from the EMG or RESET terminal or the stop-switch on the connected Teaching Box during pushing operation, the actuator stop. (“Busy” signal turns OFF) And if the actuator stop within the range of “Position” ± “In pos” defined in step data, output signal “INP” turns ON.

Continuous rotation / 360° type setting

1) Precautions for setting Continuous rotation / 360° type

(1) The Monitor angle will be reset to 0° every 360°.

(2) Select Relative for setting the angle (position).

If the setting angle is over 360° with ABS (Absolute), the actuator will not operate correctly.

(3) Please set the range of output signal “Area” to 0°-359.99°.

2) The actuator stopped in the middle of the stroke due to emergency stop or alarm.

If Relative is selected in the next step, movement to the correct position will not be available.

Restart operation after moving back to 0° position using the procedure below.

3) Setting range of continuous rotation

If the set range of continuous rotation exceeds +/-9999.99°, use the controller kit (LEC-W2). Teaching box (LEC-T1) has a limit for the display angle.

(1) Controller setting kit / LEC-W2

Relative method ±20000000.00° (Approx. 55555 rotations)

(2) Teaching box / LEC-T1

Relative method ±9999.99° (Approx. 27 rotations)

4) Setting method of continuous rotating.

Following is setting of three continuous rotation without stopping.

Movement MOD [Relative] / [Position] 1080°

Moreover, when output signal “Area” is set, the signal will output three times in three rotations because of the signal setting range 0°-359.99°.

3.3 Parameter setting method

Initial setting for the basic parameters

Refer to the controller's (LEC series) operation manual for detail.

As the "basic parameter" is unique data of each actuator, if an actuator other than the rotary actuator is used, refer to the operation manual of each actuator and the controller's (LEC series) operation manual for the basic parameter.

Description (Extract)	Initial input value	Input range
Controller ID	1	1 to 64 Note 1)
IO pattern	1: 64	-
ACC/ DCC pattern	1:Trapezoid - motion	-
S-motion rate	0	-
Stroke (+)	1000.00 / Basic ,External stopper(-2,3) 10000000.00 /360°type(-1)	-
Stroke (-)	-1000.00 / Basic ,External stopper(-2,3) -10000000.00 /360°type(-1)	-
Max speed	Max. speed of each product	Step data input limit: Max. speed of each product
Max ACC / DCC	3,000	Step data input limit: 3,000 at the maximum
Def In position	0.50	-
ORIG offset	0.00 / Basic,360°type(-1) 5.00/ External stopper(-2,3)	-
Max force	50	Step data input limit: 40 to 50
Para protect	1:Common+StepDate	Changeable parameter 1: Common + StepData, 2: Common
Enable SW	2: Disable	Select 1:Enable or 2:Disable when using a teaching box
Unit name	Part no. of each product	Only the English characters and numbers are changeable.
W-AREA1	0.00	-
W- AREA2	0.00	-
ORIG Correct	0.00	-
Sensor type	1	-
Option set1	0	-
Undefined parameter 11	0	-
Undefined parameter 12	0	-

Note1) Become effective after restarting the controller.

<Return to origin>

Before the positioning and pushing operation, "return to origin" is necessary to establish the origin. The current position value of the electric rotary table increases if the "S" to "O" direction (move in the CW direction). (The table moving direction to be increased cannot be changed.)

1) Flow of return to origin

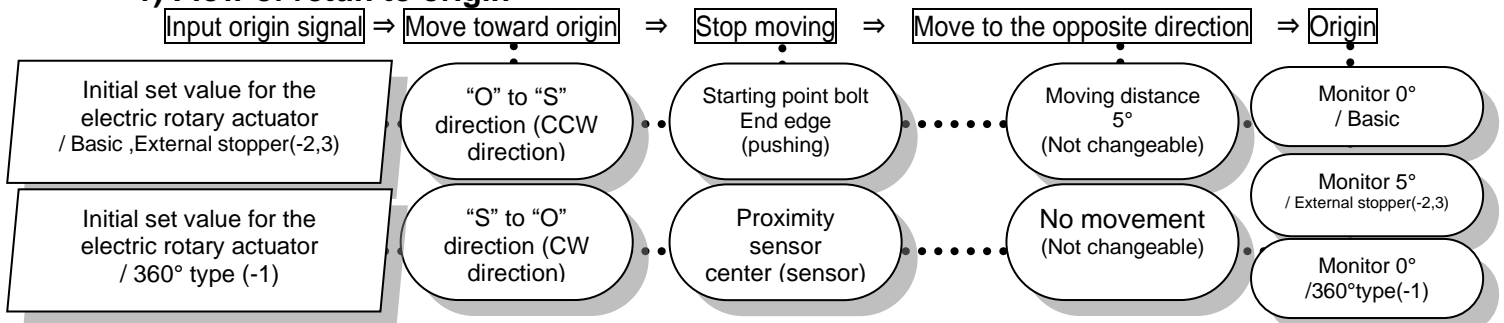

Initial setting for the ORIG parameters

Refer to the controller's (LEC series) operation manual for detail.

As the "ORIG parameter" is unique data of each actuator, if an actuator other than the electric rotary actuator is used, refer to the operation manual of each actuator and the controller's (LEC series) operation manual for the "ORIG parameters".

Description (Extract)	Initial input value	Input range
ORIG direction	2:CCW / Basic ,External stopper(-2,3) 1:CW /360° type (-1)	1:CW ("O" direction) 2:CCW ("S" direction) Note 1)
ORIG mode	1:Stop / Basic ,External stopper(-2,3) 3:Sensor1 /360° type (-1)	1: Pushing origin operation[Stop] Note 3) 2:Limit switch origin[Sensor] 3: Limit switch origin1[Sensor1]
ORIG limit	100	0 / 40 to 100 Note 2)
ORIG time	100	-
ORIG speed	20 / LER*K 30 / LER*J	-
ORIG ACC/DEC	500	-
Creep speed	20 / LER*K 30 / LER*J	-
ORIG sensor	0:Disable / Basic ,External stopper(-2,3) 1: Contact a /360° type (-1)	0:Disable 1: Contact a 2: Contact b
ORIG SW Dir	0	—
Undefined parameter 21	0	—

Note1) Become effective after restarting the controller.

Note2) Return to origin cannot return while operating. / See 5.1  Caution (4) on p. 34

Note3) Setting Return to origin to the position of the proximity sensor is available only for 360° type.

3.Limit switch origin1[Sensor1] recognizes the sensor detection range as the origin.

While detecting the sensor, the rotary table rotates in the reverse direction in the sensor detection range.

4. Wiring of cables / Common precautions

Warning

1. **Adjusting, mounting or wiring change should never be done before shutting off the power supply to the product.**

Electrical shock, malfunction and damaged can result.

2. **Never disassemble the cable. Use only specified cables.**
3. **Never connect or disconnect the cable or connector with power on.**

Caution

1. **Wire the connector securely. Do not apply any voltage to the terminals other than those specified in the product manual.**
2. **Wire the connector securely.**
Check for correct connector wiring and polarity.
3. **Take appropriate measures against noise.**
Noise in a signal line may cause malfunction. As a countermeasure, separate high voltage and low voltage cables, and shorten wiring lengths, etc.
4. **Do not route wires and cables together with power or high voltage cables.**
The product can malfunction due to interference of noise and surge voltage from power and high voltage cables to the signal line. Route the wires of the product separately from power or high voltage cables.
5. **Take care that actuator movement does not catch cables.**
6. **Operate with cables secured. Avoid bending cables at sharp angles where they enter the product.**
7. **Avoid twisting, folding, rotating or applying an external force to the cable.**
Risk of electric shock, wire break, contact failure and loss of control for the product can happen.
8. **Fix the cable protruding from the product in place before using.**
The motor and lock cables are not robotic type cables and can be damaged when moved. Therefore fix the cables and the connectors (part "A" in figure below) when set up

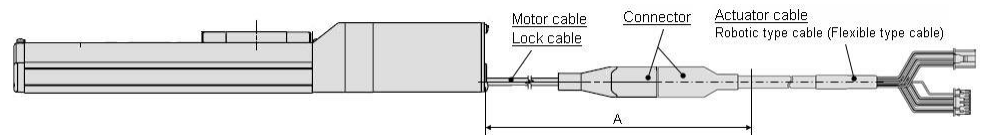

9. **Select "Robotic type cables" in case of inflecting actuator-cable repeatedly. And do not put cables into a flexible moving tube with a radius smaller than the specified value. (Min. 50mm).**
Risk of electric shock, wire break, contact failure and loss of control for the product can happen if "Standard cables" are used in case of inflecting the cables repeatedly

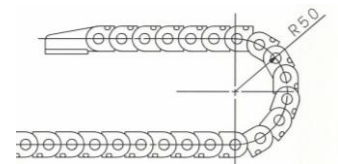

10. **Confirm proper wiring of the product.**
Poor insulation (interference with other circuits, poor insulation between terminals and etc.) can apply excessive voltage or current to the product causing damage.
11. **The Speed / pushing force may vary, depending on the cable length, load and mounting conditions etc..**
If the cable length exceeds 5m, the speed / pushing force will be reduced by a maximum of 10% per 5m. (If cable length is 15m: Maximum 20% reduction.)

[Transportation]

Caution

1. **Do not carry or swing the product by the motor or cable**

5. Electric actuators / Common precautions

5.1 Design and selection

Warning

- 1. Be sure to read the Operation Manual (this manual and the one for the controller: LEC series).**
Handling or usage/operation other than that specified in the Operation Manual may lead to breakage and operation failure of the product.
Any damage attributed to the use beyond the specifications is not guaranteed.
- 2. There is a possibility of dangerous sudden action by the product if sliding parts of machinery are twisted due to external forces etc.**
In such cases, human injury may occur, such as by catching hands or feet in the machinery, or damage to the machinery itself may occur. Design the machinery should be designed to avoid such dangers.
- 3. A protective cover is recommended to minimize the risk of personal injury.**
If a driven object and moving parts of the product are in close proximity, personal injury may occur. Design the system to avoid contact with the human body.
- 4. Securely tighten all stationary parts and connected parts so that they will not become loose.**
When the product operates with high frequency or is installed where there is a lot of vibration, ensure that all parts remain secure.
- 5. Consider a possible loss of power source.**
Take measures to prevent injury and equipment damage even in the case of a power source failure.
- 6. Consider behavior of emergency stop of whole system.**
Design the system so that human injury and/or damage to machinery and equipment will not be caused, when it is stopped by a safety device for abnormal conditions such as a power outage or a manual emergency stop of whole system.
- 7. Consider the action when operation is restarted after an emergency stop or abnormal stop of whole system.**
Design the system so that human injury or equipment damage will not occur upon restart of operation of whole system.
- 8. Never disassemble or modify (including additional machining) the product.**
An injury or failure can result.
It will cause the loss of the product performance.
- 9. Do not use the stop signal, "EMG" of the controller and stop switch on the teaching box as the emergency stop of system.**
The stop signal, "EMG" of controller and the stop switch on the teaching box are for decelerating and stopping the actuator.
Design the system with an emergency stop circuit which is applied relevant safety standard separately.
- 10. When using it for vertical application, it is necessary to build in a safety device.**
The rod may fall due to the weight of work. The safety device should not interfere with normal operation of the machine.

Caution

- 1. Operate within the limits of the maximum usable stroke.**
The product will be damaged if it is used with the stroke which is over the maximum stroke. Refer to the specifications of the product.
- 2. When the product repeatedly cycles with partial strokes, operate it at a full stroke at least once a day or every 1000 strokes.**
Otherwise, lubrication can run out.
- 3. Do not use the product in applications where excessive external force or impact force is applied to it.**
The product can be damaged. Each component that includes motor is made with accurate tolerance. So even slightly deformed or miss-alignment of component may lead operation failure of the product.

4. **Rerutning to origin cannot be done during the operation.**
It cannot be done during positioning operation, pushing operation and pushing.
5. **Refer to a common auto switch /matter (Best Pneumatics No 2) when an auto switch is built in and used.**
6. **When conformity to UL is required, the electric actuator and controller should be used with a UL1310 Class 2 power supply.**

5.2 Mounting

Warning

1. **Install and operate the product only after reading the Operation Manual carefully and understanding its contents. Keep the manual in a safe place future reference.**
2. **Observe the tightening torque for screws.**
Tighten the screws to the recommended torque for mounting the product.
3. **Do not make any alterations to this product.**
Alterations made to this product may lead to a loss of durability and damage to the product, which can lead to human injury and damage to other equipment and machinery.
4. **When using external guide, the guide axis should be parallel to the actuator axis.**
There will be damage/excessive wear on the lead screw if the external guide is not parallel.
5. **When an external guide is used, connect the moving parts of the product and the load in such a way that there is no interference at any point within the stroke.**
Do not scratch or dent the sliding parts of the product tube or piston rod etc., by striking or grasping them with other objects. Components are manufactured to precise tolerances, so that even a slight deformation may cause faulty operation.
6. **Prevent the seizure of rotating parts.**
Prevent the seizure of rotating parts (pins, etc.) by applying grease.
7. **Do not use the product until you verify that the equipment can operate properly.**
After mounting or repair, connect the power supply to the product and perform appropriate functional inspections to check it is mounted properly.
8. **At the overhang mounted impeller fixation**
There is a possibility that the power at the bending moment damages the actuator when moving it at high speed.
The support metal fittings that suppress the vibration of the main body of the actuator are installed.
Lower and use speed for the state that the actuator doesn't vibrate.
9. **When attaching the product body or work piece, do not apply strong impact or large moment.**
If an external force over the allowable moment is applied, it may cause looseness in the guide unit, an increase in sliding resistance or other problems.
10. **Maintenance space**
Allow sufficient space for maintenance and inspection.

5.3 Handling

Warning

1. Do not touch the motor while in operation.

The surface temperature of the motor can increase to approx. 80°C due to operating conditions. Energizing alone may also cause this temperature increase. As it may cause burns, do not touch the motor when in operation.

2. If abnormal heating, smoking or fire, etc., occurs in the product, immediately shut off the power supply.

3. Immediately stop operation if abnormal operation noise or vibration occurs.

If abnormal operation noise or vibration occurs, the product may have been mounted incorrectly. Unless operation of the product is stopped for inspection, the product can be seriously damaged.

4. Never touch the rotating part of the motor or moving part of the actuator while in operation.

5. When installing, adjusting, inspecting or performing maintenance on the product, controller and related equipment, be sure to shut off the power supply to them. Then, lock it so that no one other than the person working can turn the power on, or implement measures such as a safety plug.

6. In the case of the actuator that has a servo motor (24VDC), the “motor phase detection step” is done by inputting the servo on signal just after the controller power is turned on.

The “motor phase detection step” moves the table/rod for the distance of the one screw-lead as the maximum. (The motor rotates in the reverse direction if the table hits an obstacle such as the end stop damper.) Take the “motor phase detection step” into consideration for the installation and operation of this actuator.

Caution

1. Keep the controller and product combined as delivered for use.

The product is set in parameters for shipment. If it is combined with a different parameter, failure can result.

2. Check the product for the following points before operation.

- a) Damage to electric driving line and signal line.
- b) Looseness of the connector to each power line and signal line.
- c) Looseness of the actuator /cylinder and controller /driver mounting
- d) Abnormal operation
- e) Emergency stop of the total system

3. When more than one person is performing work, decide on the procedures, signals, measures and resolution for abnormal conditions before beginning the work. Also, designate a person to supervise work other than those performing work.

4. Actual speed of the product will be changed by the workload.

Before selecting a product, check the catalog for the instructions regarding selection and specifications.

5. Do not apply a load, impact or resistance in addition to a transferred load during return to origin.

In the case of the return to origin by pushing force, additional force will cause displacement of the origin position since it is based on detected motor torque.

6. Do not remove the nameplate.

7. Operation test should be done by low speed. Start operation by predefined speed after confirming there is no trouble.

[Earth]

Warning

1. Please give the earth to the actuator.

2. Please make it to the earth of exclusive use. The earth construction is D seed.
(Below earth resistance 100Ω)

3. Please shorten the distance until the actuator and earth.

[Unpackaging]

Caution

1. Check the received product is as ordered.

If the different product is installed from the one ordered, injury or damage can result.

5.4 Operating environment

Warning

1. Avoid use in the following environments.

- a. Locations where a large amount of dusts and cutting chips are airborne.
- b. Locations where the ambient temperature is outside the range of the temperature specification (refer to specifications).
- c. Locations where the ambient humidity is outside the range of the humidity specification (refer to specifications).
- d. Locations where corrosive gas, flammable gas, sea water, water and steam are present.
- e. Locations where strong magnetic or electric fields are generated.
- f. Locations where direct vibration or impact is applied to the product.
- g. Areas that are dusty, or are exposed to splashes of water and oil drops.
- h. Areas exposed to direct sunlight (ultraviolet ray).

2. Do not use in an environment where the product is directly exposed to liquid, such as cutting oils.

If cutting oils, coolant or oil mist contaminates the product, failure or increased sliding resistance can result.

3. Install a protective cover when the product is used in an environment directly exposed to foreign matters such as dust, cutting chips and spatter.

Play or increased sliding resistance can result.

4. Shade the sunlight in the place where the product is applied with direct sunshine.

5. Shield the valve from radiated heat generated by nearby heat sources.

When there is a heat source surrounding the product, the radiated heat from the heat source can increase the temperature of the product beyond the operating temperature range. Protect it with a cover, etc.

6. Grease oil can be decreased due to external environment and operating conditions, and it deteriorates lubrication performance to shorten the life of the product.

[Storage]

Warning

1. Do not store the product in a place in direct contact with rain or water drops or is exposed to harmful gas or liquid.

2. Store in an area that is shaded from direct sunlight and has a temperature and humidity within the specified range (-10°C to 60°C and 90%RH or less No condensation or freezing).

3. Do not apply vibration and impact to the product during storage.

5.5 Maintenance

Warning

- 1. Do not disassemble or repair the product.**
Fire or electric shock can result.
Contact SMC, in case of disassembly for the maintenance.
- 2. Before modifying or checking the wiring, the voltage should be checked with a tester 5 minutes after the power supply is turned off.**
Electrical shock can result.

Caution

- 1. Maintenance should be performed according to the procedure indicated in the Operating Manual.**
Incorrect handling can cause an injury, damage or malfunction of equipment and machinery.
- 2. Removal of product**
When equipment is serviced, first confirm that measures are in place to prevent dropping of work pieces and run-away of equipment, etc, and then cut the power supply to the system. When machinery is restarted, check that operation is normal with actuators in the proper positions.

[Lubrication]

Caution

- 1. The product has been lubricated for life at manufacturer, and does not require lubrication in service.**
When lubrication is applied, special grease must be used.

5.6 Precautions for actuator with lock

Warning

- 1. Do not use the lock as a safety lock or a control that requires a locking force.**
The lock used for the product with a lock is designed to prevent dropping of work piece.
- 2. For vertical mounting, use the product with a lock.**
If the product is not equipped with a lock, the product will move and drop the work piece when the power is removed.
- 3. "Measures against drops" means preventing a work piece from dropping due to its weight when the product operation is stopped and the power supply is turned off.**
- 4. Do not apply an impact load or strong vibration while the lock is activated.**
If an external impact load or strong vibration is applied to the product, the lock will lose its holding force and damage to the sliding part of the lock or reduced lifetime can result. The same situations will happen when the lock slips due to a force higher than its holding force, as this will accelerate the wear to the lock.
- 5. Do not apply liquid or oil and grease to the lock or its surrounding.**
When liquid or oil and grease are adhered to the sliding part of the lock, its holding force will reduce significantly. Or, lock sliding part performance and condition changes may be cause of lock release malfunction.
- 6. Take measures against drops and check that safety is assured before mounting, adjustment and inspection of the product.**
If the lock is released with the product mounted vertically, a work piece can drop due to its weight.
- 7. When the actuator is operated manually (when SVRE output signal is off), supply 24DCV to the [BK RLS] terminal of the power supply connector.**
If the product is operated without releasing the lock, wearing of the lock sliding surface will be accelerated, causing reduction in the holding force and the life of the locking mechanism.
- 8. Do not supply 24VDC power supply constantly to the [BK RLS(Lock release)] terminal.**
Stop supplying 24VDC power supply to the [BK RLS(Lock release) terminal during normal operation. If power is supplied to the [BK RLS] terminal continuously, the lock will be released, and workpieces may be dropped at stop (EMG).
/Refer to the operation manual of LEC (controller) for details of wiring.

6. Electric Rotary Table /Specific Product Precautions

6.1 Design and selection

Warning

- If the operating conditions involve load fluctuations, ascending/descending movements, or changes in the frictional resistance, ensure that safety measures are in place to prevent injury to the operator or damage to the equipment**
Failure to provide such measures could accelerate the operating speed, which may be hazardous to humans, machinery, and other equipment.
- Power failure may result in a decrease in the pushing force; ensure that safety measures are in place to prevent injury to the operator or damage to the equipment.**
When the product is used for clamping, the clamping force could be decreased due to power failure, potentially creating a hazardous situation in which the work piece is released.

Caution

- If the operating speed is set too fast and the moment of inertia is too large, the product could be damaged.**
Set appropriate product operating conditions in accordance with the model selection procedure.
- If more precise repeatability of the rotation angle is required, use the product with an external stopper, with repeatability of $\pm 0.01^\circ$ (180° and 90° with adj. of $\pm 2^\circ$) or by directly stop the workpiece using an external object utilizing the pushing operation.**

6.2 Mounting

Caution

- Do not drop or hit the rotary actuator to avoid scratching and denting the mounting surfaces.**
Even slight deformation can cause the deterioration of accuracy and operation failure.
- When mounting the rotary actuator use screws with adequate length and tighten them with adequate torque within the specified torque range.**
Tightening the screws with a higher torque than recommended may cause malfunction, whilst the tightening with a lower torque can cause the displacement of the mounting position or in extreme conditions the actuator could become detached from its mounting position.

Mounting the workpiece to the rotary table

Mount the workpiece to the table using the screw length and tightening torque specified in the table below. Using long screws which interfere with the body may cause operation failure.

Part no.	Bolt	Screw length [mm]	Max. tightening torque [Nm]
LER*10	M4x0.7	6	1.4
LER*30	M5x0.8	8	3.0
LER*50	M6x1	10	5.0

Rotary actuator mounting (thro holes)

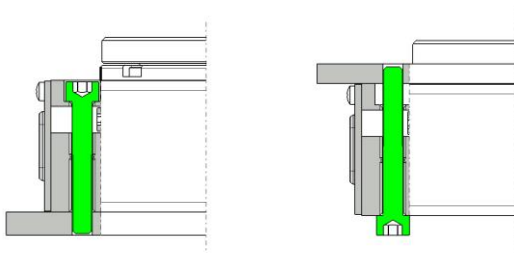

Part no.	Bolt	Max. tightening torque [Nm]
LER*10	M5x0.8	3.0
LER*30	M6x1	5.0
LER*50	M8x1.25	12.0

Rotary actuator mounting (tapped holes)

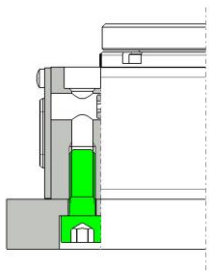

Part no.	Bolt	Max. tightening torque [Nm]	Max. thread depth L[mm]
LER*10	M6×1	5.0	12
LER*30	M8×1.25	12.0	16
LER*50	M10×1.5	25.0	20

- The mounting face has holes and slots for positioning. If required use them for accurate positioning of the rotary actuator.
- If it is necessary to operate the product when it is not energized, use the manual override screws.

When the product is operated with the manual override screws, check the position of the manual override of the table, and leave necessary space. Do not apply excessive torque to the manual override screws that could lead to damage and malfunction of the product.

- The proximity sensor for the return to origin for 360° type can be rotated +/-30°. If the position of the proximity sensor for return to origin is changed, the tightening torque must be 0.6 +/-0.1 [Nm]

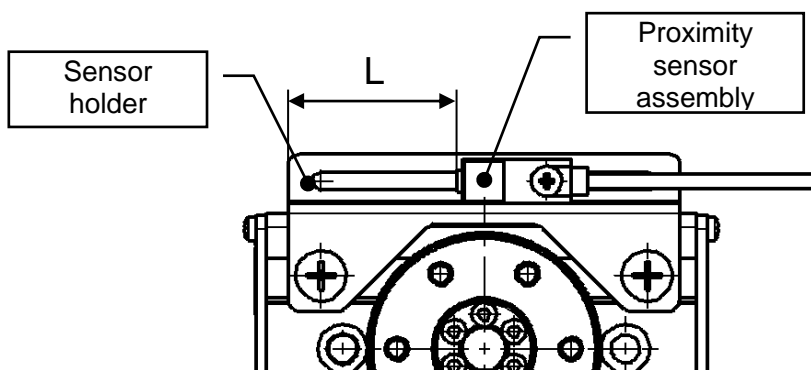

Part no.	L[mm] (Default value) Cable entry: Basic type / Entry from the left (Between the sensor holder end and Proximity sensor end)
LER*10-1	31 / 31
LER*30-1	42 / 42
LER*50-1	51.5 / 51.5

6.3 Handling

⚠ Caution

- If an external guide is mounted, connect it so that impact and load will not be applied to it. Use a freely moving connector (such as a coupling).
- The positioning force should be set to 100% of the the initial value. If the positioning force is set below the initial value, there may be variation in the cycle time, or an alarm may be generated.
- INP output signal

1) Positioning operation

When the product comes within the set range by step data [In position], output signal will be turned on. Initial value: Set to [0.50] or higher.

2) Pushing operation

When the pushing force exceeds the [TriggerLV] value the INP (In position) output signal is turned on. Please set the [Pushing force] and the [TriggerLV] within the specified range.

- To ensure that the actuator pushes the workpiece by the inputted [pushing force], it is recommended that the [TriggerLV] is set to the same value as the [pushing force].
- When the [TriggerLV] and [pushing force] are set to be less than the lower limit of the specified range, there is the possibility that the INP output signal will be switched on from the pushing operation start position.

< Pushing force and trigger LV range >

Model	Set value of pushing force[%]	Set value of TriggerLV[%]
LER*	40~50	40~50

4. **When the load is to be stopped by the product with an external stopper or an external object directly, utilize the “pushing operation”. Do not stop the table with an external object by positioning operation and in the range of the positioning operation.**
If the product is used in the positioning operation, there may be galling or other problems when it comes into contact with the external object.
5. **When the table is stopped by pushing operation (stopping or clamping), set the product to a position of at least 1 ° away from a work piece (This position is referred to as a pushing start position).**
If the pushing operation (stopping or clamping) is set to the same position as the externally stopping position, the following alarms may be generated and operation may become unstable.
 - a. **“Posn failed” alarm**
The product cannot reach a pushing start position due to the deviation of work pieces in width.
 - b. **“Pushing ALM” alarm**
The product is pushed back from a pushing start position after starting to push.
 - c. **“Err overflow” alarm**
The displacement at the pushing start position exceeds the specified range.
6. **If the table is stopped by an external object, there is no backlash effect in pushing operation.**
The return to origin position is set by pushing operation.
7. **In the external stopper specification, an angle adjustment screw (adjuster bolt) is mounted as the standard specification.**
The rotation angle adjustment range is +/-2° from the angle rotation end.
If the adjustment range is exceeded, the rotation angle may change due to insufficient strength of the external stopper.
The angle adjustment of the adjuster bolt is 1 ° /rotation (reference).
8. **In case that gravity is added to the work-piece along the rotation direction when product is mounted vertically, the work-piece may fall down when "SVON" signal is OFF or EMG is not energizing.**
9. **When mounting the product, keep a 40 mm or longer diameter for bends in the motor cable.**
10. **Grounding method of the actuator.**
 1. The cross-sectional area of this wire shall be a minimum of 2 mm².
 2. Avoid common grounding with other devices.

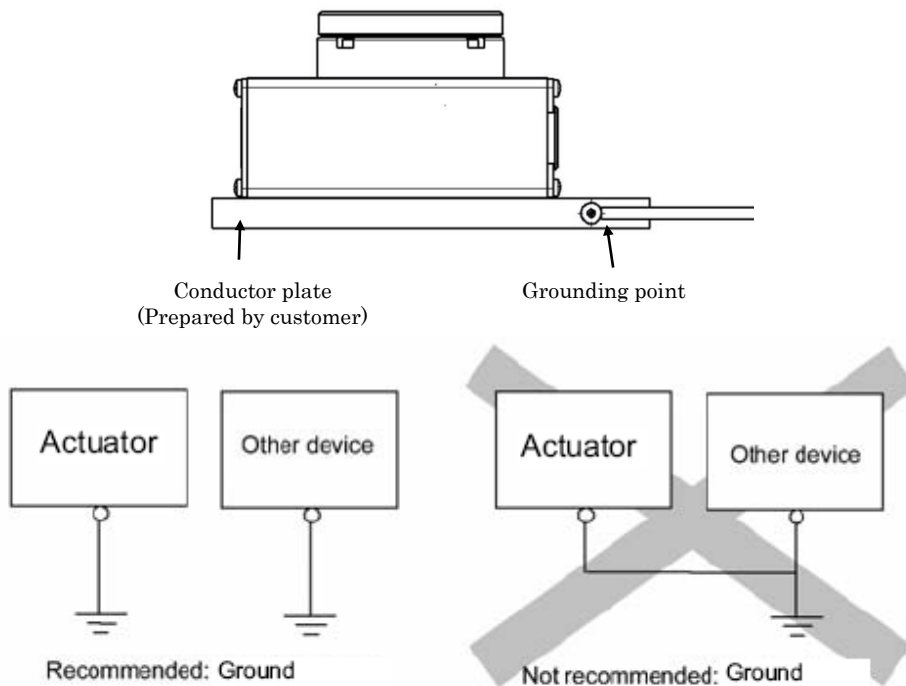

6.4 Maintenance



Warning

1. **The high precision bearing is assembled by pushing into position. It is not possible to disassemble it.**

7. Troubleshooting

Alarms below are abstract of representative examples.

For other alarms, see operation manual of controller.

No.	Phenomenon	Cause	Countermeasure	
1	The display unit is distance (mm) due to the controller setting software.	When the controller setting software/version is below 1.1, the display unit is distance (mm), but the product recognizes it as an angle(°)	If it is necessary to change it to the angle display, please upgrade the controller setting software. To upgrade the software, please go to the operation manual page of SMC website. http://www.smcworld.com/	
2	Fail to operate / Initial stage When power is supplied, alarm for "Phase Det ALM /code: 1-193" is generated. ↓ <Procedure of restart> "Turn the power supply off." ↓ "Turn the power supply on"	1) The cable is not connected or has been disconnected.	Confirm that the cable is connected correctly. /See 4. Wiring of cable on p. 33	
		2) The load/resistance being applied to the actuator constantly exceeds the actuators specification.	Keep the load/resistance within the specified range. /See Specifications on p.10 ,p14	
		3) The combination of the controller and the rotary actuator is not correct.	The controller and rotary actuator combination at the time of shipment should not be changed. /See 5.3⚠Caution(1) on p.36	
		4) Excessive external force is being applied, (including vibration) or impact load.	Operate within the specified range. /See 2.1 Specifications on p.9 Release the warm using the manual override. /See 6.2⚠Caution(5) on p.40	
		Alarm for "Step data ALM1 /code:1-048" is generated ↓ <Procedure of restart> Input the "reset signal."	Setting condition for step data is not correct. < Correct set condition > (1)Area 1 < Area 2 (2) Trigger LV ≤ Pushing force (3) Pushing speed ≤ Speed (4) Pushing force ≥ Min. pushing force (40 %)	Review the content of step data. / Refer to the LEC controller operation manual.
		Alarm for "Servo off ALM /code: 1-098" is generated ↓ <Procedure of restart> Input the "reset signal."	Perform positioning, pushing operation, return to origin and jog operation during the "SVON":OFF.	Provide the operation instruction after confirming that the input signal [SVON] is ON and then the output signal [SVRE] is ON.
		Alarm for "Drive ALM /code: 1-099" is generated. ↓ <Procedure of restart> Input the "reset signal."	Perform positioning, pushing operation before the"retun to origin".	Provide the operation instruction after confirming that the input signal [SETUP] is ON and then the output signal [SETON] is ON.
	"ORIG direction" cannot be change.	After the "ORIG direction" is changed, the controller power supply has not been turned OFF.	Become effective after restarting the controller. /See "Initial setting for the ORIG parameters" on p.32	

No.	Phenomenon	Cause	Countermeasure
3	Operation not completed / Operation continue Alarm for "Posn failed /code: 1-149" is generated. ↓ <Procedure of restart> Input the "reset signal." →"SVRE": Automatically ON	1) The lead screw had galling due to excessive external force (including vibration) or impact.	Operate within the specified range /See Specifications on p10,p14 Release the warm using the manual override. /See 6.2⚠Caution (5) on p.40
		2) The Power supply does not have sufficient capacity.	Check the power consumption for each actuator and controller: If necessary replace the existing power supply with a power supply with sufficient capacity. /See Specifications on p10,p14
		3) Load/resistance more than specified range is being applied to the actuator.	Use within specification range. /See Specifications on p10,p14
		4) The pushing operation is performed at the "Positioning operation" position.	Check the step data. "-2-3", Or if you have to stop the load directly in the external, set to pushing operation, please use. /See 6.3⚠Caution (5) on p.41
		5) For the pushing operation: The position and the target start pushing position are not set correctly.	Check the step data. /See 6.3⚠Caution (5) on p.41
		6) The cable is not connected or has been disconnected.	Confirm that the cable is connected correctly. /See 4. Wiring of cable on p.33
		7) It was not the intended origin position because the rotary actuator pinched the work-piece during the"return to origin".	Remove the work-piece and restart the return to the intended origin position.
		8) Wrong input [0] is input as the positioning force.	Check the step data. <Moving force> /See "Step data setting" on p.22,24
		9) The step data position has not been changed correctly after the return to origin direction is changed.	Check the step data. <Position> /See "Step data setting" on p.22,24
		10) Because the operation of the step data is set to [INC/relative], the table comes into contact with an external object and does not move due to continuous operation. (Rotathion end etc.)	Check the step data. <Position> /See "Step data setting" on p.22,24 Check if correct operation instruction is provided.

No.	Phenomenon	Cause	Countermeasure
3	Alarm for "Pushing ALM /code: 1-096" is generated. ↓ <Procedure of restart> Input the "reset signal." →"SVRE": Automatically ON	1) For the pushing operation, the position, target start-pushing position, is not set correctly.	Check the step data. /See 6.3 ⚠ Caution (5) on p.41
		2) It was not intended origin position because rotary actuator pinched work-piece during returning return to origin.	Remove the work-piece and command again the returning to origin that is intended.
	Operation is not completed / Operation continue Alarm for "Over motor Vol /code: 1-145" is generated. ↓ <Procedure of restart> Input the "reset signal." →"SVRE": Automatically ON	1) If the power supply is an "inrush-current restraining type", the alarm may be generated due to voltage drop.	Replace the power supply with a non "inrush-current restraining type" power supply. / Refer to the LEC controller operation manual.
		2) The Power supply does not have sufficient capacity.	Check the power consumption for each actuator and controller: If necessary replace the existing power supply with a power supply with sufficient capacity. /See Specifications on p10,p14
	Alarm for " Err overflow /code: 1-196" is generated. ↓ <Procedure of restart> "Turn the power supply off." ↓ "Turn the power supply on"	1) The lead screw had galling due to excessive external force (including vibration) or impact.	Operate within the specified range /See 2.1 Specifications on p.9 Release the warm using the manual override. /See 6.2 ⚠ Caution (5) on p.40
		2) The Power supply does not have sufficient capacity.	Check the power consumption for each actuator and controller: If necessary replace the existing power supply with a power supply with sufficient capacity. /See Specifications on p10,p14
		3) Load/resistance more than specified range is being applied to the actuator.	Use within specification range. /See Specifications on p10,p14
		4) The pushing operation is performed at the "Positioning operation" position.	Check the step data."-2-3", Or if you have to stop the load directly in the external, set to pushing operation, please use. /See 6.3 ⚠ Caution (5) on p.41
		5) For the pushing operation: The position and the target start pushing position are not set correctly.	Check the step data. /See 6.3 ⚠ Caution (5) on p.41
		6) The cable is not connected or has been disconnected.	Confirm that the cable is connected correctly. /See 4. Wiring of cable on p.33
7) It was not the intended origin position because the rotary actuator pinched the work-piece during the"return to origin".		Remove the work-piece and restart the return to the intended origin position.	

No.	Phenomenon	Cause	Countermeasure
3	Alarm for "Err overflow /code: 1-196" is generated. ↓ <Procedure of restart> "Turn the power supply off." ↓ "Turn the power supply on"	8) Wrong input [0] is input as the positioning force.	Check the step data. <Moving force> /See "Step data setting" on p.22,24
		9) The step data position has not been changed correctly after the return to origin direction is changed.	Check the step data. <Position> /See "Step data setting" on p.22,24
		10) Because the operation of the step data is set to [INC/relative], the table comes into contact with an external object and does not move due to continuous operation. (Rotathion end etc.)	Check the step data. <Position> /See "Step data setting" on p.22,24 Check if correct operation instruction is provided.
	Operation not completed / During operation (Not always, but may happen occasionally) Alarm for "Step data ALM2 /code: 1-051" is generated. ↓ <Procedure of restart> Input the "reset" signal.	1) Command invalid (unregistered) step data.	Check if the step data is valid (registered).
		2) Different input signal to the expected step number is inputted to the controller, because of a too short an interval between the input signal of the "IN*" and the "Drive" or inputting the signals at the same time.	Add an interval of 15ms (the recommendation is 30ms) or more between the input signals. / See "Operating procedure input and output signals for each operation type" on P.29
		3) Different input signal to the expected step number is inputted to the controller, because the input signal time was too short.	Add an interval of 15ms (the recommendation is 30ms) or more between the input signals. / See "Operating procedure input and output signals for each operation type" on P.29
		4) Different input signal to the expected step number is inputted to the controller, caused by PLC or other device.	Check that the step number is inputted correctly for the required motion.
	- Operation completed by unexpected motion. - No alarm / During operation (Not always, but may happen occasionally)	1) Different input signal to the expected step number is inputted to the controller, because of a too short an interval between the input signal of the "IN*" and the "Drive" or inputting the signals at the same time.	Add an interval of 15ms (the recommendation is 30ms) or more between the input signals. / See "Operating procedure input and output signals for each operation type" on P.29 Note) Recommend to check the "OUT" output signal for more secure operation.
		2) Different input signal to the expected step number is inputted to the controller, because the input signal time was too short.	Add an interval of 15ms (the recommendation is 30ms) or more between the input signals. / See "Operating procedure input and output signals for each operation type" on P.29 Note) Recommend to check the "OUT" output signal for more secure operation.
		3) Different input signal to the expected step number is inputted to the controller, caused by PLC or other device.	Check that the step number is inputted correctly for the required motion. / See "Operating procedure input and output signals for each operation type" on P.29 Note) Recommend to check the "OUT" output signal for more secure operation.

No.	Phenomenon	Cause	Countermeasure
4	“INP” output signal is unstable. Positioning completion signal [INP] is not outputted.	1) The value of [In position] in step data is too small.	Check the step data. <In Pos> (Minimum value:0.5) /See “Step data setting” on p.22
	“INP” output signal is [OFF]. “INP” output signal is [OFF] even after the pushing operation is completed.	1)The value of "In pos" is input forward of work.	Input the value of "In pos" larger than length to work. /See “Example of step data entry (3)” on p.27
5	Positioning repeatability is out of specified range.	1) It shifts to the next operation by receiving the "INP" output signal.	Go to the next operation after receiving the “BUSY” output signal is outputted.
6	The operation time is delayed to the step date setting.	1) The inertia moment-angle acceleration and deceleration and effective torque - angular speed exceed the specified range.	Check this with the model selection stated in the catalog.
7	Damage	1) Abnormal external force	Interference of mechanism, eccentric load or excess load leads to cause deformation or damage of the actuator. Eliminate these factors.
8	The rod of the actuator with vertical mounting vibrates repeated up and down.	1) The inertia moment-angle acceleration and deceleration and effective torque - angular speed exceed the specified range.	Check this with the model selection stated in the catalog.

Revision history

No.LER-OM00201

Feb / 2011 1st printing

No.LER-OM00202

Mar / 2011 Revision

No.LER-OM00203

Apr / 2012 Revision

- Addition / Notes about UL recognition

No.LER-OM00204

Feb / 2013 Revision

- Addition / LER*-1 Series. (360°Type)

No.LER-OM00205

Apr / 2013 Revision

No.LER-OM00206

Nov / 2013 Revision

- How to Order
- Change of specification

No.LER-OM00207

Jan / 2014 Revision

- Part material change(Proximity dog)

No.LER-OM00208

Jan / 2015 Revision

- Change of specification

No.LER-OM00209

May / 2015 Revision

- Change of Initial setting for the basic parameters

No.LER-OM00210

Sep / 2015 Revision

- Change of specification and specific product precautions

No.LER-OM00211

Mar / 2016 Revision

- Change of common precautions

No.LER0-OM00303

May / 2019 Revision

- Change of specific product precautions

No.LER0-OM00303

February / 2025 Revision

- Change of safety Instructions

SMC Corporation

Tel: + 81 3 5207 8249 Fax: +81 3 5298 5362

URL <http://www.smcworld.com>

Note: Specifications are subject to change without prior notice and any obligation on the part of the manufacturer.

© 2016 SMC Corporation All Rights Reserved