



# Operation Manual

PRODUCT NAME

*Ionizer*

MODEL / Series / Product Number

IZF21/31 Series

**SMC Corporation**

# Contents

<b>Safety Instructions</b> .....	<b>3</b>
<b>1. How to Order</b> .....	<b>8</b>
1-1. Ionizer .....	8
1-2. Accessories .....	8
1-3. Option .....	10
<b>2. Procedures to Operation</b> .....	<b>10</b>
<b>3. Installation and Wiring</b> .....	<b>11</b>
3-1. Installation .....	11
3-1-1. Precautions for Installation .....	11
3-1-2. Installation of Ionizer .....	12
3-2. Wiring .....	13
3-2-1. Connection Circuit .....	13
3-2-2. Wiring of the Power Supply Cable .....	15
3-2-3. Wiring of the AC Adapter .....	15
3-3. Timingchart .....	16
<b>4. Function</b> .....	<b>17</b>
4-1. Name of Parts .....	17
4-2. Adjustment of Offset Voltage .....	17
4-3. Adjustment of Air Flow .....	18
4-4. Emitter Dirt Detection and Cleaning .....	19
4-4-1. Manual Cleaning .....	19
4-4-2. Emitter Cleaning with an Automatic Cleaning Unit (Option) .....	20
4-4-3. Automatic Cleaning Unit Assembly .....	21
4-4-4. Replacement of Cleaning Arm .....	22
4-5. Replacement of Emitter Cartridge .....	23
4-6. Alarm Function .....	23
4-7. Offset Voltage Performance Maintaining Function .....	25
4-7-1. Ion Balance Sensor .....	25
4-7-2. Averaging Function .....	25
4-8. Louver (Option) .....	26
4-9. Filter (Option) .....	27
<b>5. Performance</b> .....	<b>28</b>
5-1. Basic Performance .....	28
<b>6. Dimensions</b> .....	<b>30</b>
<b>7. Specifications</b> .....	<b>34</b>
<b>8. Troubleshooting</b> .....	<b>35</b>



# Safety Instructions

These safety instructions are intended to prevent hazardous situations and/or equipment damage. These instructions indicate the level of potential hazard with the labels of “**Caution**,” “**Warning**” or “**Danger**.” They are all important notes for safety and must be followed in addition to International Standards (ISO/IEC)<sup>\*)</sup>, and other safety regulations.

\*) ISO 4414: Pneumatic fluid power - General rules and safety requirements for systems and their components  
 ISO 4413: Hydraulic fluid power - General rules and safety requirements for systems and their components  
 IEC 60204-1: Safety of machinery - Electrical equipment of machines - Part 1: General requirements  
 ISO 10218-1: Robots and robotic devices - Safety requirements for industrial robots - Part 1: Robots  
 etc.

	<b>Danger</b>	<b>Danger</b> indicates a hazard with a high level of risk which, if not avoided, will result in death or serious injury.
	<b>Warning</b>	<b>Warning</b> indicates a hazard with a medium level of risk which, if not avoided, could result in death or serious injury.
	<b>Caution</b>	<b>Caution</b> indicates a hazard with a low level of risk which, if not avoided, could result in minor or moderate injury.

## Warning

### 1. The compatibility of the product is the responsibility of the person who designs the equipment or decides its specifications.

Since the product specified here is used under various operating conditions, its compatibility with specific equipment must be decided by the person who designs the equipment or decides its specifications based on necessary analysis and test results. The expected performance and safety assurance of the equipment will be the responsibility of the person who has determined its compatibility with the product. This person should also continuously review all specifications of the product referring to its latest catalog information, with a view to giving due consideration to any possibility of equipment failure when configuring the equipment.

### 2. Only personnel with appropriate training should operate machinery and equipment.

The product specified here may become unsafe if handled incorrectly. The assembly, operation and maintenance of machines or equipment including our products must be performed by an operator who is appropriately trained and experienced.

### 3. Do not service or attempt to remove product and machinery/equipment until safety is confirmed.

1. The inspection and maintenance of machinery/equipment should only be performed after measures to prevent falling or runaway of the driven objects have been confirmed.
2. When the product is to be removed, confirm that the safety measures as mentioned above are implemented and the power from any appropriate source is cut, and read and understand the specific product precautions of all relevant products carefully.
3. Before machinery/equipment is restarted, take measures to prevent unexpected operation and malfunction.

### 4. Our products cannot be used beyond their specifications. Our products are not developed, designed, and manufactured to be used under the following conditions or environments. Use under such conditions or environments is not covered.

1. Conditions and environments outside of the given specifications, or use outdoors or in a place exposed to direct sunlight.
2. Use for nuclear power, railways, aviation, space equipment, ships, vehicles, military application, equipment affecting human life, body, and property, fuel equipment, entertainment equipment, emergency shut-off circuits, press clutches, brake circuits, safety equipment, etc., and use for applications that do not conform to standard specifications such as catalogs and operation manuals.
3. Use for interlock circuits, except for use with double interlock such as installing a mechanical protection function in case of failure. Please periodically inspect the product to confirm that the product is operating properly.



# Safety Instructions

## Caution

We develop, design, and manufacture our products to be used for automatic control equipment, and provide them for peaceful use in manufacturing industries.

**Use in non-manufacturing industries is not covered.**

Products we manufacture and sell cannot be used for the purpose of transactions or certification specified in the Measurement Act.

The new Measurement Act prohibits use of any unit other than SI units in Japan.

## Limited warranty and Disclaimer/Compliance Requirements

The product used is subject to the following “Limited warranty and Disclaimer” and “Compliance Requirements”. Read and accept them before using the product.

### Limited warranty and Disclaimer

1. The warranty period of the product is 1 year in service or 1.5 years after the product is delivered, whichever is first.\*2)  
Also, the product may have specified durability, running distance or replacement parts. Please consult your nearest sales branch.
2. For any failure or damage reported within the warranty period which is clearly our responsibility, a replacement product or necessary parts will be provided.  
This limited warranty applies only to our product independently, and not to any other damage incurred due to the failure of the product.
3. Prior to using SMC products, please read and understand the warranty terms and disclaimers noted in the specified catalog for the particular products.

**\*2) Vacuum pads are excluded from this 1 year warranty.**

A vacuum pad is a consumable part, so it is warranted for a year after it is delivered.

Also, even within the warranty period, the wear of a product due to the use of the vacuum pad or failure due to the deterioration of rubber material are not covered by the limited warranty

### Compliance Requirements

1. The use of SMC products with production equipment for the manufacture of weapons of mass destruction (WMD) or any other weapon is strictly prohibited.
2. The exports of SMC products or technology from one country to another are governed by the relevant security laws and regulations of the countries involved in the transaction. Prior to the shipment of a SMC product to another country, assure that all local rules governing that export are known and followed.

## Selection

### Warning

- 1) **These products are intended for use in general factory automation equipment.**
- 2) **Use within the specified voltage and temperature range.**  
Operation with a voltage other than that specified can cause malfunction, damage to the product, electric shock or fire.
- 3) **The product is not designed to be explosion proof.**  
Never use in an atmosphere of potential dust explosion, flammable gas or explosive gas. It may cause fire.

### Caution

- 1) **Clean specification is not available with this product.**

## Installation

### Warning

- 1) **Secure enough space for maintenance, inspection and wiring.**  
Install the product in consideration of the connector connection part and the emitter cartridge mounting part so that there is enough space for emitter maintenance, inspection and wiring.  
To avoid unreasonable stress applied to the connector mounting parts, bending of the cable should be more than the minimum bending radius. If the cable is bent in an acute angle or load is applied to the cable successively, it may cause malfunction, broken wire or fire.
- 2) **Mount the product to a flat surface.**  
Mounting on an uneven surface will apply excess force to the frame or case, which leads to damage or failure. Do not drop the product or subject it to a strong impact. This may cause an injury or accident.
- 3) **Avoid using in a place where noise (electromagnetic wave and surge) is generated.**  
If the product is used in an environment where noise is generated, it may lead to deterioration or damage of the internal elements. Take measures to prevent noise at its source and avoid power and signal lines from coming into close contact.
- 4) **Use a correct tightening torque.**  
If the screws are tightened in excessive of the specified torque range, it may damage the mounting screws, mounting brackets, etc. If the tightening torque is insufficient, the mounting screws and brackets may become loose.
- 5) **Do not adhere tape or sticker onto the product body.**  
If the tape or sticker contains conductive adhesive or reflective paint, it is possible that due to the dielectric effect, charge could build up causing an electro-static discharge or electrical leakage.
- 6) **Be sure to cut off the power supply before installing and adjusting the product.**

### Caution

- 1) **Secure enough space on the rear side of the Ionizer so that the fan absorbs the air.**  
This product ventilates with an fan motor. If there are obstacles such as wall on the rear side (Air absorption side) of the Ionizer, the ventilation will be obstructed, decreasing the static neutralization performance. Install the Ionizer so that its rear surface is at least 20 mm (For IZF21) or 30 mm (For IZF31) away from the obstacles.
- 2) **Make sure to confirm the effect of static neutralization after installation.**  
The effect of the static neutralization varies depending on the surrounding installation and operating conditions. Confirm the effect of the static neutralization after installation.
- 3) **When installing Ionizers which operate in DC mode (one polarity, positive or negative) close together, they should be positioned at least 2m away from each other.**  
When an Ionizer is used close to the Ionizer which operates in DC mode, separate them by at least 2m. The offset voltage (ion balance) may not be adjusted by the built-in sensor due to the ions discharged from the Ionizer which operates in DC mode.

**4) Do not apply an excessive external force to the finger guard on the air adsorption side.**

If an excessive external force is applied to the finger guard (including the filter holder) on the air adsorption side, it may be broken. Do not apply an external force of more than 50 N to the finger guard.

## Wiring

### **Warning**

- 1) Before wiring, ensure that the power supply capacity is larger than the specification and that the voltage is within the specification.
- 2) To maintain product performance, the power supply shall be UL listed Class 2 certified by National Electric Code (NEC) or evaluated as a limited power source provided by UL60950.
- 3) To maintain the product performance, ground the product with an earth ground cable with a resistance of 100  $\Omega$  or less according to this manual.
- 4) Remove the power supply before wiring (including the connector plug in/out).
- 5) Ensure the safety of wiring and surrounding conditions before supplying power.
- 6) Do not connect or disconnect the connectors (including power source) while the power is being supplied. The Ionizer may malfunction.
- 7) Malfunctions stemming from noise may occur if the wire is installed in the same route as that of power or high-voltage cable. Wire the Ionizer independently.
- 8) Confirm that there is no error in wiring before operation. Incorrect wiring will lead to malfunction or may damage the controller or its peripheral devices depending on the seriousness of the wiring error.

## Operating and Storage Environment

### **Warning**

**1) Keep within the specified ambient temperature range.**

The specified ambient temperature range for Ionizer is 0 to 50°C, and for AC adapter is 0 to 40°C. Avoid sudden temperature changes even within specified ambient temperature range, as it may cause condensation.

**2) Do not use this product in an enclosed space.**

This product utilizes the corona discharge phenomenon. Although the amount is very small, Ozone and NOx are generated. Do not use in an enclosed space.

**3) Environments to avoid**

Never use or store under the following conditions. These may cause an electric shock, fire, etc.

- a. Areas where ambient temperature exceeds the operating temperature range.
- b. Areas where ambient humidity exceeds the operating humidity range.
- c. Areas where abrupt temperature changes may cause condensation.
- d. Areas where corrosive gas, flammable gas or other volatile flammable substances are stored.
- e. Areas where the product may be exposed to conductive powder such as iron powder or dust, oil mist, salt, organic solvent, machining chips, particles or cutting oil (including water and any liquids), etc.
- f. Paths of direct air flow, such as air conditioners.
- g. Enclosed or poorly ventilated areas.
- h. Locations that are exposed to direct sunlight or heat radiation.
- i. Areas where strong electromagnetic noise is generated, such as strong electrical and magnetic fields or supply voltage spikes.
- j. Areas where the product is exposed to static electricity discharge.
- k. Locations where strong high frequency is generated.
- l. Locations that are subject to potential lightning strikes.
- m. In an area where the product may receive direct impact or vibration.
- n. Areas where the product may be subjected to forces or weight that could cause physical deformation.

## Maintenance

### **Warning**

#### **1) Perform maintenance regularly and clean the emitters.**

It is recommended to perform maintenance every week or when the maintenance (NDL) LED turns ON.

Check regularly that the product is not operating with undetected failures. The maintenance must be performed by an operator who has sufficient knowledge and experience. If the product is used for an extended period of time with dust present on the emitters, the product's ability to eliminate static electricity will be reduced.

If the emitter becomes worn and the product's ability to eliminate static electricity is not restored after cleaning, replace the emitter cartridge.



#### **High voltage caution**

A high voltage generating circuit is mounted onto this product. Verify that the power supply is OFF when performing maintenance. Never disassemble or modify the product, as this can cause loss of product functionality, and there is also a risk of electric shock and earth leakage.

#### **2) Cleaning or replacing the emitters should never be performed while the product power supply is on.**

Fan rotates due to inertial force even when supply power is stopped. Confirm that the fan does not move before performing cleaning or replacing the emitters.

Never perform cleaning or replacing the emitters when the product is energized. The fan rotation may cause injury.

If the emitter is touched while the product is energized, it may cause an electric shock or accident.

#### **3) Do not disassemble or modify the product.**

Disassembling or modifying the product may cause accidents such as electric shock, failure or fire. The product will not be guaranteed if it is disassembled and/or modified.

#### **4) Do not operate the product with wet hands.**

Never operate the product with wet hands. It may cause electric shock or other accidents.

### **Caution**

#### **1) Do not drop, hit or apply excessive shock (100m/s<sup>2</sup> or more) to the product when handling it.**

Even if the ionizer body is not damaged, the internal components may be damaged, leading to a malfunction.

# 1. How to Order

## 1-1. Ionizer

**IZF** □ - □ - □ □ □ □

Fan type

Symbol	Max. air flow
21	1.8 m <sup>3</sup> /min
31	4.4 m <sup>3</sup> /min

Model

**Input/Output specifications**

Nil	NPN Input/output
P	PNP Input/output

**Power supply cable, AC adapter**

Nil	with Power supply cable (3m)
Z	with Power supply cable (10m)
Q	with AC adapter (with AC cord)
R	with AC adapter (without AC cord)
N	None

Filter

Nil	None
U	with Filter

**Automatic cleaning unit, Louver**

Nil	None
S	with Automatic cleaning unit
W	with Louver
Y	with Automatic cleaning unit and Louver

Bracket

Nil	None
B	with Bracket



## 1-2. Accessories

### Emitter cartridge

**IZF** □ - NT

Model

21	For IZF21
31	For IZF31



### Power supply cable

**IZS41 - C** □

**Power supply cable**

P	Power supply cable (3m)
PZ	Power supply cable (10m)



Made to Order

How to Order	Contents/Specifications										
<p>IZS41 - CP □ - X13</p> <p>Power supply cable length</p> <table border="1"> <tbody> <tr> <td>01</td> <td>Total length: 1m</td> </tr> <tr> <td>02</td> <td>Total length: 2m</td> </tr> <tr> <td>.....</td> <td>.....</td> </tr> <tr> <td>19</td> <td>Total length: 19m</td> </tr> <tr> <td>20</td> <td>Total length: 20m</td> </tr> </tbody> </table>	01	Total length: 1m	02	Total length: 2m	.....	.....	19	Total length: 19m	20	Total length: 20m	<p>Made to order power supply cable Available in a unit of 1 meter from 1 to 20m. Note: For 3m and 10m, use a standard product.</p>
01	Total length: 1m										
02	Total length: 2m										
.....	.....										
19	Total length: 19m										
20	Total length: 20m										



**AC adapter**

**IZF21 - C□**

**AC adapter**

G1	AC adapter (with AC cord)
G2	AC adapter (without AC cord)

Note) AC cord is only for use in Japan (Rated voltage: 100 to 240 V, Plug: JIS C8303, Inlet: IEC60320-C6). External input and output cannot be used when the AC adapter is being used.



AC adapter



AC cord

**Bracket**

**IZF□ - B1**

Model	
21	For IZF21
31	For IZF31

4 retaining bolts are included.



**Automatic cleaning unit, Louver**

**IZF□ - H□**

**Automatic cleaning unit, Louver**

S	Automatic cleaning unit
W	Louver

Model	
21	For IZF21
31	For IZF31



Automatic cleaning unit



Louver

**Air adsorption side filter**

**IZF□ - F□**

**Air adsorption side filter**

L	Filter
U	Filter and Filter holder

Model	
21	For IZF21
31	For IZF31



1-3. Option

**Cleaning arm (for automatic cleaning unit)**

**IZF□ – M3**

Model	
21	For IZF21
31	For IZF31



**Cleaning kit**

**IZS30-M2**

(Provided together with 1 felt pad grindstone, 1 rubber grindstone, and 2 replacement felt pads)



**IZS30-A0201**

(Provided together with 10 replacement felt pads)



**IZS30-A0202**

(Provided together with 1 replacement rubber grindstone)



**Driver for ion balance adjustment trimmer**

**IZS30-M1**



**2. Procedures to Operation**

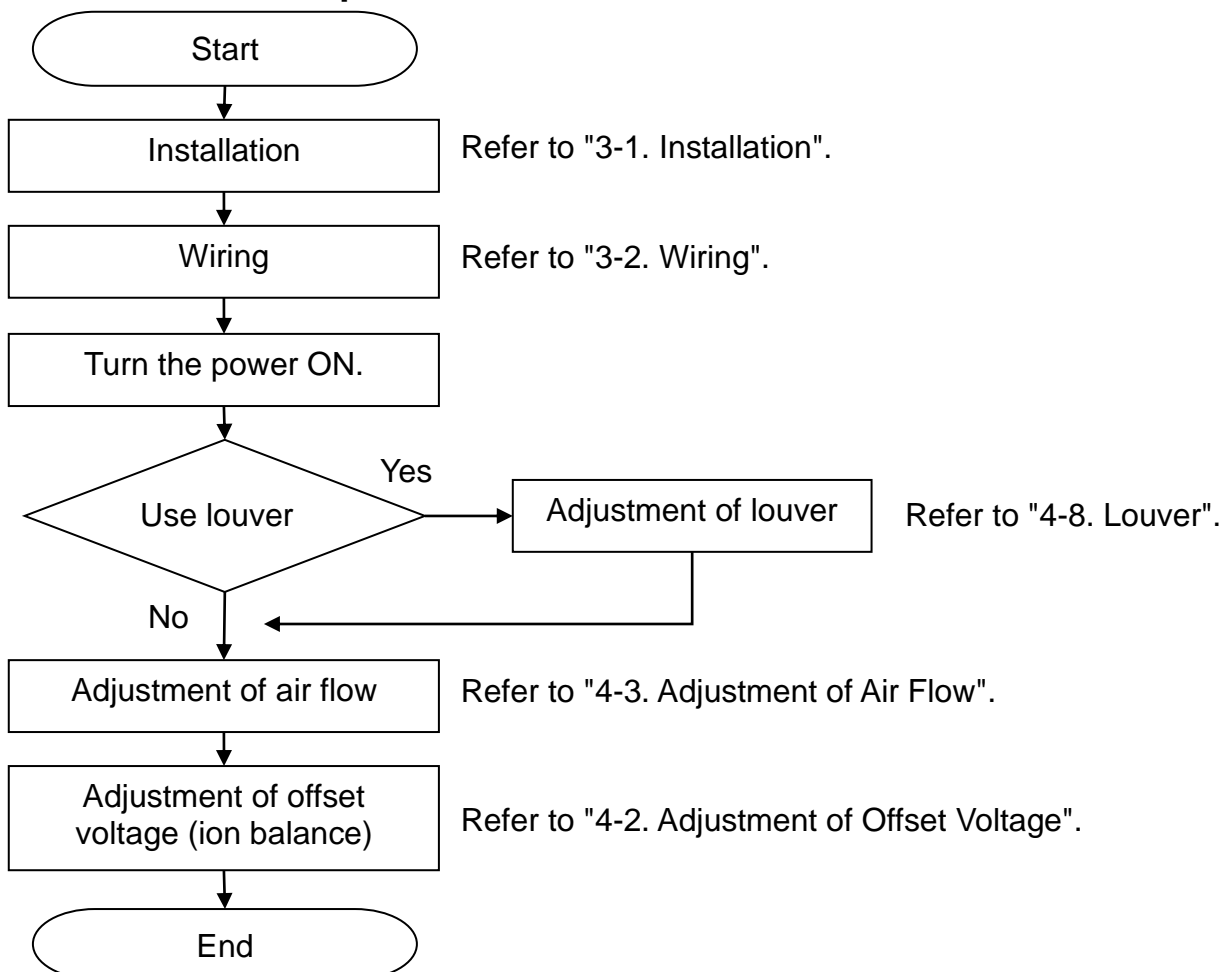

### 3. Installation and Wiring

Do not install the Ionizer in a place where static electricity or noise is generated.

The effect of the static neutralization varies depending on the surrounding installation and operating conditions. Confirm the effect of the static neutralization after installation.

#### 3-1 Installation

##### 3-1-1. Precautions for Installation

Be sure to cut off the power supply before installing the product.

Do not adhere tape or sticker onto the product body. If the tape or sticker contains conductive adhesive or reflective paint, it is possible that due to the dielectric effect, charge could build up causing an electro-static discharge or electrical leakage.

When installing the Ionizer, ensure the air adsorption side of the product is at least 20mm (for IZF21) or 30 mm (for IZF31) away from any walls or obstacles. If there is an obstacle such as wall on the air adsorption side of the product, the static neutralization capacity will be reduced due to ventilation resistance.

The emitter cartridge can be mounted/removed with one touch. However, it is possible to secure it with a screw as necessary. To secure the emitter cartridge with a screw, use an M3 x 0.5 12mm cross recessed round head screw (The screw needs to be prepared by the user). M3 screw recommended tightening torque is 0.25 to 0.35 Nm.

Install the ionizer so that the emitter cartridge can be removed for maintenance and replacement of the emitters.

To remove the emitters for cleaning or replacement, pull it to the air blow side while the part A of the emitter cartridge is being pressed. (If the emitter cartridge is secured with a retaining screw, remove the screw before removing the emitter cartridge.)

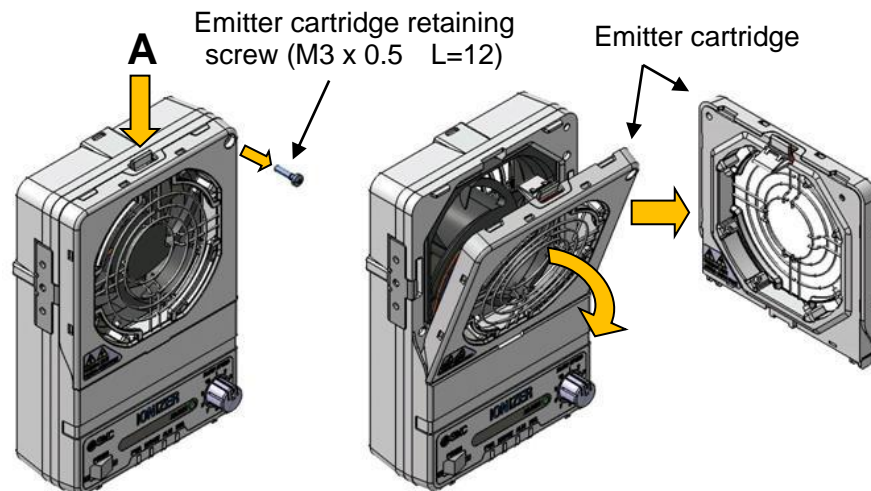

Do not directly touch the emitters with your finger or tools. It may prick your finger and result in injury. Also, if the tool damages the emitters, it may interfere with the specified function and performance, and may also cause operation failure and accident.

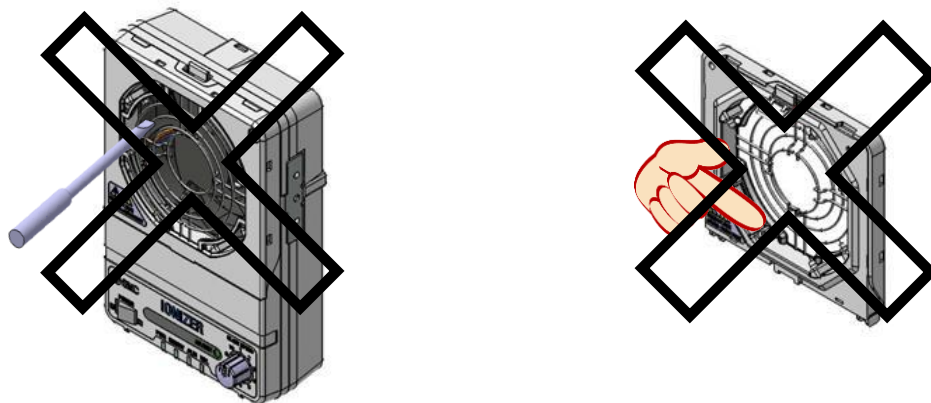

High voltage caution

High voltage is applied to the emitters. Never touch the emitters. It may cause electrical shock.

### 3-1-2. Installation of Ionizer

#### 1) Installation with bracket

When installing the ionizer with a bracket, secure it with M5 screws using the mounting holes on the bottom of the bracket (The screws need to be prepared by the user).

Refer to "6. Dimensions" for details.

The angle adjustment range of the bracket is 45 degrees in direction A, and 90 degrees in direction B.

Direction B: 90°

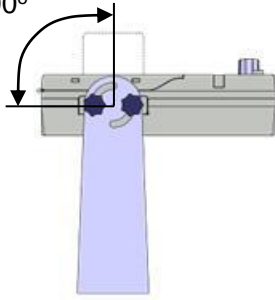

Direction A: 45°

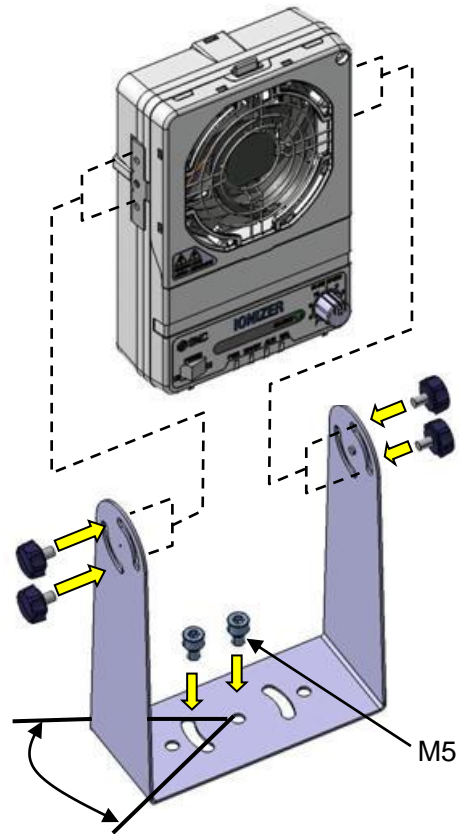

#### 2) Installation without bracket

If a bracket is not used, install the product using the M4 screw holes on both sides of the body. Make sure to secure both sides of the body when fixing the ionizer. (If the product is fixed by one side only, the product body may be broken. The screws need to be prepared by the user.)

Refer to "6. Dimensions" for details.

M4 screw recommended tightening torque is 1.3 to 1.5 Nm.

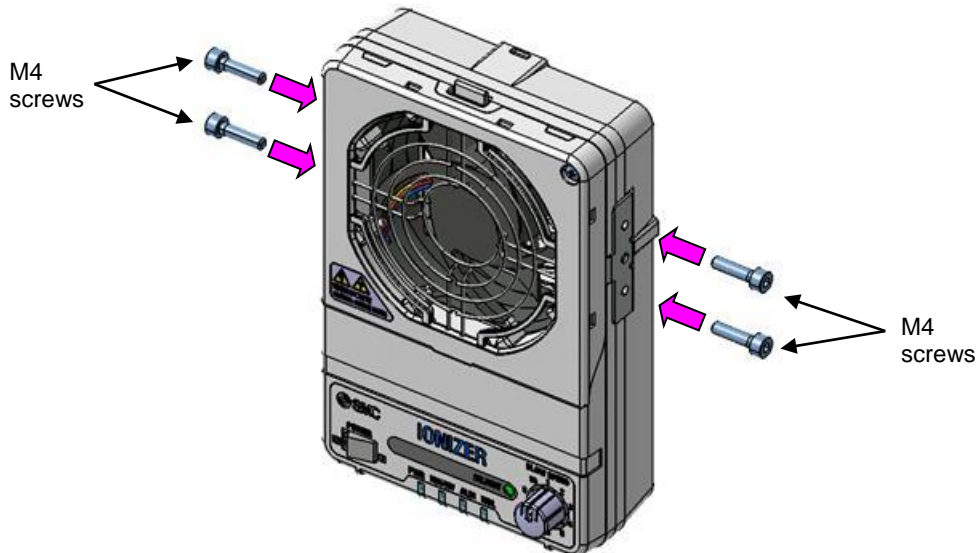

### 3-2. Wiring

#### 3-2-1. Connection Circuit

Wire cables according to the connection circuit and wiring chart.  
 Make sure to ground the ground terminal (F.G.) with a ground resistance of 100Ω or less.

The ground terminal (F.G.) is used as a reference electric potential for static neutralization. If the ground terminal is not grounded, the Ionizer will not be able to achieve the optimal offset voltage (ion balance).

In addition, make sure to wire 2 brown cables and 2 blue cables for supplying power to the Ionizer.

#### Connection circuit

NPN Input/output

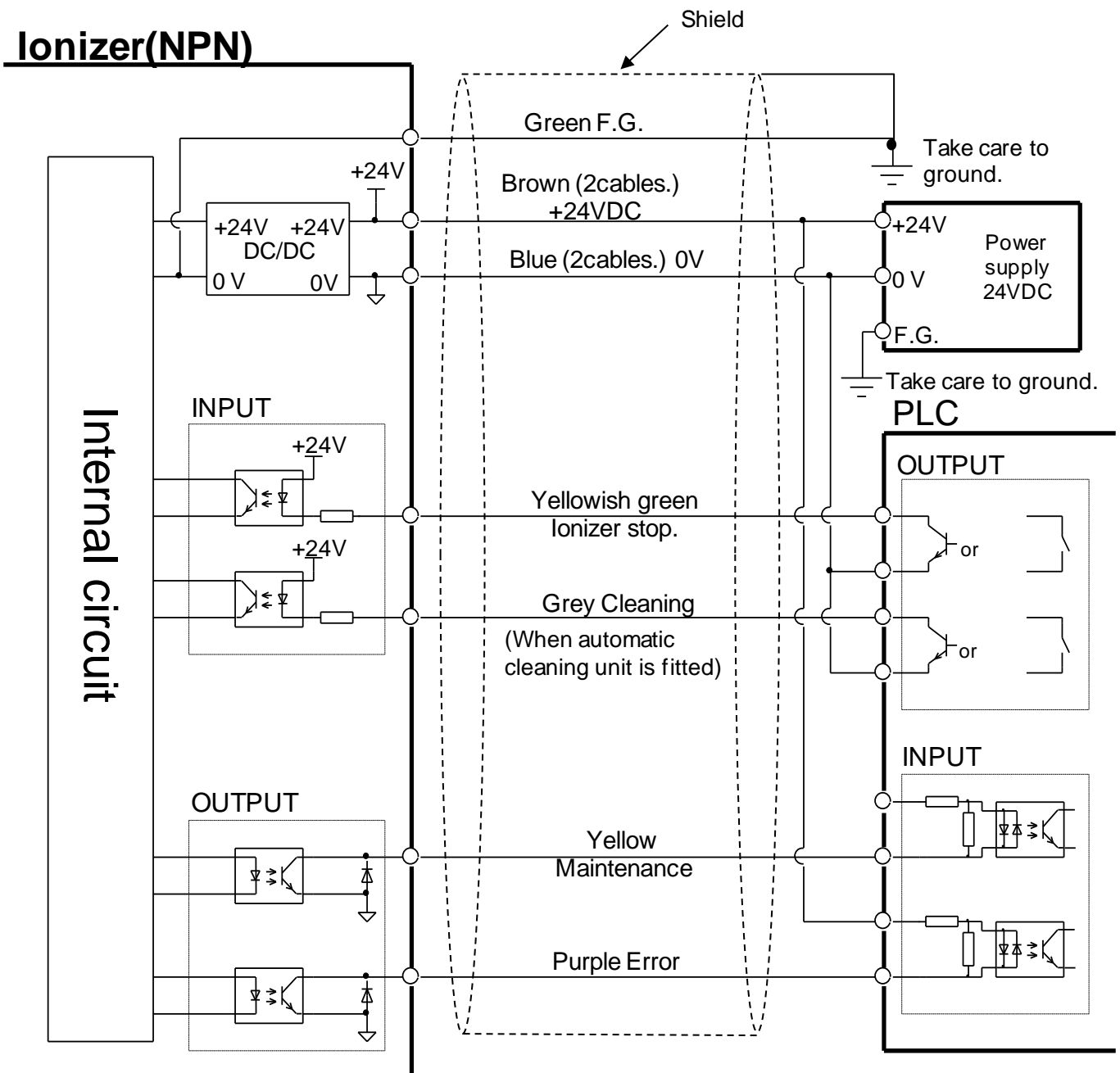

PNP Input/output

# Ionizer(PNP)

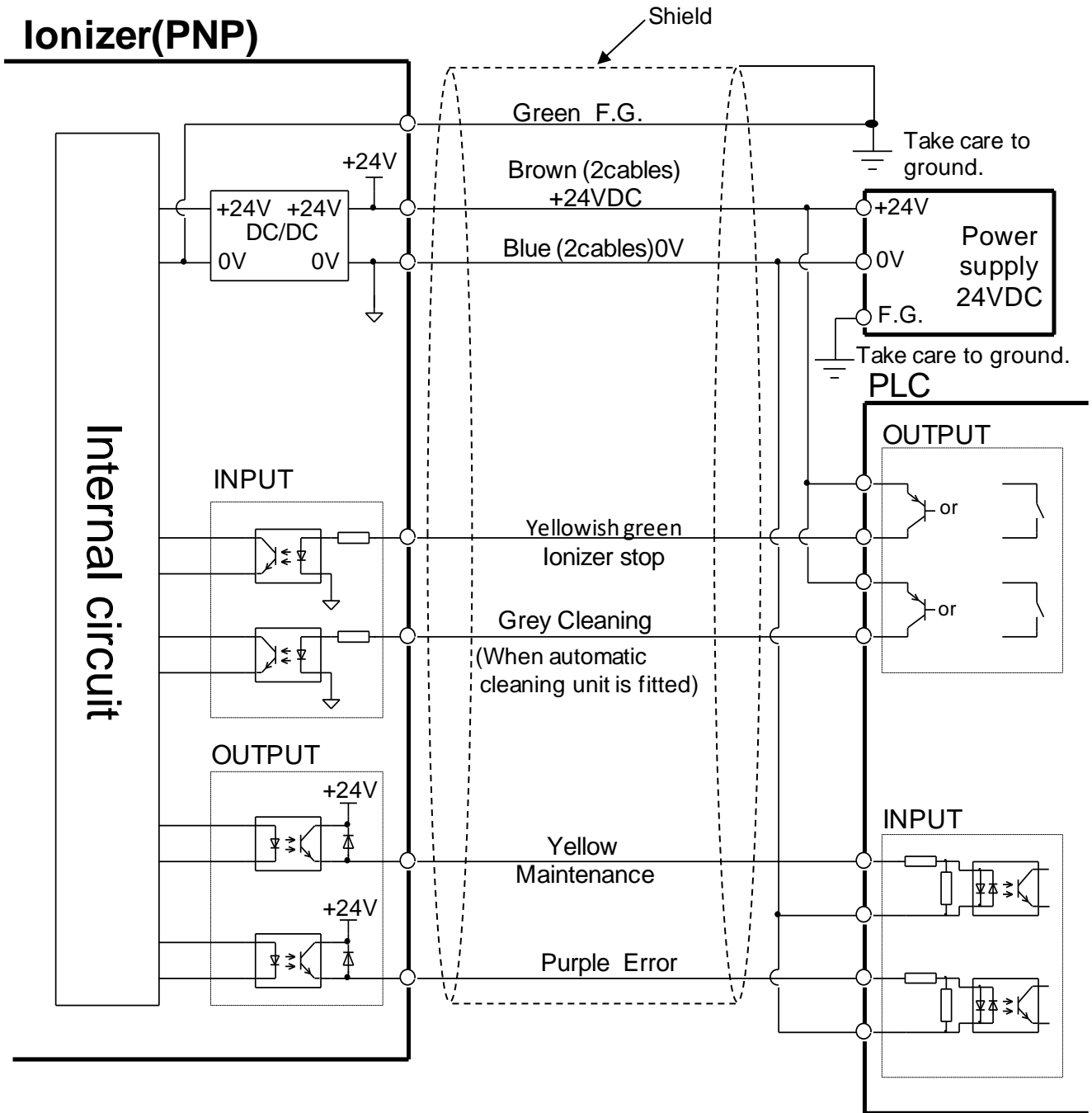

### 3-2-2. Wiring of the Power Supply Cable

Fix the cables with more than the minimum bending radius to prevent an excessive stress from being applied to the cables and/or connectors.

Minimum bend radius: 38 mm

Note: This is an allowable bend radius at 20°C.

Unused electric wires should be cut short or insulated to avoid contacting with other electric wires.

To satisfy the current capacity, make sure to wire 2 brown cables in which a voltage of 24 VDC is supplied and 2 blue cables in which 0V is connected.

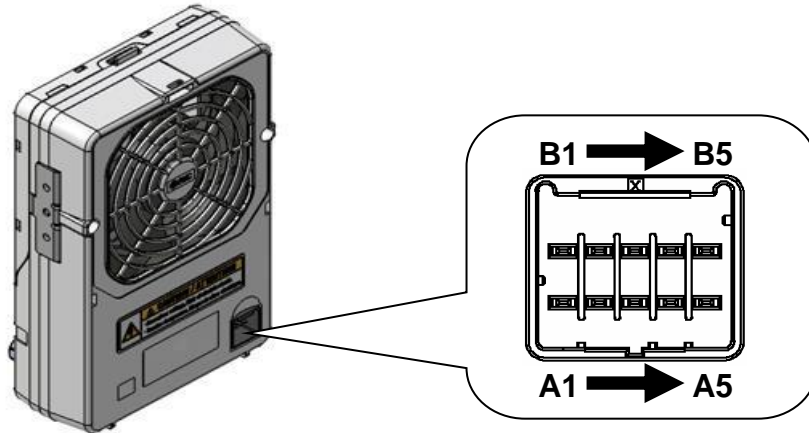

#### Wiring

Connector pin No.	Cable color	Signal name	Signal direction	Description
A1	Brown	24 VDC	IN	Connect power supply to operate the Ionizer.
B1				
A2	Blue	0 V	IN	
B2				
A3	Green	F.G.	-	Make sure to ground with a resistance of 100Ω or less to use it as a reference electric potential for Ionizer.
B3	Yellowish green	Ionizer stop signal	IN	Signal input to turn ON/OFF the ventilation with fan and ion generation. NPN specification: Ventilation and ion generation is stopped by connecting to 0 V. (It operates when disconnected) PNP specification: Ventilation and ion generation is stopped by connecting to +24 VDC. (It operates when disconnected)
A4	Grey	Cleaning signal	IN	If an automatic cleaning unit (option) is mounted, emitters are cleaned by inputting the signal. The ion generation and fan motor rotation are stopped during cleaning.
B4	Yellow	Maintenance signal	OUT (Contact A)	Turns ON when contamination or wear of the emitter is detected, when balance cannot be adjusted by the built-in sensor, or when the automatic cleaning is performed (for product with an automatic cleaning unit).
A5	Purple	Error signal	OUT (Contact B)	Turns OFF when power supply failure, incorrect high voltage, fan motor failure, CPU failure, excessive current of the output circuit, emitter cartridge mounting failure, or automatic cleaning failure (for product with an automatic cleaning unit) is detected. (ON when there is no problem)
B5	White	Unused	-	-

### 3-2-3. Wiring of the AC Adapter

Perform F.G. connecting with the ground terminal (F.G.) of the AC cord when AC adapter is used. If the AC cord is plugged in, plug it into a grounded outlet. Use an AC cord with ground terminal if it is prepared by the user.

The ground terminal (F.G.) is used as a reference electric potential for static neutralization. If the ground terminal is not grounded, the Ionizer will not be able to achieve the optimal offset voltage (ion balance).





### 3-3. Timingchart

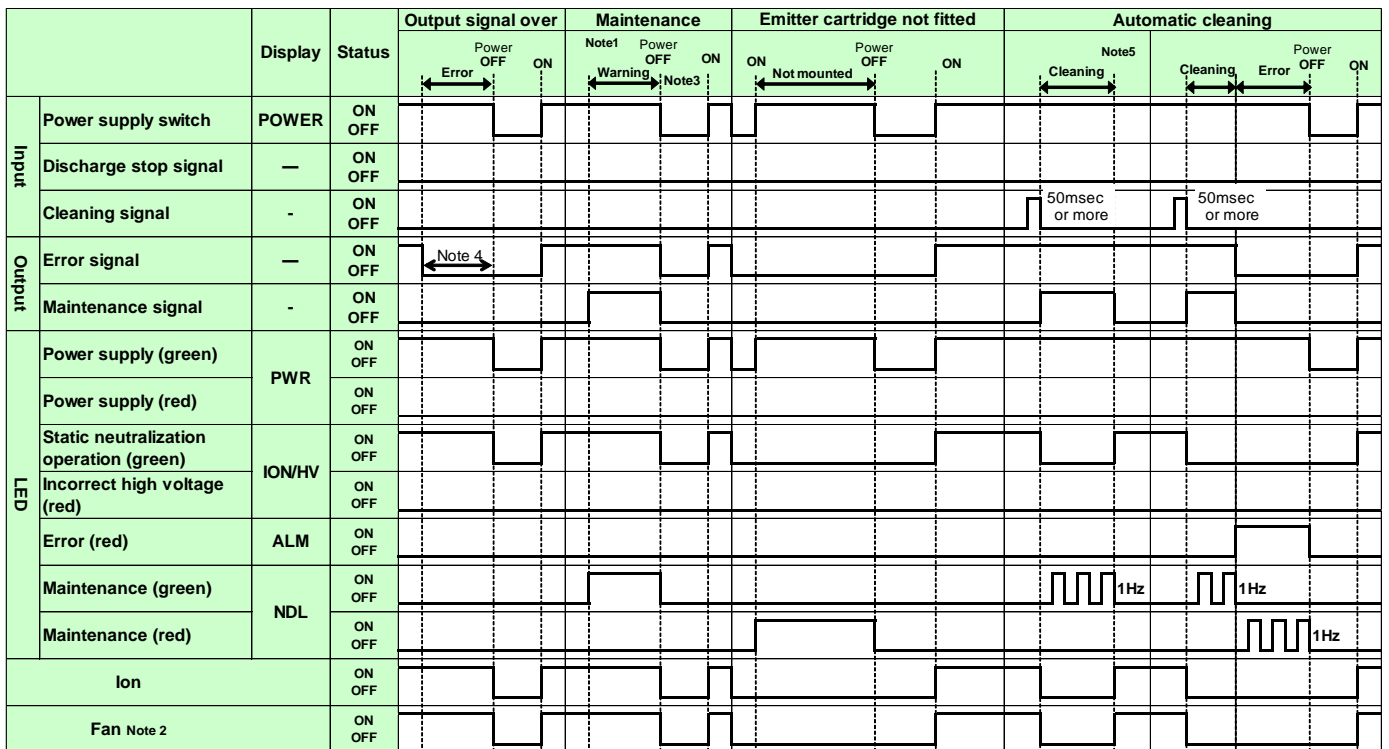
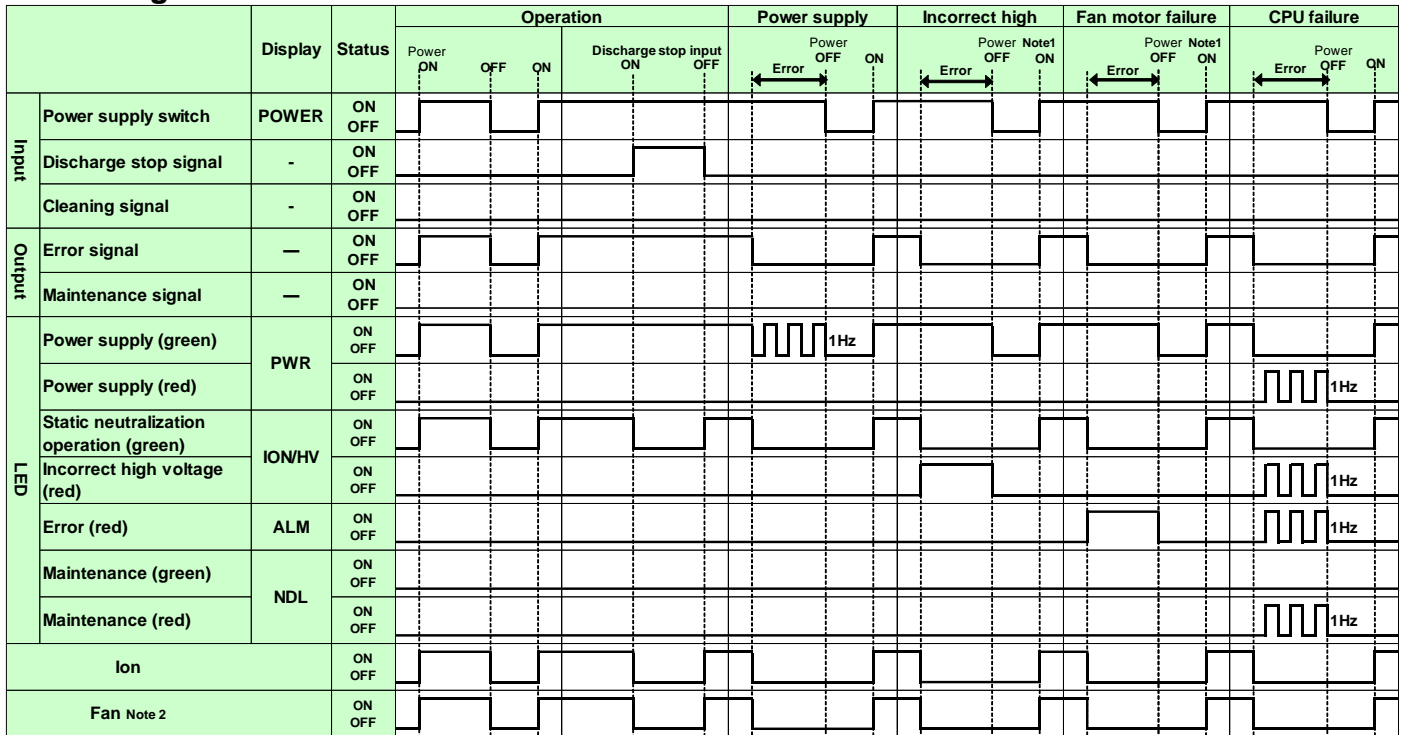

Note 1: Incorrect high voltage, fan motor failure, and maintenance indication can be released by the Ionizer stop signal as well. Release the error after recovery.

Note 2: Fan motor rotation does not stop immediately due to inertial force even when supplying power is stopped.

Note 3: Ensure the power supply is turned off before clearing errors or cleaning emitters.

If an alarm continues to be generated even after cleaning, the emitters may be worn-out or damaged. If wear or damage of the emitters is detected, replace the emitter cartridge with a new one.

Note 4: When over current flows to the error signal or maintenance signal, the signal will be turned OFF to protect the output circuit.

Note 5: The cleaning time is approximately 2 seconds.



## 4. Function

### 4-1. Name of Parts

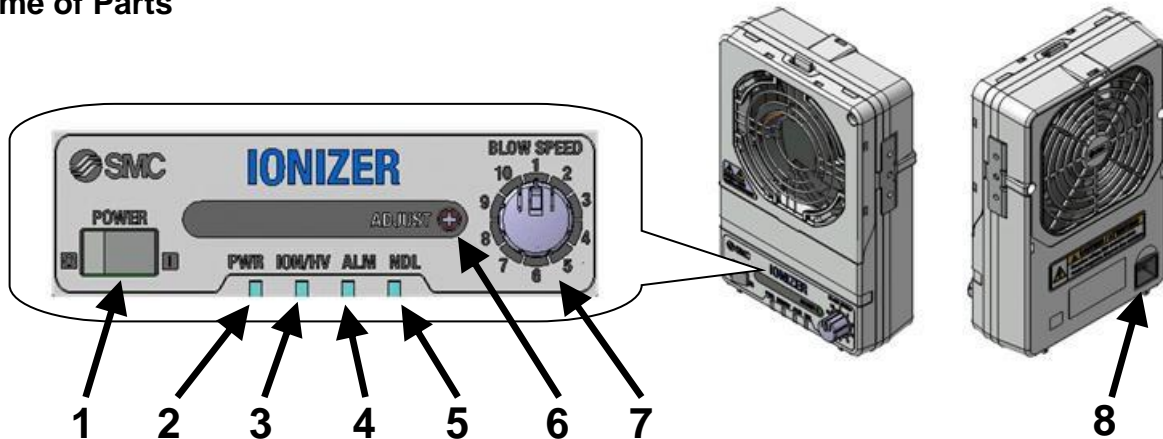

No.	Name	Panel display	Type	Description
1	Power supply switch	POWER	Switch	Turn the Ionizer on and off.
2	Power supply indicator	PWR	LED (Green/ Red)	Green LED lights up when the power supply is ON; green LED flashes when the power supply is abnormal; and red LED flashes when the CPU is abnormal.
3	Static neutralization operation/Incorrect high voltage	ION / HV	LED (Green/ Red)	Green LED lights up when static neutralization is operated; red LED lights up when incorrect high voltage is detected; and red LED flashes when the CPU is abnormal.
4	Error indicator	ALM	LED (Red)	LED lights up all the time during fan motor failure or automatic cleaning failure is detected; and red LED flashes when the CPU is abnormal.
5	Maintenance indicator	NDL	LED (Green/ Red)	Green LED lights up when contamination of the emitters is detected; red LED lights up when emitter cartridge mounting failure is detected; red LED flashes when automatic cleaning failure or CPU failure is detected; and green LED flashes during automatic cleaning is being performed.
6	Balance adjustment	ADJUST	Trimmer	Used for offset voltage (ion balance) adjustment. Refer to "4-2. Adjustment of Offset Voltage" for details.
7	Air flow adjustment	BLOW SPEED	Rotary switch	Used for adjustment of air flow with fan Refer to "4-3. Adjustment of Air Flow" for details.
8	Connector	-	Connector	Connects the power supply, F.G., and input/output.

### 4-2. Adjustment of Offset Voltage

Although the offset voltage (ion balance) of this product has been adjusted before shipping, readjustment may be required depending on the installation environment or conditions. The adjustment can be performed using a balance adjusting trimmer which has an indication of ADJUST.

When adjusting the offset voltage (ion balance), use a measuring instrument such as charge plate monitor.

As described in "4-7-2. Averaging Function", this product exchanges the polarity of voltage applied to the emitters. After adjusting the offset voltage (ion balance), supply power again to exchange the polarity of voltage applied to the emitters. Then, adjust the offset voltage (ion balance) again after rotating the trimmer to the end and returning it. In addition, adjustment of the offset voltage (ion balance) may be required after replacing the emitter cartridge with a new one.

Rotating this balance adjusting trimmer in clockwise direction increases positive ions, and rotating it in counter-clockwise direction increases negative ions.

#### Balance adjusting trimmer

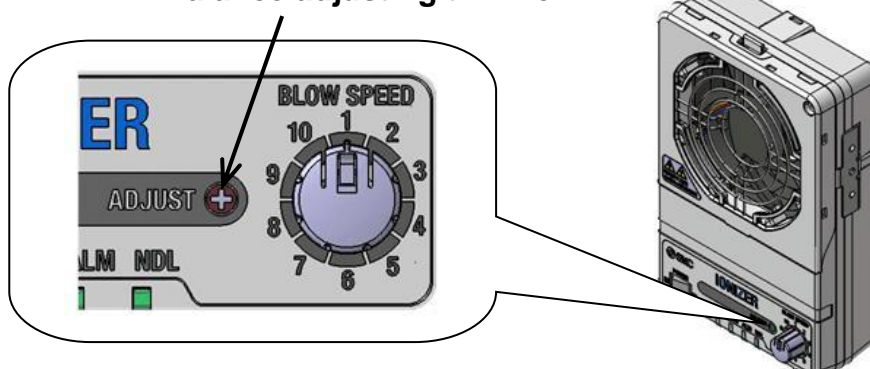

### 4-3. Adjustment of Air Flow

The air flow can be adjusted with an air flow adjustment dial displayed as BLOW SPEED.

The details of the scales of the air flow adjustment dial and the air flow rate are shown in the table below.

SW	Air flow rate [m <sup>3</sup> /min]	
	IZF21	IZF31
1	0.4	1.3
2	0.5	1.7
3	0.6	1.9
4	0.7	2.3
5	0.8	2.5
6	0.9	2.7
7	1.1	3.2
8	1.4	3.7
9	1.7	4.2
10	1.8	4.4

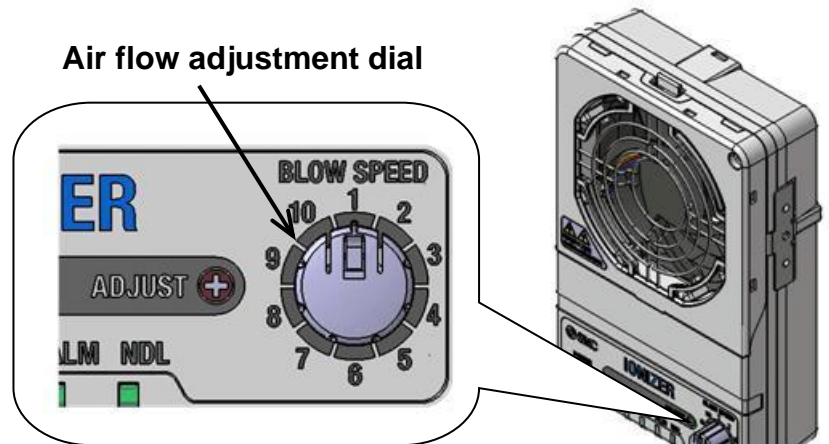

The air flow adjustment dial can be removed to avoid unnecessary setting change

To remove the air flow adjustment dial, pull it out while the part A is being held.

When inserting the air flow adjustment dial, make sure that the D-shaped part of the rotary switch on the body fits into the D-shaped part of the dial mounting part. If the D-shaped part is inserted forcibly while it is not being fit into the appropriate part, the rotary switch or/and air flow adjustment dial may be broken.

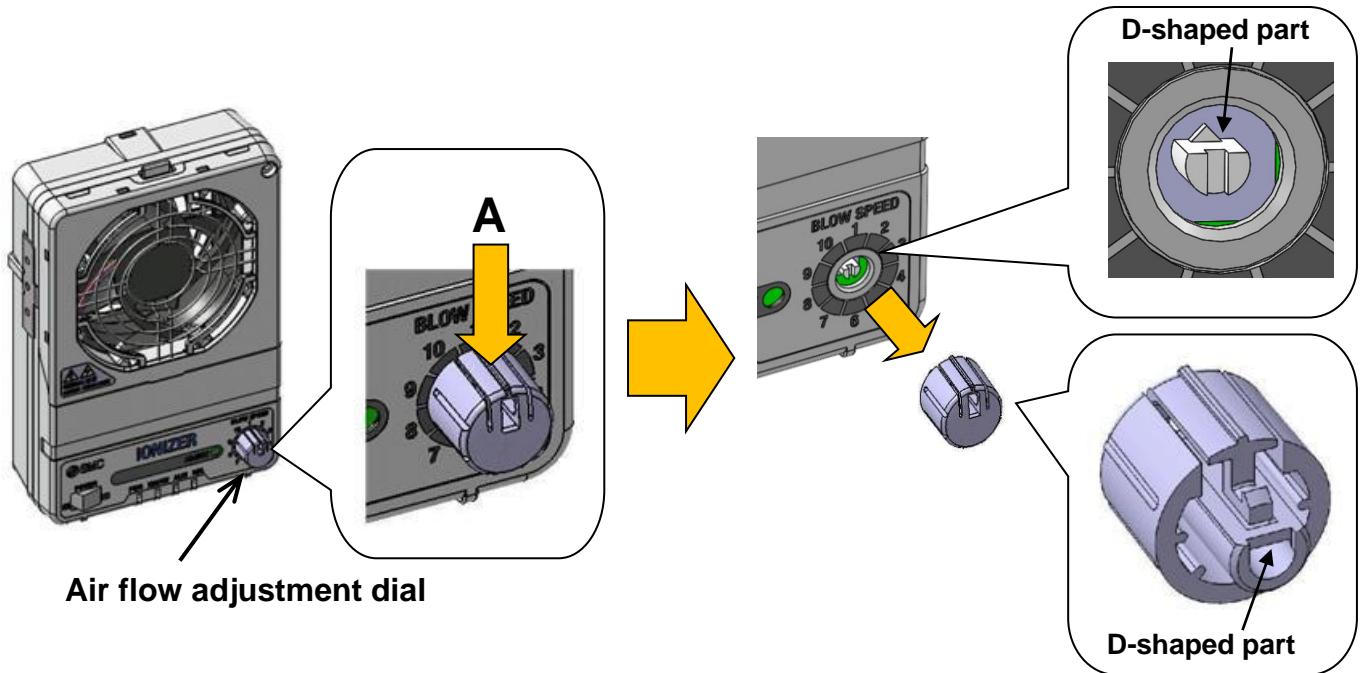

#### 4-4. Emitter Dirt Detection and Cleaning

If the ionizer is used for an extended period of time, contamination such as dust will stick to the emitters, reducing the static neutralization performance.

This product has a function which monitors the emitter contamination all the time. When the emitter contamination is detected, it is indicated by the maintenance signal and LED.

The emitters should be cleaned when contamination is detected, or once a week.

(The cleaning frequency varies depending on the environment where the ionizer is installed.)

The emitters can be cleaned manually or automatically (option).

If the ionizer performance does not recover after cleaning the emitters, it can be assumed that the emitters are damaged or worn out. If wear or damage of the emitters is detected, replace the emitter cartridge with a new one.

##### 4-4-1. Manual Cleaning

Clean the emitters with the cleaning kit [IZS30-M2] or a cotton bud soaked in alcohol.

Before cleaning the emitters, make sure that the power supply is OFF and confirm that the fan motor stops. If the cleaning is performed before the fan motor stops, it may cause injury.

In addition, if the emitters are touched while they are being energized, it may cause electrical shock or accident. As the emitter ends are sharp, be careful not to touch them by hands. Otherwise, it may cause injury.

- Replacement and cleaning of emitter cartridge -

- 1) Turn off the power supply of the ionizer. The fan motor rotation does not stop immediately due to inertial force even when supplying power is stopped. Confirm that it stops before moving the next step.
- 2) As shown in the figure below, remove the emitter cartridge by pulling it out to the air blow side while the part A of the emitter cartridge is being pressed. (If the emitter cartridge is secured with a retaining screw, remove the screw before removing the emitter cartridge.)

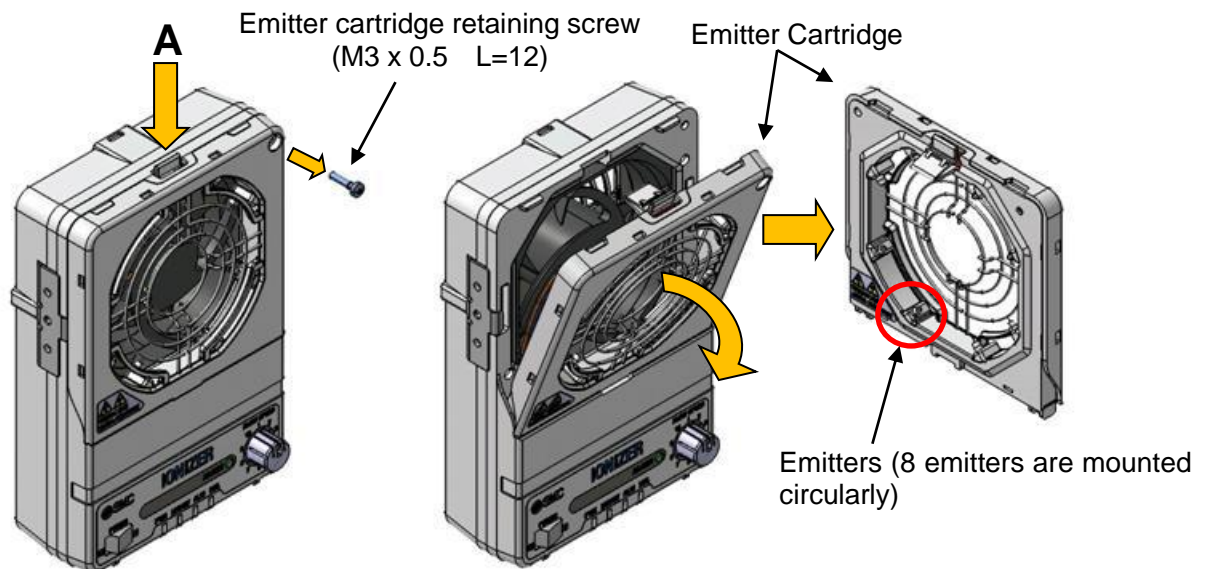

Caution

Do not touch the emitters during cleaning.

- 3) 8 emitters are mounted on the inside of the removed emitter cartridge. Clean all of them. Using the cleaning kit, saturate the felt with industrial alcohol, insert it into the emitters and rotate several times to clean. If the dirt does not come off, use the rubber grindstone to clean the emitters in the same way. After that, again use the felt saturated with industrial alcohol to finish the cleaning. If a cleaning kit is not available, saturate a cotton swab with alcohol to clean the emitters. The industrial alcohol used should be reagent ethanol class 1 99.5vol% or greater.

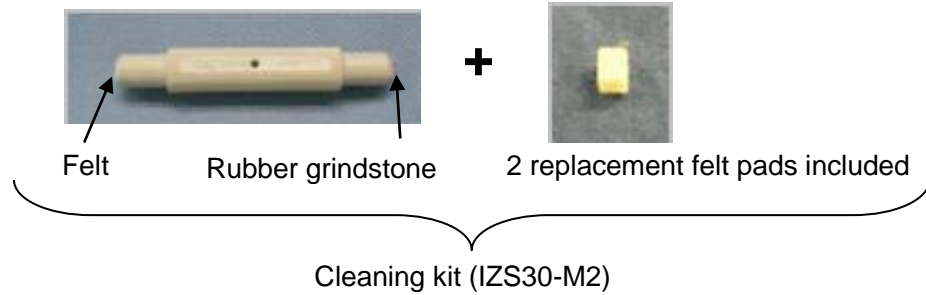

The cleaning kit has a felt pad and a rubber grindstone. Choose the felt or rubber grindstone depending on the level of contamination to effectively clean the emitters.

Felt: Use for normal cleaning.

Rubber grindstone: Use if dirt is hard and stuck to the emitters and it is not possible to remove it with felt.

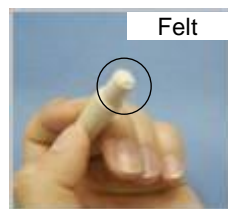

4) Put the emitter cartridge back in its original position by following the removal procedure in reverse.

Remount the emitter cartridge so that the terminals on the body contact with the terminals on the emitter cartridge. Be careful that no contact failure or short circuit caused by adhesion of foreign matter occurs when connecting those terminals. Make sure that no foreign matter is adhered to the connector of the body.

The recommended tightening torque for emitter cartridge retaining screw is 0.25 to 0.35 Nm.

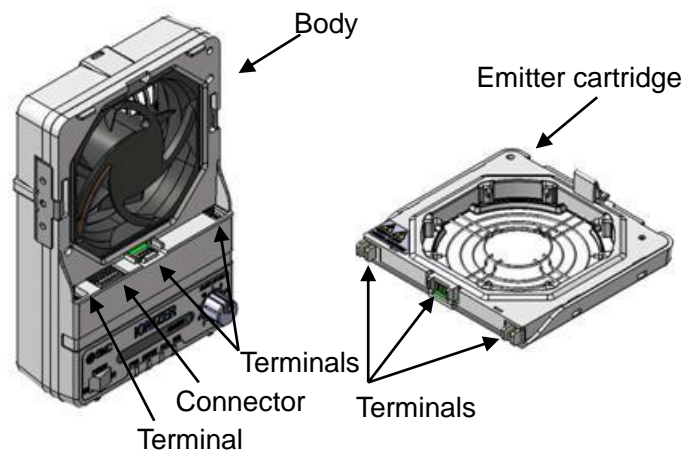

#### 4-4-2. Emitter Cleaning with an Automatic Cleaning Unit (Option)

Cleaning is performed by the cleaning arm mounted on the front surface of the fan.

To start the automatic cleaning, input the cleaning signal or press the operation button.

The ion generation and fan motor are stopped during automatic cleaning.

Do not stop the operation of the cleaning arm mounted between the finger guard and the fan motor during automatic cleaning. Never stop the operation as this may cause breakage. The cleaning time is approximately 2 seconds.

When performing the automatic cleaning by signal input, refer to "3-2 Wiring" and "3-3 Timing Chart".

A magnetic type origin detection sensor is used for controlling the automatic cleaning. Keep magnetic field more than 50 mT away from the ionizer enclosure. If a magnetic field more than 50 mT approaches the ionizer enclosure, the ionizer may malfunction.

If the automatic cleaning stops due to power failure or other reasons, restart the cleaning operation to put the cleaning arm back to the original position.

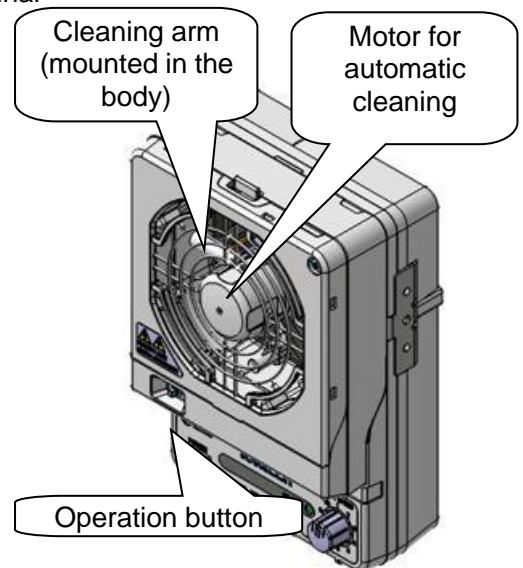



#### 4-4-3. Automatic Cleaning Unit Assembly

The assembly procedure of the automatic cleaning unit is as follows:

- 1) Remove the emitter cartridge from the body referring to "4-5. Replacement of Emitter Cartridge".
- 2) Insert the parts B of the automatic cleaning unit into the parts A of the body.
- 3) Slide the automatic cleaning unit in direction C.

The automatic cleaning unit and the body have terminals for driving the motor for cleaning, terminals for applying high voltage to the emitters, and connector. Be careful that no contact failure or short circuit caused by foreign matter adhered to the terminals occurs when mounting the automatic cleaning unit.

- 4) Secure the body and the automatic cleaning unit with two screws.

The recommended tightening torque for automatic cleaning unit fixing screw is 0.4 to 0.44 Nm.

- 5) Mount the emitter cartridge onto the fixed automatic cleaning unit referring to "4-5. Replacement of Emitter Cartridge".

- 6) After assembling the automatic cleaning unit, start the cleaning operation to put the cleaning arm back to the original position.

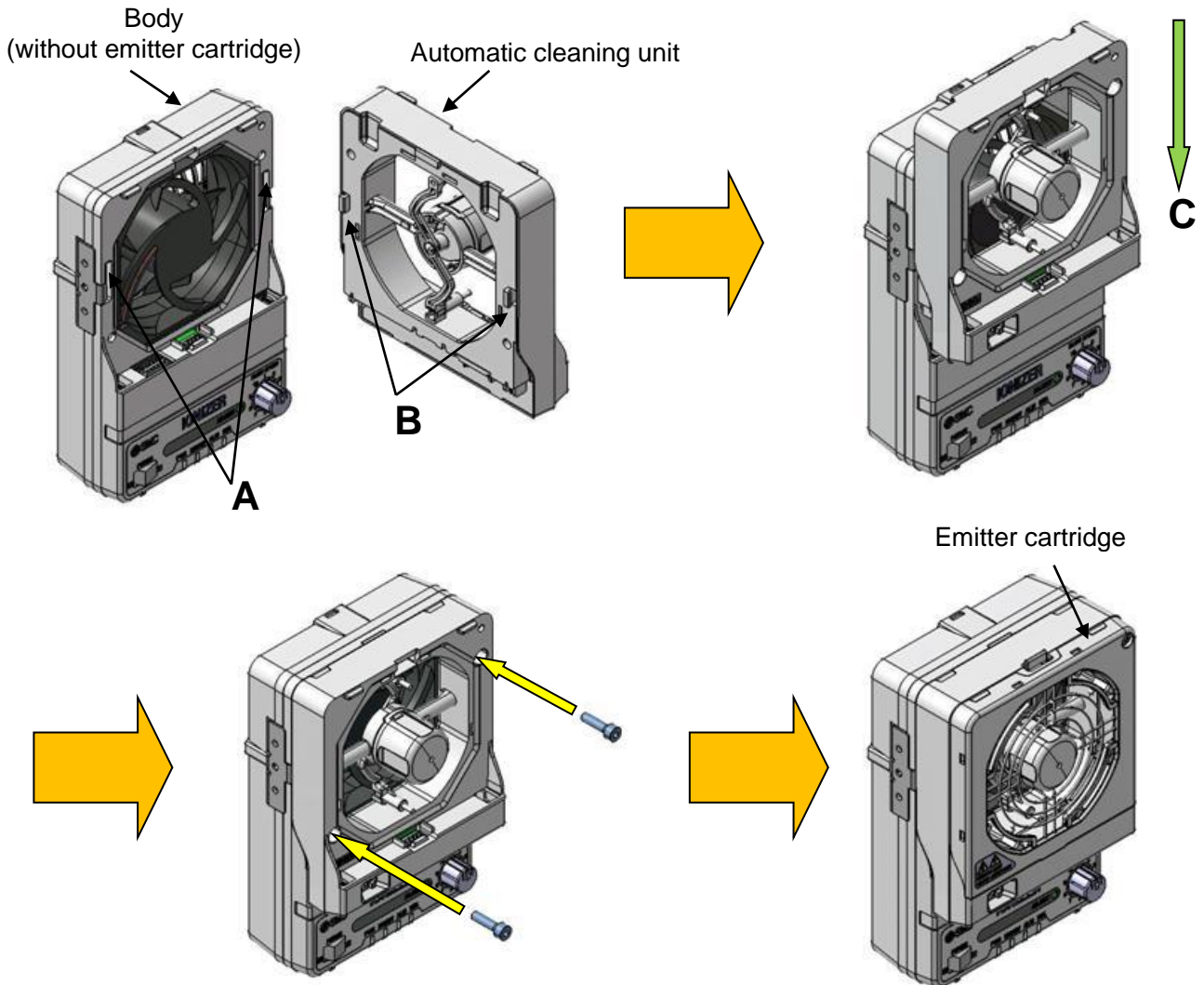

#### 4-4-4. Replacement of Cleaning Arm

The replacement procedure of the cleaning arm mounted on the automatic cleaning unit is as follows:

- 1) Refer to "4-4-3. Automatic Cleaning Unit Assembly", remove the automatic cleaning unit by following the reverse procedure.
  - 2) Hold the motor shaft mounting part of the cleaning arm with a tool such as pliers, and pull it out in A direction while the part B is being held.
  - 3) Align the cleaning arm with the motor shaft so that the arrow part of the cleaning arm to be newly mounted faces toward the D-shaped part of the shaft of the motor for cleaning. Then, insert the cleaning arm by pressing the part C of the cleaning arm and the part F of the automatic cleaning unit.
- If the cleaning arm is inserted forcibly while the arrow part is not fit into D-shaped part, it may break. In addition, if the cleaning arm is inserted by pressing the part C only, the automatic cleaning unit may break.
- 4) Insert the cleaning arm so that the gap between the motor shaft mounting end surface of the cleaning arm and the protrusion of the motor shaft on the automatic cleaning unit enclosure end surface is approximately 1 mm.
  - 5) Mount the automatic cleaning unit onto the body referring to "4-4-3. Automatic Cleaning Unit Assembly".
  - 6) After assembling the cleaning arm, start the cleaning operation once to put the cleaning arm back to the original position.

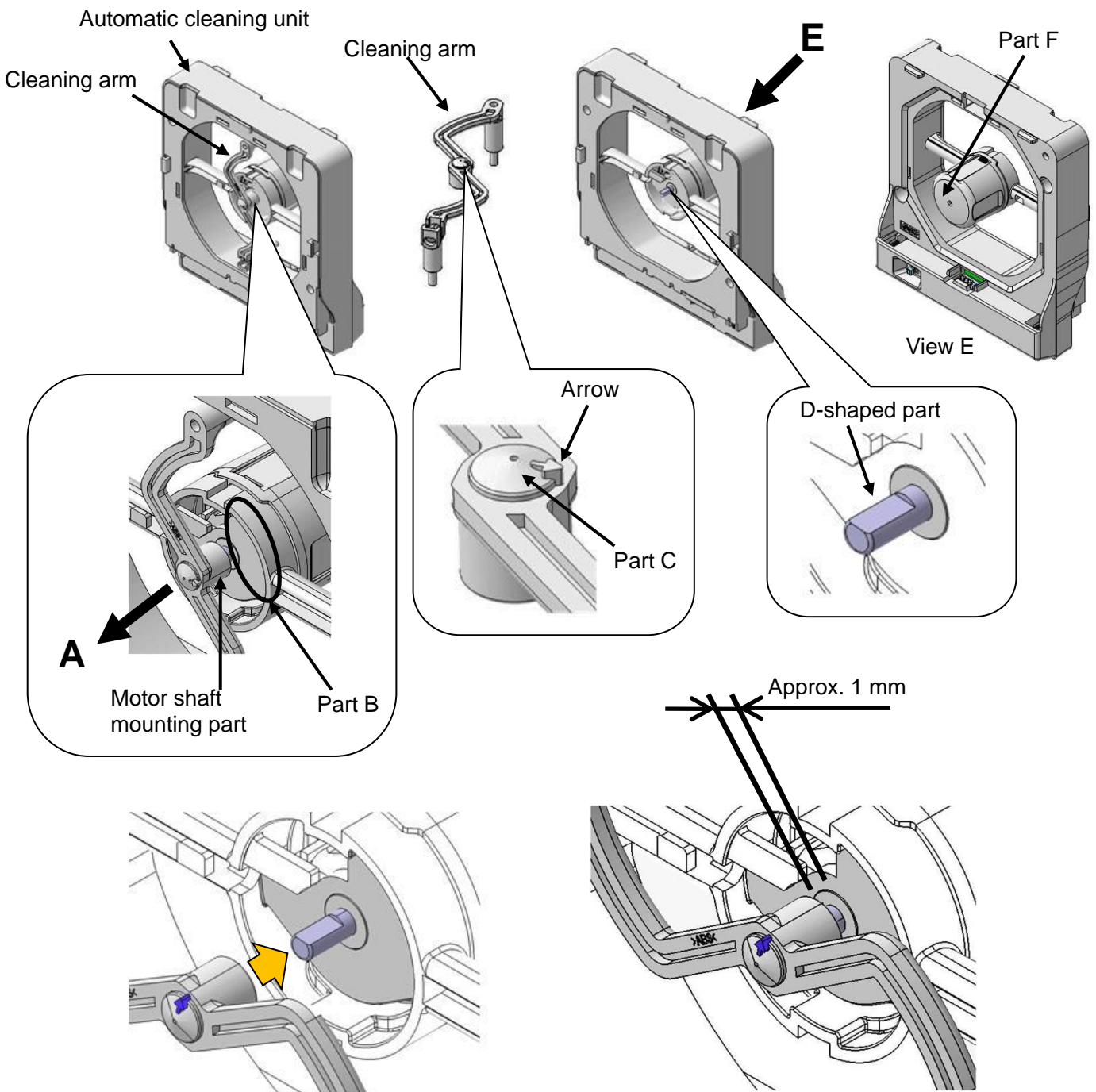

#### 4-5. Replacement of Emitter Cartridge

If the emitters are worn out or damaged, replace the emitter cartridge.

Before replacing the emitters, make sure that the power supply is OFF and confirm that the fan motor stops. Fan motor rotates due to inertial force even when supplying power is stopped. Confirm that the fan stops before performing repair work.

Remove the emitter cartridge by pulling it out to the air blow side while the part A of the emitter cartridge is being pressed. (If the emitter cartridge is secured with a retaining screw, remove the screw before removing the emitter cartridge.)

Remount the emitter cartridge onto the body by following the reverse procedure for removal. As the emitter cartridge and the body have terminals for confirming the connection and for applying high voltage to the emitters, remount the emitter cartridge onto the body so that those terminals contact each other. Be careful that no contact failure or short circuit caused by adhesion of foreign matter occurs when connecting those terminals. Make sure that no foreign matter is adhered to the connector of the body. The recommended tightening torque for emitter cartridge retaining screw is 0.25 to 0.35 Nm.

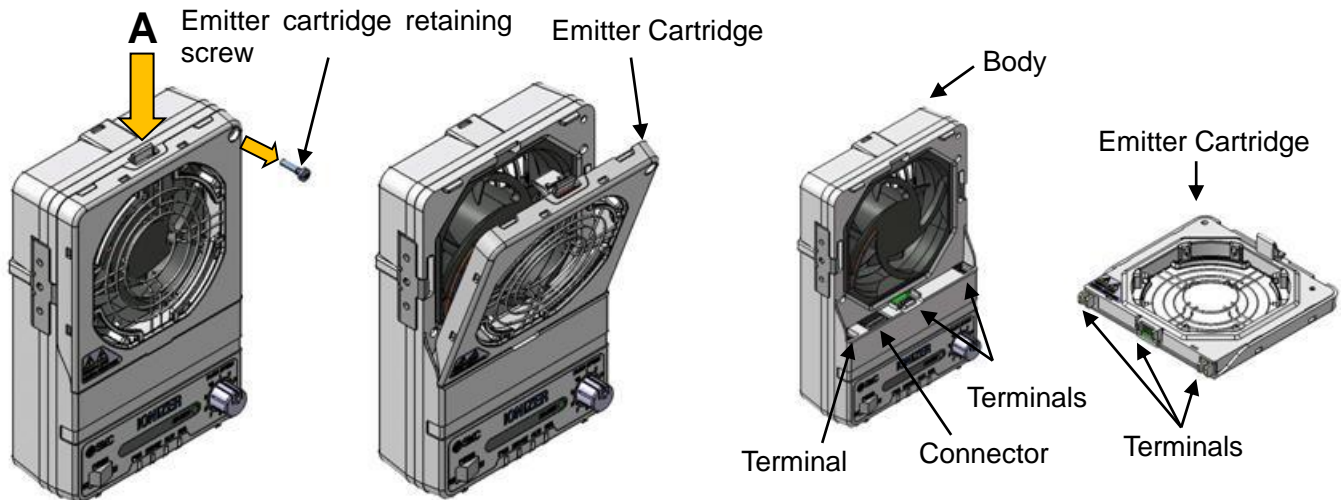

#### 4-6. Alarm Function

If abnormal functioning occurs during operation of the ionizer, the user is alerted by the external output signal or LED operation.

Alarm name	Output signal	LED ON	LED (Flashes at 1Hz)	Ionizer operation after alarm generated	Description	Action to reset alarm
Power supply failure	Error signal OFF(B contact)	N/A	PWR (green)	Stop	Connected power supply voltage is outside of specification.	Reset automatically.
High voltage error	Error signal OFF(B contact)	ION/HV (red)	N/A	Stop	Error in the high voltage discharge circuit.	Cycle ionizer stop signal ON/OFF Cycle power OFF/ON
Fan motor failure	Error signal OFF(B contact)	ALM (red)	-	Stop	Incorrect ionizer operation due to foreign matter in fan motor.	Cycle ionizer stop signal ON/OFF Cycle power OFF/ON
CPU failure	Error signal OFF(B contact)	-	PWR (red) ION/HV (red) ALM (red) NDL (red)	Stop	CPU error due to noise etc.	Cycle power OFF/ON
Output signal over current	Error signal OFF(B contact) Maintenance signal ON(A contact)	-	-	Continue	Protection circuit activated by excess current in the output signal.	Reset automatically.
Maintenance warning	Maintenance signal ON (A contact)	NDL (green)	-	Continue	Static electricity neutralization performance is reduced due to contamination, wear or damage to emitters.	Cycle ionizer stop signal ON/OFF Cycle power OFF/ON
Emitter cartridge not fitted	Error signal OFF(B contact)	NDL(red)	N/A	Stop	Emitter cartridge not fitted	Cycle power OFF/ON
Automatic cleaning function error	Error signal OFF(B contact)	ALM (red)	NDL(red)	Stop	Error during automatic cleaning operation.	Cycle power OFF/ON

##### 1) Power supply failure

When power supply which is connected to the ionizer is not within the range of 24 V +/-10%, the abnormal signal will be turned OFF (ON when it is normal), and the PWR LED (green) will flash to indicate the error.

When the failure occurs, the fan motor rotation and ion generation are stopped.

To resolve the error, reset the product automatically by connecting a power supply which provides a power supply voltage of 24 V +/-10%.

2) Incorrect high voltage

When incorrect electric discharge is generated during the ionizer operation, the abnormal signal will be turned OFF (ON when it is normal), and the ION/HV LED (red) will light up to indicate the error.

When the failure occurs, the fan motor rotation and ion generation are stopped.

The incorrect electric discharge could be caused by condensation or dust on the emitters. To resolve the error, input the ionizer stop signal or supply power again after remedying the cause of the incorrect electric discharge.

3) Fan motor failure

When the fan motor malfunctions during the ionizer operation, the abnormal signal will be turned OFF (ON when it is normal), and the ALM LED (red) will light up to indicate the error.

When the failure occurs, the fan motor rotation and ion generation are stopped.

The fan motor failure could be caused by failure of the rotational operation due to foreign matter entwined the fan motor. To resolve the error, input the ionizer stop signal or supply power again after removing the foreign matter.

4) CPU failure

When CPU makes an abnormal operation due to noise or other reasons, the abnormal signal will be turned OFF (ON when it is normal), and the PWR, ION-HV, ALM, and NDL LED (red) will flash to indicate the error.

When the failure occurs, the fan motor rotation and ion generation are stopped.

To prevent noise, perform the following actions and take countermeasures.

1. Position the ionizer away from the noise source.
2. Route the power line and cable of ionizer separately.
3. Install a noise filter to the power supply of the ionizer.

To resolve the error, supply power again after fixing the cause of the error.

5) Output signal over current

When excessive current flows to the output circuit, the output will be blocked to protect the circuit and the abnormal signal will be turned OFF (ON when it is normal) to indicate the error.

The ionizer operates even when excessive current is generated in the output circuit. To resolve the error, reset the product automatically by reducing the current to the output circuit down to 100 mA or less.

6) Maintenance warning

The maintenance signal is ON when contamination, wear or breakage of the emitters is detected. The NDL LED (green) will light up to indicate that cleaning or replacement of the emitters needs to be performed.

The ionizer operates even when the maintenance warning is generated.

When emitters are contaminated, the error can be solved by cleaning them. However, when they are worn out or damaged, it is necessary to replace the emitter cartridge with a new one. To resolve the error, input the ionizer stop signal or supply power again after remedying the cause of the error.

7) Emitter cartridge mounting failure

When the emitter cartridge is not mounted; when power is supplied while the emitter cartridge is not being mounted onto a correct position; or when the correct emitter cartridge mounting cannot be detected due to foreign matter got caught into the terminals which detect connection of the emitter cartridge, the abnormal signal will be turned OFF (ON when it is normal), and NDL LED (red) will light up to indicate the error.

When the failure occurs, the fan motor rotation and ion generation are stopped. To solve the error, supply power again to the product after remounting the emitter cartridge onto a correct position or removing the foreign matter adhered to the terminals which detect connection of the emitter cartridge.

8) Automatic cleaning failure (for product with an automatic cleaning unit)

When the cleaning does not finish in the specified period of time, the abnormal signal will be turned OFF (ON when it is normal), the ALM LED (red) will light up, and the NDL LED (red) will flash to indicate the error.

The automatic cleaning failure could be caused by operation failure due to foreign matter entwined the cleaning parts or by malfunction of the magnetic type origin detection sensor due to environmental magnetic field. To resolve the error, supply power again after removing the foreign matter or/and magnetic field.



#### 4-7. Offset Voltage Performance Maintaining Function

This product uses corona discharge for ion generation, and DC method for voltage application. Although the ion generation efficiency of the DC method is high, the contamination and/or wear level are different between the plus emitters and minus emitters when the product is used for a long period of time. Therefore, the offset voltage (ion balance) performance will be deteriorated quickly.

As countermeasures against the offset voltage (ion balance) performance deterioration due to contamination or/and wear of the emitters when the ionizer is used for a long period of time, this product has the following functions.

- 1) Ion balance sensor
- 2) Averaging function

##### 4-7-1. Ion Balance Sensor

IZF21 and IZF31 have a built-in sensor to maintain the offset voltage (ion balance) performance in an appropriate condition.

The built-in sensor monitors the ion generated from the ionizer with F.G. and adjusts the amount of supply of the positive and negative ions all the time so that the offset voltage (ion balance) can be maintained in the initial condition automatically.

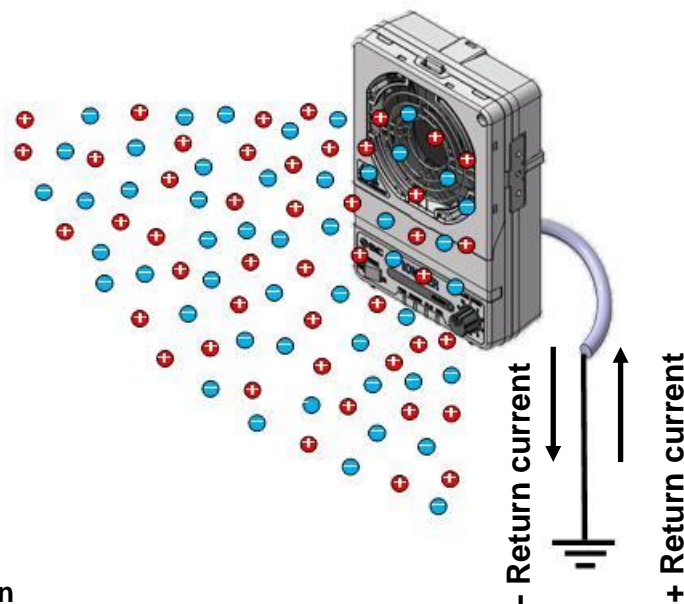

##### 4-7-2. Averaging Function

This product has an averaging function to control the offset voltage (ion balance) performance deterioration caused by difference of contamination or/and wear between the emitters which generates plus ion and the emitters which generates minus ion.

To prevent the offset voltage (ion balance) performance deterioration, the applied voltage to the emitters which generates positive ions and to the emitters which generates negative ions is exchanged so that the contamination or/and wear difference between the emitters are averaged. The voltage applied to the emitters is exchanged every time when power is supplied.

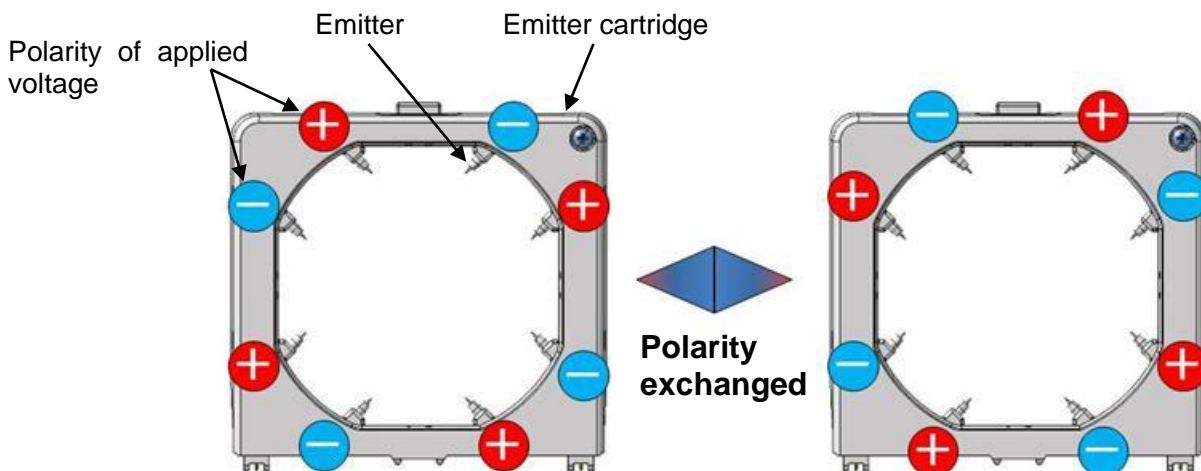

### 4-8. Louver (Option)

By mounting a louver onto this product, the generated ions can be diffused or sent with focusing.

When diffusing the generated ions, the static neutralization area can be wider in one direction by extending the area to an oval area compared to a circular area. When the louver is mounted so that its adjuster moves horizontally, the ionized air spreads out as shown in the figure. The louver can be adjusted in five scales.

Refer to "5. Performance" for the static neutralization performance.

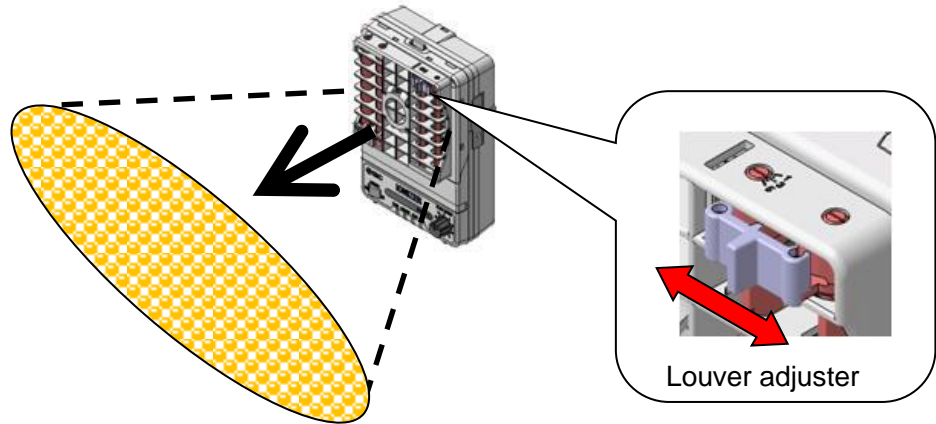

Diffusion image of ionized air with louver

To mount the louver, insert the four attachment features (part A) of the louver into the gaps between the innermost ring of the finger guard and the next ring, and push it into the finger guard. The mounting direction can be changed in 90°.

To remove the louver, insert a tool such as driver into the groove (part B), and push the hook. Be careful not to touch the emitters of the emitter cartridge when removing the louver.

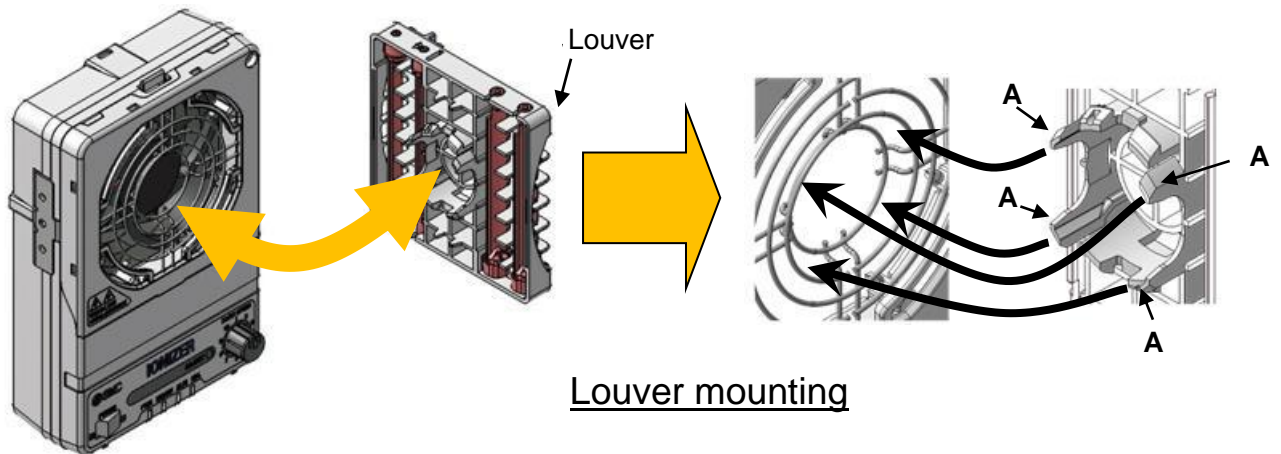

Louver mounting

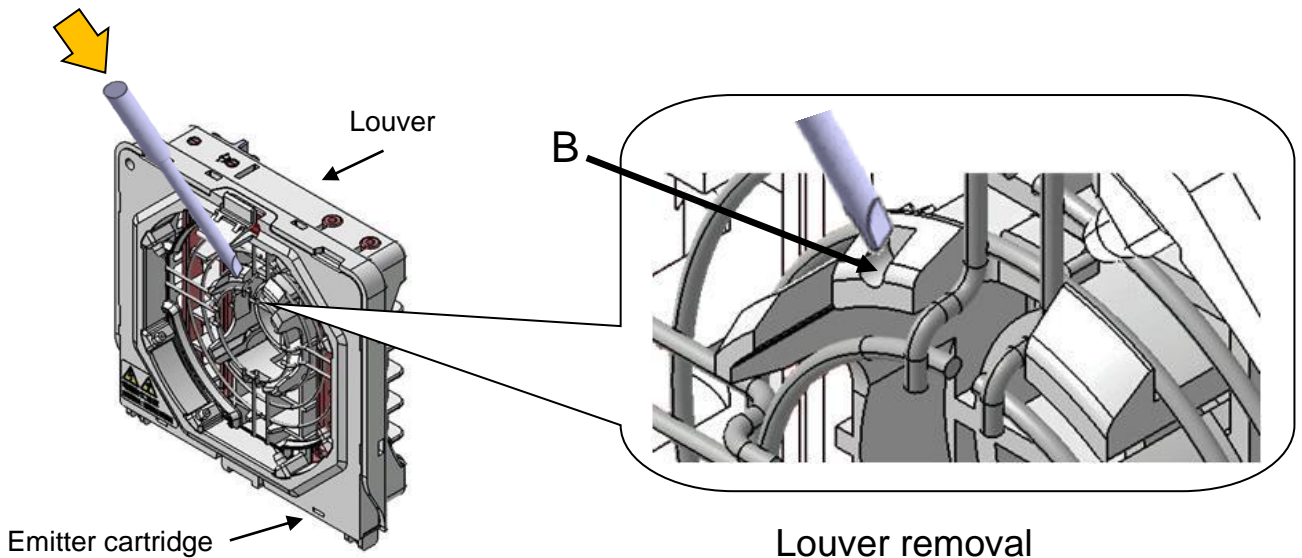

Louver removal

The angle of the louver can be adjusted by sliding the adjuster of the louver. Right and left sides can be adjusted individually depending on the static neutralization area and/or direction.

The indicator shows the adjustment position.

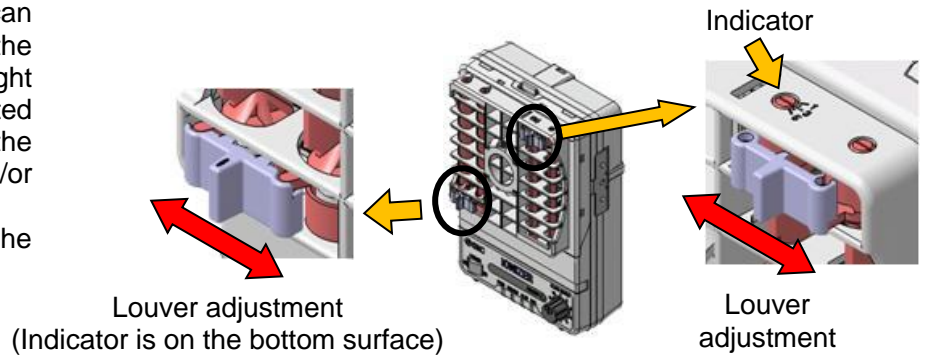

#### 4- 9. Filter (Option)

Filter can be mounted on the air adsorption side of this product.

When the filter is mounted, the static neutralization time will be longer than without filter. Refer to "5. Performance" for details.

To mount the filter, insert the parts B of the filter holder into the grooves (parts A) of the rear side body, and press the filter holder in the C direction using its inserted parts as fulcrums and rotate to attach.

The filter can be cleaned by air blow or washing with water.

When removing the filter from the filter holder, bend the filter to remove it from the filter fixing hooks (4 places) inside of the filter holder. Remounting should be performed by following the reverse procedure of removal.

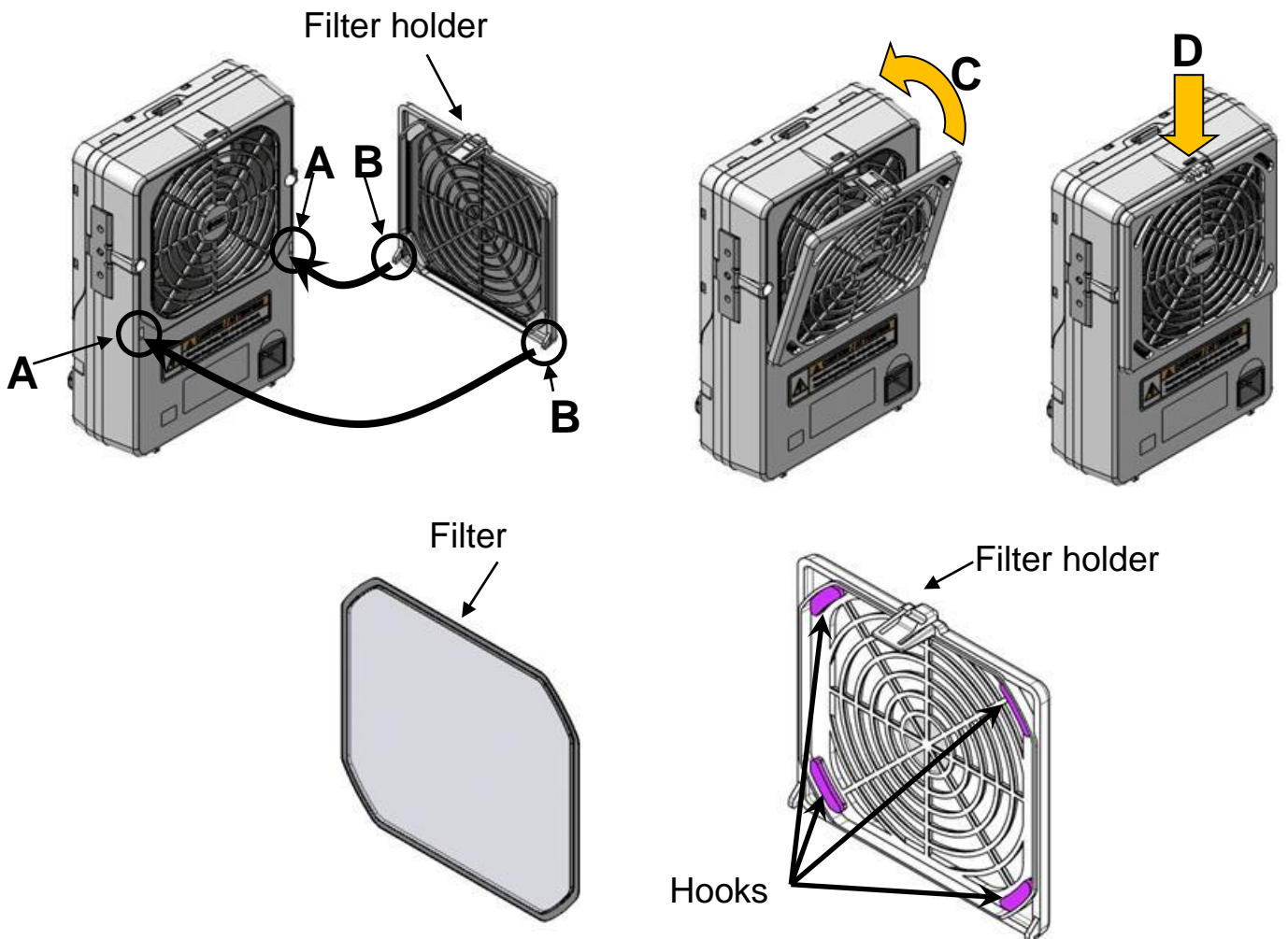

## 5. Performance

Performance data shown in this chapter is based on an electrified plate (dimensions: 150 x 150 mm, electrostatic capacity: 20pF) defined by ANSI standard (ANSI/ESD STM3.1-2006). Use this data as a guideline for selection, as the performance data may vary depending on the material and size of the work piece.

### 5-1. Basic Performance

1) Static neutralization performance (Measured part: Front surface, Discharge time from 1000 V to 100 V)

IZF21

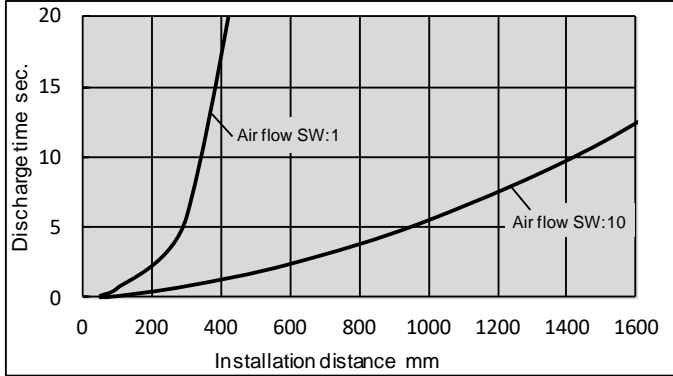

IZF31

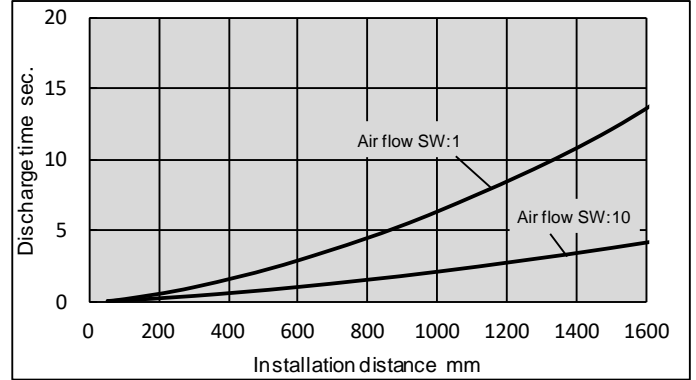

IZF21-S (with Automatic cleaning unit)

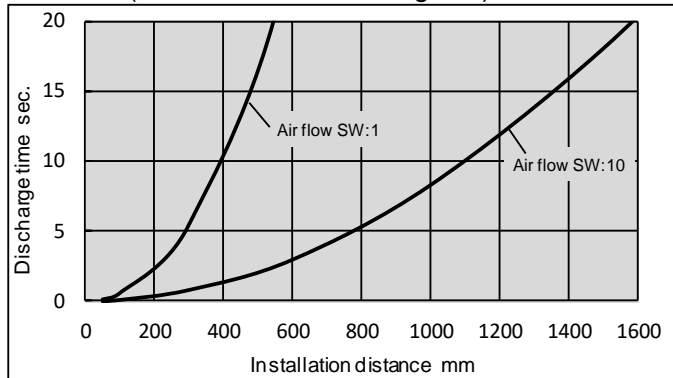

IZF31-S (with Automatic cleaning unit)

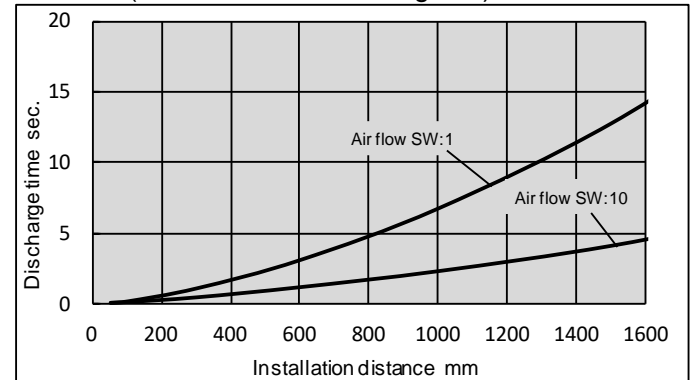

IZF21-U (with Filter)

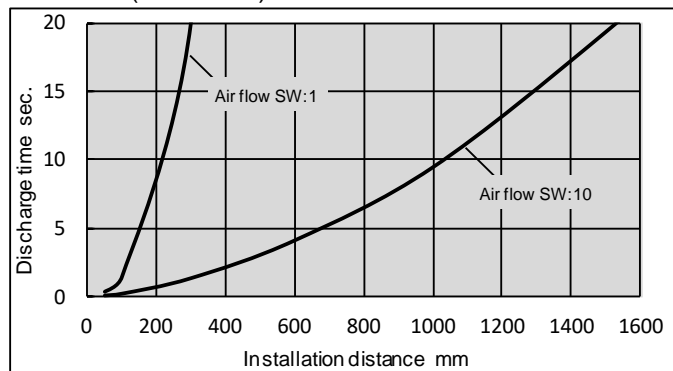

IZF31-U (with Filter)

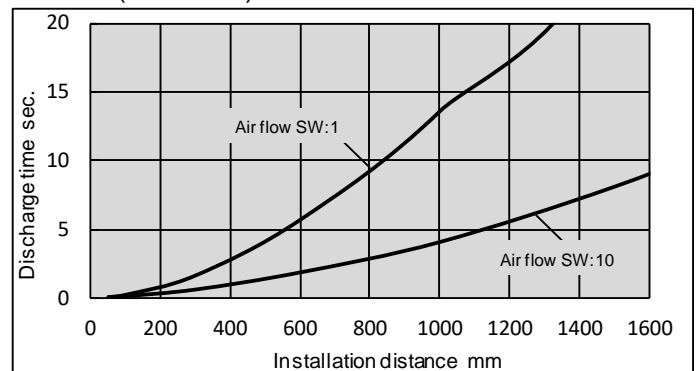

2) Static neutralization area (Air flow setting: 10, Discharge time from 1000 V to 100 V)

IZF21

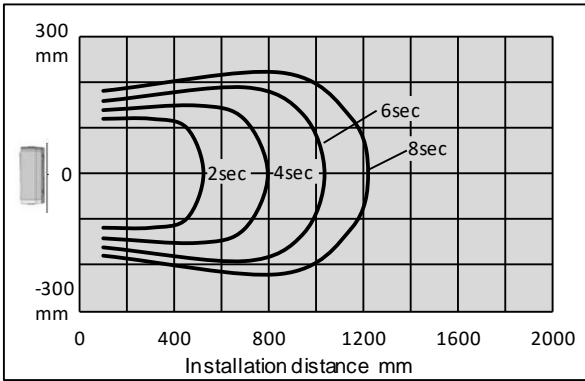

IZF31

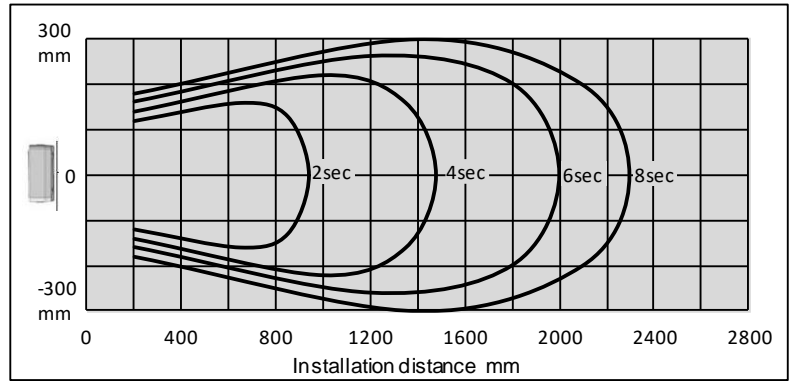

3) Static neutralization area (Air flow setting: 1, Discharge time from 1000 V to 100 V)

IZF21

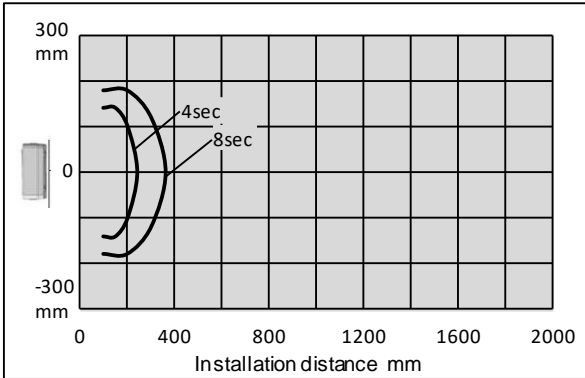

IZF31

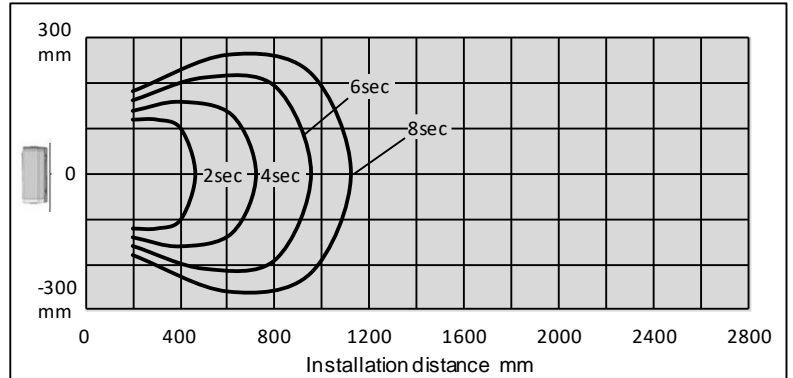

5-2. Performance when using louver

1) Static neutralization area (Angle setting: 1, Air flow setting: 10, Discharge time from 1000 V to 100 V)

IZ21-W

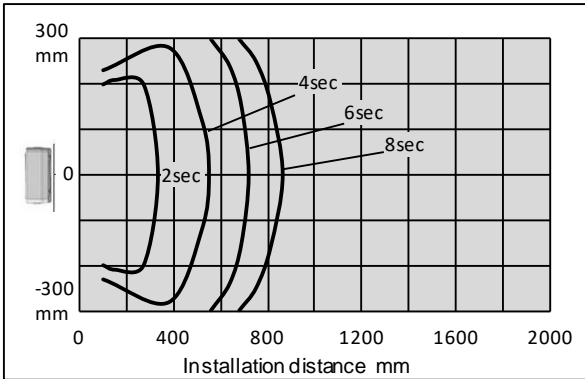

IZF31-W

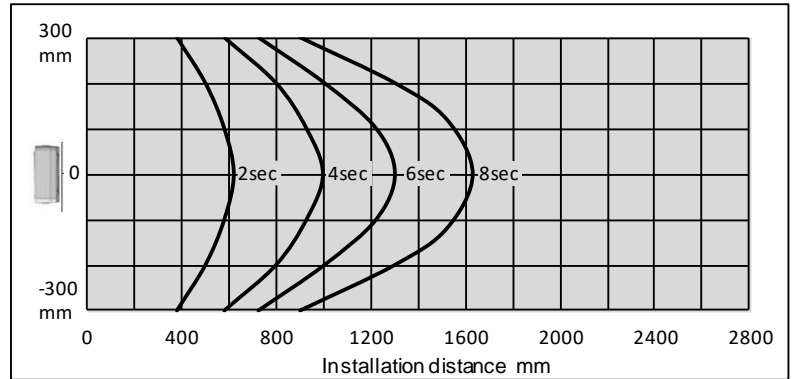

2) Static neutralization area (Angle setting: 5, Air flow setting: 10, Discharge time from 1000 V to 100 V)

IZF21-W

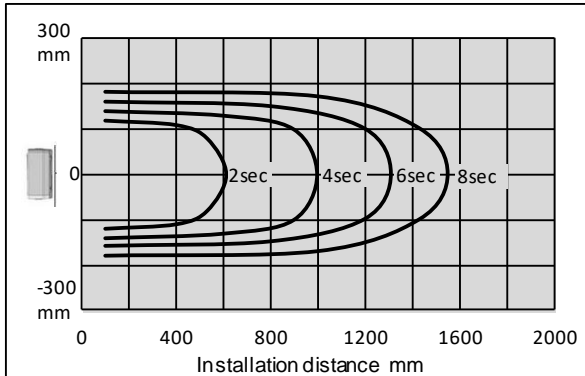

IZF31-W

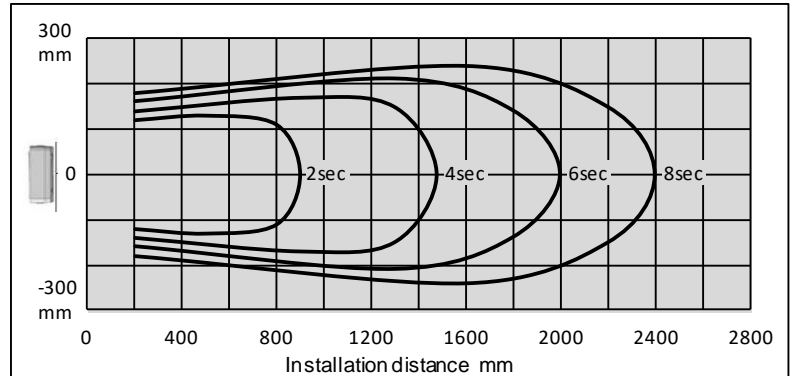

## 6. Dimensions

### IZF21-□-□□□□

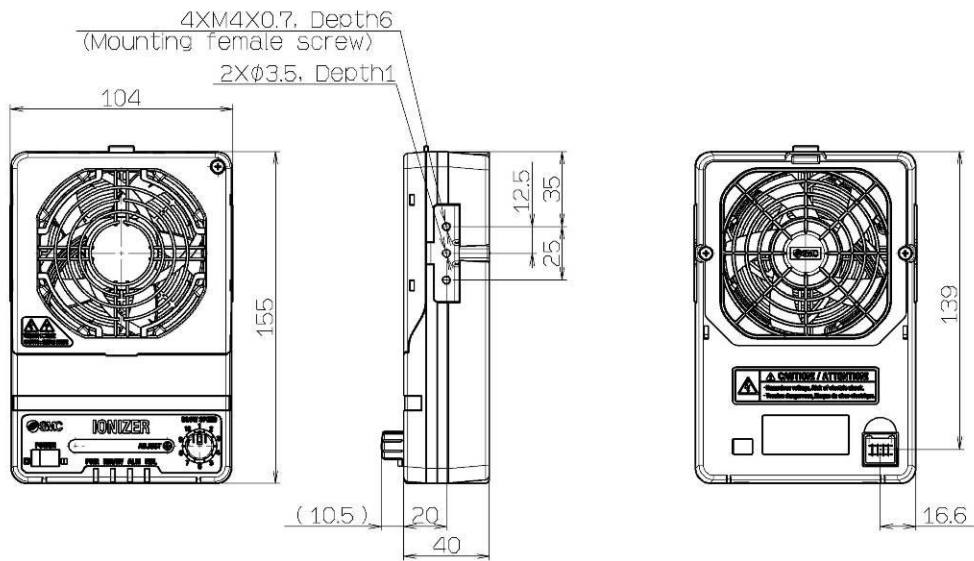

### IZF21-□-□B□□ (with Bracket)

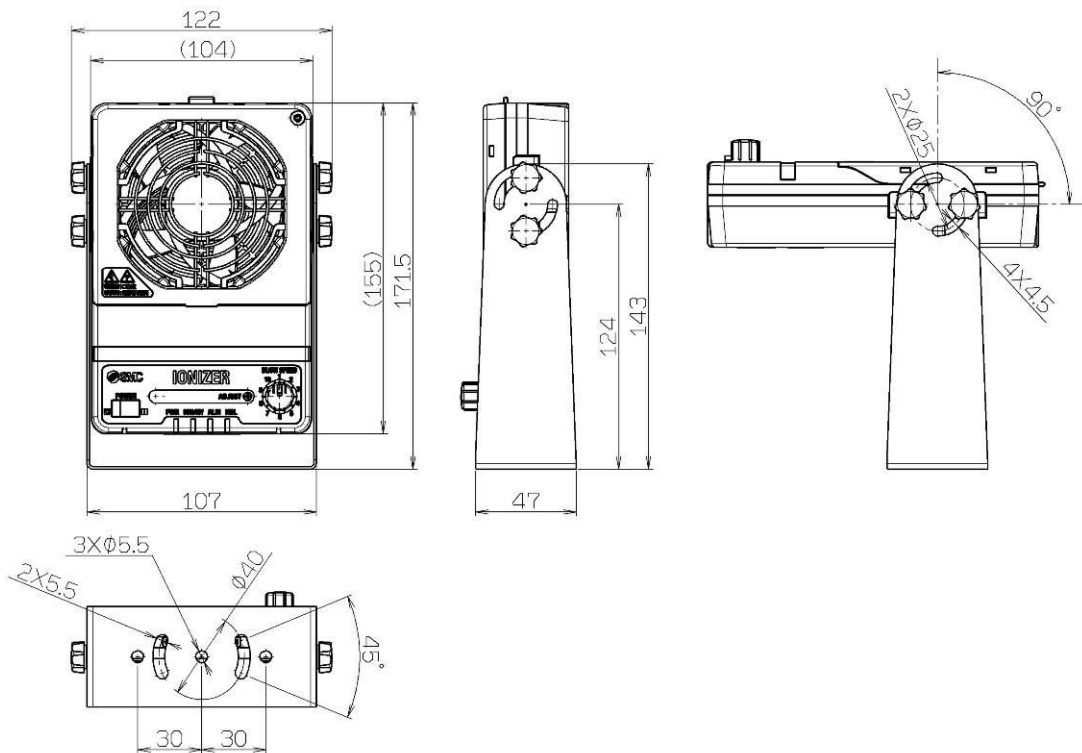





IZF21-□-□□S□ (with Automatic cleaning unit)

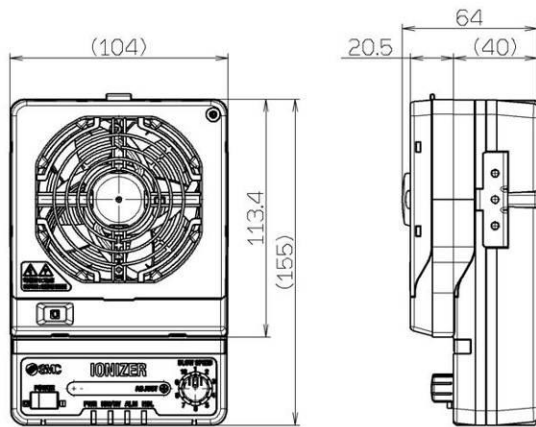

IZF31-□-□□S□ (with Automatic cleaning unit)

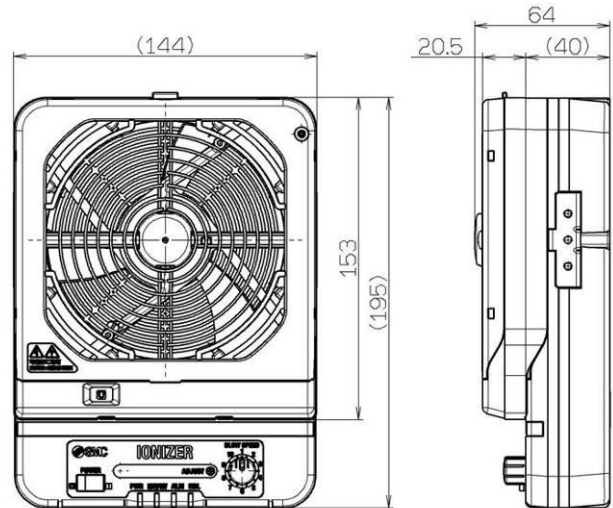

IZF21-□-□□W□ (with Louver)

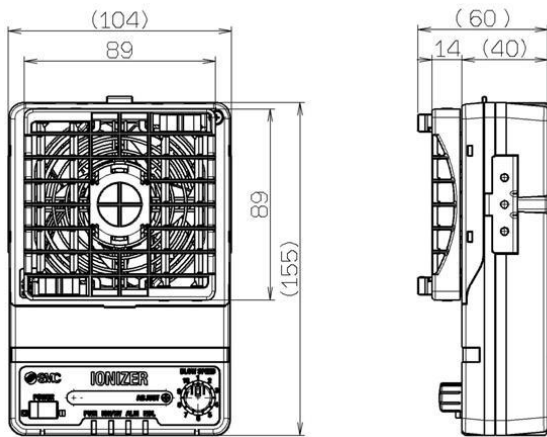

IZF31-□-□□W□ (with Louver)

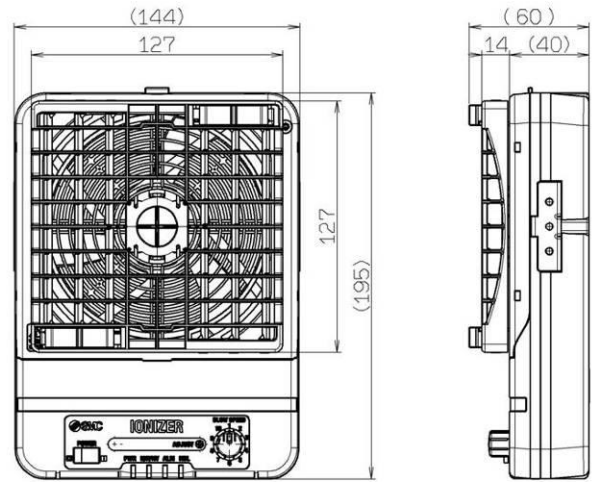

IZF21-□-□□□U (with Filter)

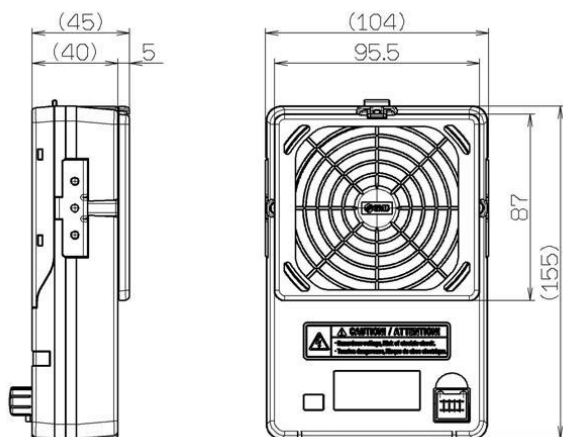

IZF31-□-□□□U (with Filter)

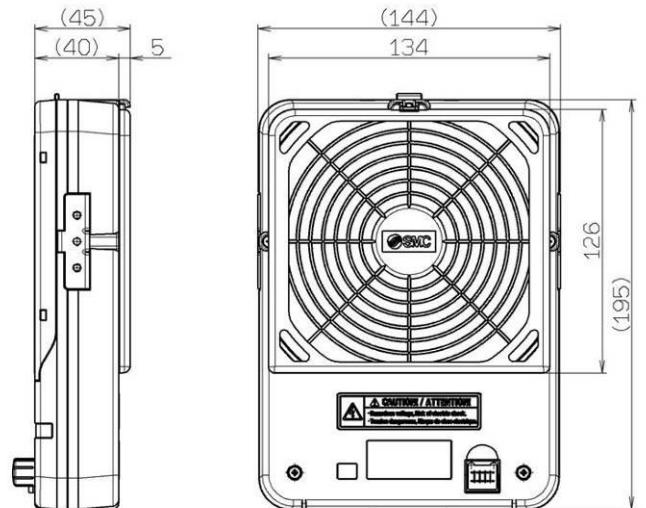



Power supply cable

**IZS41-CP**

Product No.	L
IZS41-CP	3000 <sup>+60</sup> <sub>0</sub>
IZS41-CPZ	9850 <sup>+100</sup> <sub>0</sub>

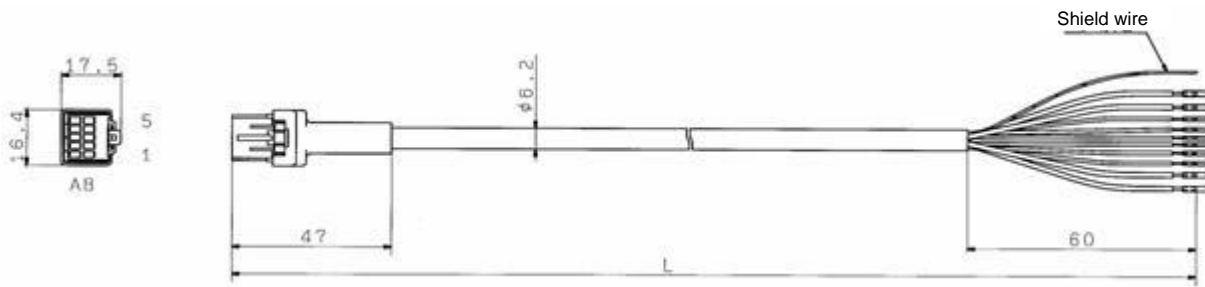

**AC adapter**

IZF21-CG1 (with AC cord)

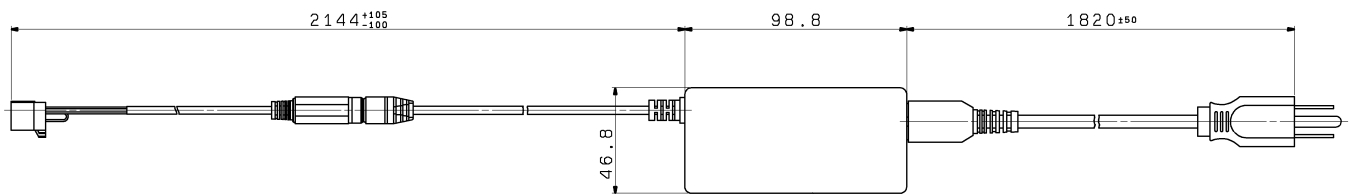

IZF21-CG2 (without AC cord)

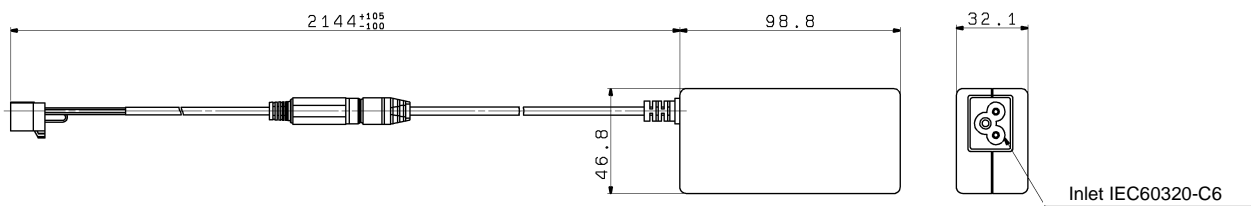

## 7. Specifications

Model		IZF21 (NPN)	IZF21-P (PNP)	IZF31 (NPN)	IZF31-P (PNP)
Air flow		1.8 m <sup>3</sup> /min		4.4 m <sup>3</sup> /min	
Applied voltage		+/-5kV			
Ion generating method		Corona discharging method			
Voltage application		DC			
Offset voltage (ion balance) <small>Note)</small>		+/-5 V			
Power supply voltage		24 VDC +/-10 (%)			
Current consumption		0.9 A or less		1.3 A or less	
Input signal	Ionizer stop signal	Connect with 0V Voltage range: 5 VDC or less Current consumption: 5 mA or less	Connect with +24 V Voltage range: 19 VDC to power supply voltage Current consumption: 5 mA or less	Connect with 0V Voltage range: 5 VDC or less Current consumption: 5 mA or less	Connect with +24V Voltage range: 19 VDC to power supply voltage Current consumption: 5 mA or less
	Cleaning signal				
Output signal	Error signal	Maximum load current: 100 mA Residual voltage: 1 V or less (Load current: 100 mA) Maximum applied voltage: 26.4 VDC	Maximum load current: 100 mA Residual voltage: 1 V or less (Load current: 100 mA)	Maximum load current: 100 mA Residual voltage: 1 V or less (Load current: 100 mA) Maximum applied voltage: 26.4 VDC	Maximum load current: 100 mA Residual voltage: 1 V or less (Load current: 100 mA)
	Maintenance signal				
Ambient temperature		Operating: 0 to 50°C, Stored: -10 to 60°C			
Ambient humidity		Operating, Stored: 35 to 80%RH (no condensation)			
Material		Case: ABS/Stainless steel, Emitter: Tungsten			
Impact resistance		100 m/s <sup>2</sup>			
Weight	Body	430g		605g	
	Bracket	146g		220g	
	Automatic cleaning unit	96g		127g	
	Louver	33g		58g	
	Filter	15g		26g	
Applicable standard /directive		CE (EMC directive 2014/30/EC)			

Note) Based on ANSI/ESD, STM3.1-2006 standard

### AC adapter (IZF21-CG1 / IZF21-CG2)

Input voltage	100 to 240 VAC, 50/60Hz
Output voltage	24 VDC
Output current	1.9A max
Ambient temperature	Operating: 0 to 40°C, Stored: -20 to 65°C
Ambient humidity	Operating, Stored: 5 to 95%RH (no condensation)
Weight	375g (including AC cord connector)
Applicable standard /directive	CE, cUL



## 8. Troubleshooting

Error	No.	Details	Possible causes	Investigation method and possible causes	Countermeasures
Product does not operate	1	No power ("PWR" LED is OFF.)	Power supply incorrectly wired	Check whether both brown wires are connected to 24 VDC and both blue wires are connected to 0V.	Ensure all connections are in accordance with [3-2. Wiring].
	2	Red "PWR" LED is ON.	Power supply voltage is out of range	Check the power supply input is within the range of 24 VDC +/-10%.	Ensure the power supply is in the range of 24 VDC +/- 10%. 1) If dust or dirt is found on the emitter, clean the emitter referring to [4-4. Emitter Dirt Detection and Cleaning].
	3	Red "ION" / HV" LED is ON.	Abnormal high voltage discharge	1) Check the emitter for contamination. 2) Check whether there is arcing between the ionizer and workpiece to be neutralized. 3) Check whether the ionizer is used in an environment subject to condensation or moisture.	2) If there is arcing between the workpiece to be neutralized and the ionizer, increase the distance between them until arcing no longer occurs. 3) The ionizer must not be used in environments subject to condensation or moisture.
	4	Red "ALM" LED is ON.	Foreign matter clogging with the fan motor	Check if there is clogging with foreign matter with the fan motor.	If foreign matter is clogged with the fan motor, remove the emitter cartridge to remove the foreign matter. Refer to "4-5. Replacement of Emitter Cartridge" for the removal of the emitter cartridges.
	5	Red LED of PWR, ION/HV, ALM, and ND.L flash.	CPU malfunction caused by noise	1) Check if there is any high current equipment installed near the ionizer 2) Check if the power supply cable is routed together with any high power cable.	1) If any high current equipment is nearby, either move it away or consider an alternative location for the ionizer. 2) Route the ionizer wiring separately to high power cables. 3) Install a filter to the ionizer power supply.
	6	Red "ND.L" LED is ON.	Emitter cartridge not mounted Emitter Cartridge connection failure	1) Check if the emitter cartridge is mounted in the correct position. 2) Check if the contact failure occurred to the terminal connecting the body and the emitter cartridge due to foreign matter.	1) Mount the emitter cartridge, referring to section [4-5. Replacement of Emitter Cartridge]. 2) Check the terminal of the body and emitter cartridge, referring to section [4-5. Replacement of Emitter Cartridge].
	7	Red LED of ALM is ON, and red LED of ND.L flashes.	Foreign matter clogging with the cleaning arm Malfunction of the origin sensor	1) Check if foreign matter interferes with the rotation of the cleaning arm. Check if a magnetic field is present to cause a malfunction with the origin sensor.	1) Remove foreign matter. 2) If a magnetic field is present, remove the magnetic field or change the installation place of the ionizer.
	8	No output signal	Output circuit wired incorrectly	Check the output specifications (NPN/PNP) and wiring of yellow and purple wires.	Ensure all connections are in accordance with [3-2. Wiring].
	9	Abnormal signal	Output circuit wired incorrectly (over current)	Check the output specifications (NPN/PNP) and wiring of yellow and purple wires.	Ensure all connections are in accordance with [3-2. Wiring].
Abnormal Input	10	Unable to input a signal	Input circuit wired incorrectly	Check the input specifications (NPN/PNP) and wiring of the light green and gray wires.	Ensure all connections are in accordance with [3-2. Wiring].
	11	Poor ion balance (offset voltage)	Adjustment failure of offset voltage (ion balance)	Check the offset voltage (ion balance) with an instrument such as a charged plate monitor.	Adjust the offset voltage (ion balance) with the trimmer labeled "ADJUST" on the front panel.
No/poor neutralizing performance	12	An emitter surface is contaminated	Reduction of ion generation due to the dust or dirt on the emitter	Check the emitter for contamination.	1) If dust or dirt is found on the emitter, clean the emitter referring to [4-4. Emitter Dirt Detection and Cleaning].
	13	Emitter is bent, chipped or worn	Reduction of ion generation due to bending, chipping or wear of the emitter	Examine the emitter tip with a magnifier.	Replace the emitter cartridge.
	14	Green "ND.L" LED is ON.	1) Dust or dirt on the emitter 2) Wearing or breakage of the emitter.	Examine the emitter tip with a magnifier.	1) Refer to [4-4. Emitter Dirt Detection and Cleaning]. 2) Replace the emitter cartridge.
	15	"ION" / HV" LED is OFF	Ionizer stop signal is being input	Check whether the discharge stop signal (light green wire) is being input.	When performing neutralization, do not input the ionizer stop signal.
	16	Ionized air is not reaching the workpiece to be neutralized	1) Inadequate air flow of the ionizer 2) Interference with airflow	1) Check that the air flow rate is sufficient. 2) Check if an external airflow could interfere with the flow of ionized air from the ionizer.	1) If the air flow is not enough, adjust the air flow or place the ionizer closer to the workpiece. 2) If an external airflow is having an effect, consider shutting off the air flow or otherwise changing the installation so that ionized air is not interfered with.
	17	There are obstacles/obstructions between the workpiece to be neutralized and the ionizer	Ionized air blocked or absorbed by obstacles	Check that there are obstacles which could absorb ions on the path used for supplying ionized air to the workpiece to be neutralized.	Objects between the ionizer and workpiece to be neutralized will be blocked off or absorb the ionized air. Ensure there are no objects between, or near to, the ionizer and workpiece to be neutralized.
	18	Two or more ionizers are installed close to each other	Interference with ionized air	Check if ionized air from nearby ionizers is interfering with that of the main ionizer, by starting and stopping the nearby ionizers and seeing if the performance of the main ionizer is affected.	If ionizers are installed close together, they may interfere with each other, and cause a decrease in performance.
	19	No F.G. connection	Incorrect voltage reference	Check whether F.G. (green wire) is connected.	The ionizer neutralizes static electricity relative to ground, ensure the green wire always has a ground connection of less than 100Ω.

Revision history

Revision A (March.27.2024)

The Safety Instructions. (p3, p4)

The words deleted. (Consult SMC beforehand when using this product for other intentions. (See Warning No. 4 on page 3) (p5)

The back cover. (p36)

Revision B (December.3.2024)

Changed rotary switch color from red to white. (p18)

Reword. (the static neutralization time will be long.→the static neutralization time will be longer than without filter.) (p27)

## SMC Corporation

Tel: + 81 3 5207 8249 Fax: +81 3 5298 5362

URL <https://www.smcworld.com>

---

Note: Specifications are subject to change without prior notice and any obligation on the part of the manufacturer.  
© SMC Corporation All Rights Reserved