



# Operation Manual

## PRODUCT NAME

Fieldbus system  
PROFINET compatible SI Unit

## MODEL / Series / Product Number

*EX600-SPN3 / SPN4*  
*EX600-ED#*

**SMC Corporation**

## Table of Contents

Safety Instructions	2
System Outline	8
Definition and terminology	9
Assembly	10
Mounting and Installation	12
<b>SI Unit</b>	
Model Indication and How to Order	15
Summary of Product parts	15
Mounting and Installation	16
LED Display	17
Specification	19
Specifications	19
Dimensions	20
<b>End Plate</b>	
Model Indication and How to Order	21
Summary of Product parts	22
Mounting and Installation	24
Wiring	24
Specification	26
Specifications	26
Dimensions	27
Maintenance	33
Troubleshooting	35
Parameter Setting	46
I/O Map	66
Detail of I/O map of the IO-Link master unit	68
Diagnosis	69
Diagnosis of IO-Link master unit data	72
Hardware Configuration	73
Setting of Fast startup (FSU)	81
Web Server	83
Accessories	91



# Safety Instructions

These safety instructions are intended to prevent hazardous situations and/or equipment damage. These instructions indicate the level of potential hazard with the labels of “**Caution**,” “**Warning**” or “**Danger**.” They are all important notes for safety and must be followed in addition to International Standards (ISO/IEC)<sup>\*)</sup>, and other safety regulations.

\*1) ISO 4414: Pneumatic fluid power - General rules and safety requirements for systems and their components  
ISO 4413: Hydraulic fluid power - General rules and safety requirements for systems and their components  
IEC 60204-1: Safety of machinery - Electrical equipment of machines - Part 1: General requirements  
ISO 10218-1: Robots and robotic devices - Safety requirements for industrial robots - Part 1: Robots  
etc.



## **Danger**

**Danger** indicates a hazard with a high level of risk which, if not avoided, will result in death or serious injury.



## **Warning**

**Warning** indicates a hazard with a medium level of risk which, if not avoided, could result in death or serious injury.



## **Caution**

**Caution** indicates a hazard with a low level of risk which, if not avoided, could result in minor or moderate injury.



## **Warning**

### **1. The compatibility of the product is the responsibility of the person who designs the equipment or decides its specifications.**

Since the product specified here is used under various operating conditions, its compatibility with specific equipment must be decided by the person who designs the equipment or decides its specifications based on necessary analysis and test results. The expected performance and safety assurance of the equipment will be the responsibility of the person who has determined its compatibility with the product. This person should also continuously review all specifications of the product referring to its latest catalog information, with a view to giving due consideration to any possibility of equipment failure when configuring the equipment.

### **2. Only personnel with appropriate training should operate machinery and equipment.**

The product specified here may become unsafe if handled incorrectly. The assembly, operation and maintenance of machines or equipment including our products must be performed by an operator who is appropriately trained and experienced.

### **3. Do not service or attempt to remove product and machinery/equipment until safety is confirmed.**

1. The inspection and maintenance of machinery/equipment should only be performed after measures to prevent falling or runaway of the driven objects have been confirmed.
2. When the product is to be removed, confirm that the safety measures as mentioned above are implemented and the power from any appropriate source is cut, and read and understand the specific product precautions of all relevant products carefully.
3. Before machinery/equipment is restarted, take measures to prevent unexpected operation and malfunction.

### **4. Our products cannot be used beyond their specifications. Our products are not developed, designed, and manufactured to be used under the following conditions or environments. Use under such conditions or environments is not covered.**

1. Conditions and environments outside of the given specifications, or use outdoors or in a place exposed to direct sunlight.
2. Use for nuclear power, railways, aviation, space equipment, ships, vehicles, military application, equipment affecting human life, body, and property, fuel equipment, entertainment equipment, emergency shut-off circuits, press clutches, brake circuits, safety equipment, etc., and use for applications that do not conform to standard specifications such as catalogs and operation manuals.
3. Use for interlock circuits, except for use with double interlock such as installing a mechanical protection function in case of failure. Please periodically inspect the product to confirm that the product is operating properly.



# Safety Instructions

## Caution

**We develop, design, and manufacture our products to be used for automatic control equipment, and provide them for peaceful use in manufacturing industries.**

**Use in non-manufacturing industries is not covered.**

Products we manufacture and sell cannot be used for the purpose of transactions or certification specified in the Measurement Act.

The new Measurement Act prohibits use of any unit other than SI units in Japan.

## Limited warranty and Disclaimer/Compliance Requirements

The product used is subject to the following “Limited warranty and Disclaimer” and “Compliance Requirements”.

Read and accept them before using the product.

### Limited warranty and Disclaimer

1. The warranty period of the product is 1 year in service or 1.5 years after the product is delivered, whichever is first.\*2)

Also, the product may have specified durability, running distance or replacement parts. Please consult your nearest sales branch.

2. For any failure or damage reported within the warranty period which is clearly our responsibility, a replacement product or necessary parts will be provided.

This limited warranty applies only to our product independently, and not to any other damage incurred due to the failure of the product.

3. Prior to using SMC products, please read and understand the warranty terms and disclaimers noted in the specified catalog for the particular products.

**\*2) Vacuum pads are excluded from this 1 year warranty.**

A vacuum pad is a consumable part, so it is warranted for a year after it is delivered.

Also, even within the warranty period, the wear of a product due to the use of the vacuum pad or failure due to the deterioration of rubber material are not covered by the limited warranty

### Compliance Requirements

1. The use of SMC products with production equipment for the manufacture of weapons of mass destruction (WMD) or any other weapon is strictly prohibited.

2. The exports of SMC products or technology from one country to another are governed by the relevant security laws and regulations of the countries involved in the transaction. Prior to the shipment of a SMC product to another country, assure that all local rules governing that export are known and followed.

## Operator

- ◆ This operation manual is intended for those who have knowledge of machinery using pneumatic equipment, and have sufficient knowledge of assembly, operation and maintenance of such equipment. Only those persons are allowed to perform assembly, operation and maintenance.
- ◆ Read and understand this operation manual carefully before assembling, operating or providing maintenance to the product.

### ■ Safety Instructions

#### **Warning**

- Do not disassemble, modify (including changing the printed circuit board) or repair.  
An injury or failure can result.
- Do not operate or set with wet hands.  
This may lead to an electric shock.
- Do not operate the product outside of the specifications.  
Do not use for flammable or harmful fluids.  
Fire, malfunction, or damage to the product can result.  
Verify the specifications before use.
- Do not operate in an atmosphere containing flammable or explosive gases.  
Fire or an explosion can result.  
This product is not designed to be explosion proof.
- If using the product in an interlocking circuit:
  - Provide a double interlocking system, for example a mechanical system.
  - Check the product regularly for proper operation.Otherwise malfunction can result, causing an accident.
- The following instructions must be followed during maintenance:
  - Turn off the power supply.
  - Stop the air supply, exhaust the residual pressure and verify that the air is released before performing maintenance.Otherwise an injury can result.

## **Caution**

- When handling the unit or assembling/replacing units:
  - Do not touch the sharp metal parts of the connector or plug for connecting units.
  - Take care not to hit your hand when disassembling the unit.  
The connecting portions of the unit are firmly joined with seals.
  - When joining units, take care not to get fingers caught between units.  
An injury can result.
- After maintenance is complete, perform appropriate functional inspections.  
Stop operation if the equipment does not function properly.  
Safety cannot be assured in the case of unexpected malfunction.
- Provide grounding to assure the safety and noise resistance of the Fieldbus system.  
Individual grounding should be provided close to the product with a short cable.

## ■ **NOTE**

- Follow the instructions given below when designing, selecting and handling the product.
  - The instructions on design and selection (installation, wiring, environment, adjustment, operation, maintenance, etc.) described below must also be followed.
    - \*Product specifications
      - The direct current power supply to combine should be UL1310 Class 2 power supply when conformity to UL is necessary.
      - Use the specified voltage.  
Otherwise failure or malfunction can result.
      - Reserve a space for maintenance.  
Allow sufficient space for maintenance when designing the system.
      - Do not remove any nameplates or labels.  
This can lead to incorrect maintenance, or misreading of the operation manual, which could cause damage or malfunction to the product.  
It may also result in non-conformity to safety standards.
      - Beware of inrush current when the power supply is turned on.  
Some connected loads can apply an initial charge current which will activate the over current protection function, causing the unit to malfunction.

## ● Product handling

### \*Installation

- Do not drop, hit or apply excessive shock to the SI unit.  
Otherwise damage to the product can result, causing malfunction.
- Tighten to the specified tightening torque.  
If the tightening torque is exceeded the mounting screws may be broken.  
IP67 protection cannot be guaranteed if the screws are not tightened to the specified torque.
- If a large manifold valve is mounted, lift the unit so that stress is not applied to the connecting part while transporting.  
The stress may cause breakage of the connecting part. The unit may become very heavy depending on the combination. Transportation/installation shall be performed by multiple operators.
- Never mount a product in a location that will be used as a foothold.  
The product may be damaged if excessive force is applied by stepping or climbing onto it.

### \*Wiring

- Avoid repeatedly bending or stretching the cables, or placing heavy load on them.  
Repetitive bending stress or tensile stress can cause breakage of the cable.
- Wire correctly.  
Incorrect wiring can break the product.
- Do not perform wiring while the power is on.  
Otherwise damage to the SI unit and/or input or output device can result, causing malfunction.
- Do not route wires and cables together with power or high voltage cables.  
Otherwise the SI unit and/or input or output device can malfunction due to interference of noise and surge voltage from power and high voltage cables to the signal line.  
Route the wires (piping) of the SI unit and/or input or output device separately from power or high voltage cables.
- Confirm proper insulation of wiring.  
Poor insulation (interference from another circuit, poor insulation between terminals, etc.) can lead to excess voltage or current being applied to the product, causing damage.
- Take appropriate measures against noise, such as using a noise filter, when the Fieldbus system is incorporated into equipment.  
Otherwise noise can cause malfunction.

### \*Environment

- Select the proper type of protection according to the environment of operation.  
IP67 protection is achieved when the following conditions are met.
  - (1) The units are connected properly with fieldbus cable with M12 connector and power cable with M12 (M8) connector.
  - (2) Suitable mounting of each unit and manifold valve.
  - (3) Be sure to fit a waterproof cap on any unused connectors.  
If using in an environment that is exposed to water splashes, please take measures such as using a cover.  
Do not use in an environment where moisture or water vapor are present. Otherwise failure and malfunction can result.
- Do not use in a place where the product could be splashed by oil or chemicals.  
If the product is to be used in an environment containing oils or chemicals such as coolant or cleaning solvent, even for a short time, it may be adversely affected (damage, malfunction etc.).
- Do not use the product in an environment where corrosive gases or fluids could be splashed.  
Otherwise damage to the product and malfunction can result.
- Do not use in an area where surges are generated.  
If there is equipment generating large surge near the unit (magnetic type lifter, high frequency inductive furnace, welding machine, motor, etc.), this can cause deterioration of the internal circuitry element of the unit or result in damage. Take measures against the surge sources, and prevent the lines from coming into close contact.

- When a surge-generating load such as a relay, valve or lamp is driven directly, use a product with a built-in surge absorbing element.  
Direct drive of a load generating surge voltage can damage the unit.
- The product is CE/UKCA marked, but not immune to lightning strikes. Take measures against lightning strikes in the system.
- Prevent foreign matter such as dust or wire debris from getting inside the product.
- Mount the product in a place that is not exposed to vibration or impact.  
Otherwise failure or malfunction can result.
- Do not use the product in an environment that is exposed to temperature cycle.  
Heat cycles other than ordinary changes in temperature can adversely affect the inside of the product.
- Do not expose the product to direct sunlight.  
If using in a location directly exposed to sunlight, shade the product from the sunlight.  
Otherwise failure or malfunction can result.
- Keep within the specified ambient temperature range.  
Otherwise malfunction can result.
- Do not operate close to a heat source, or in a location exposed to radiant heat.  
Otherwise malfunction can result.

\*Adjustment and Operation

- Set the switches by using a sharp-pointed screwdriver etc. When setting the switch, do not touch other unrelated parts.  
This can cause parts damage or malfunction due to a short circuit.
- Perform settings suitable for the operating conditions.  
Incorrect setting can cause operation failure.
- Please refer to the PLC manufacturer's manual etc. for details of programming and addresses.  
For the PLC protocol and programming refer to the relevant manufacturer's documentation.

\*Maintenance

- Turn off the power supply, stop the supplied air, exhaust the residual pressure and verify the release of air before performing maintenance.  
There is a risk of unexpected malfunction.
- Perform regular maintenance and inspections.  
There is a risk of unexpected malfunction.
- After maintenance is complete, perform appropriate functional inspections.  
Stop operation if the equipment does not function properly.  
Otherwise safety is not assured due to an unexpected malfunction or incorrect operation.
- Do not use solvents such as benzene, thinner etc. to clean each unit.  
They could damage the surface of the body and erase the markings on the body.  
Use a soft cloth to remove stains.  
For heavy stains, use a cloth soaked with diluted neutral detergent and fully squeezed, then wipe up the stains again with a dry cloth.



## System Outline

### System configuration

The EX600 range of units can be connected to various types of fieldbus to realize the reduction of input or output device wiring and the distributed control system.

The unit communicates with the fieldbus through the SI unit.

One SI unit can be connected with manifold valves with up to 32 outputs and the input • output • I/O • IO-Link master units with maximum 10 units.

Maximum numbers of connected IO-Link master units is 4.

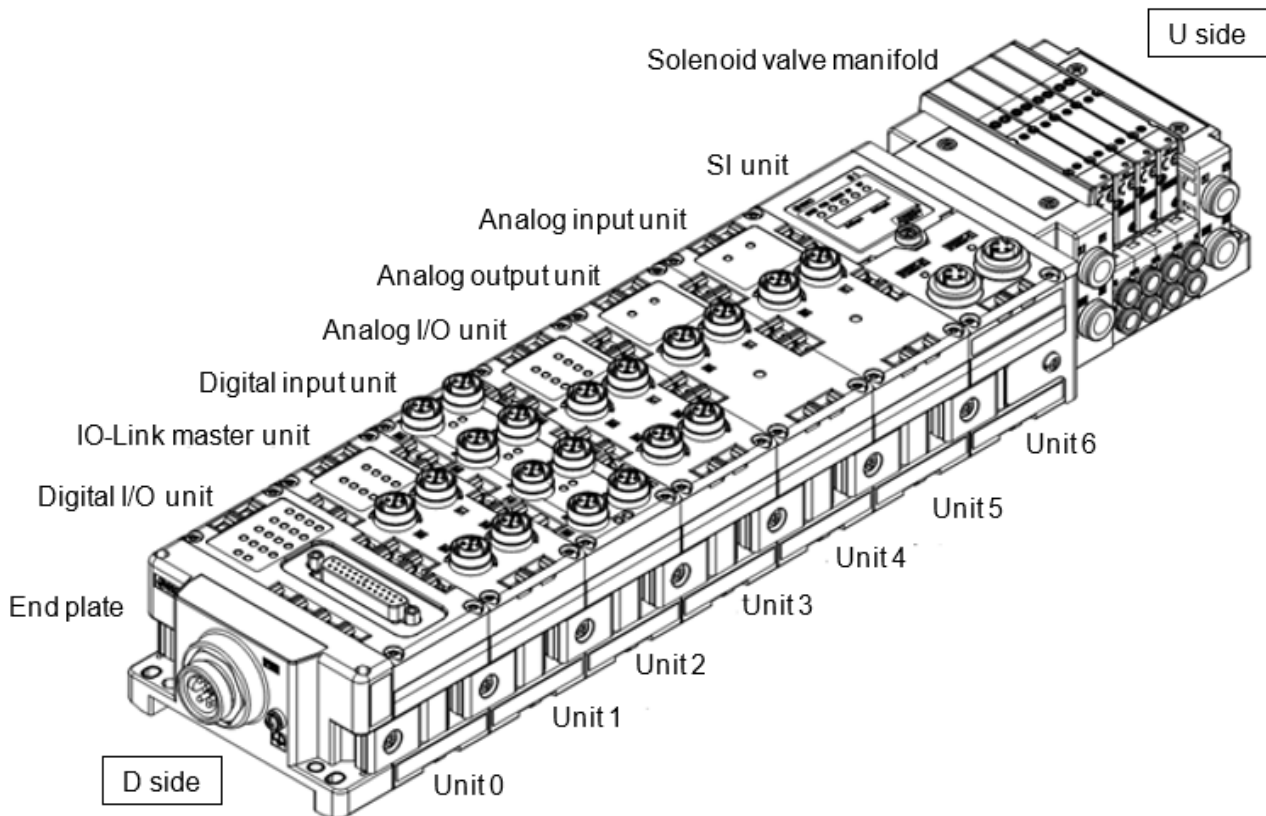

Name	Function
SI unit	Performs fieldbus communication and solenoid valve manifold ON/OFF output.
Digital input unit	For connecting sensors with switch output capability. PNP and NPN types are available.
Digital output unit	For connecting output device such as solenoid valves, lamps, buzzers, etc. PNP and NPN types are available.
Digital I/O unit	This unit has both digital input and output functions. PNP and NPN types are available.
Analogue input unit	For connecting sensors with analogue output capability.
Analogue output unit	This can be connected to the equipment which can read analogue input.
Analogue I/O unit	This unit has both analogue input and output functions.
IO-Link master unit	Compatible with IO-Link devices. There are two port types, class A and class B.
End plate	Connected at EX600 Manifold's D side, incorporating the power supply connection.
Solenoid valve manifold	An assembly of solenoid valves. One connector is used as the electric connection to all connected valves.

## ■ Definition and terminology

	Terminology	Definition
100	100BASE-TX	Standard of LAN transmission line with communication speed of 100 Mbps.
C	Current consumption	The current necessary to operate each unit.
D	DIN rail	A metal rail conforming with DIN (German) standard.
	D Side	The side connected to the end plate when the product is connected to a manifold.
E	Enclosure (IP□□)	Abbreviation of international (ingress) protection. A standard related to the protection from external objects (hands, steel ball, steel wire, dust, water, etc.) applied to the product.
F	FE	Abbreviation of functional earth.
	Fieldbus	The protocol that uses digital communication to exchange signals between field equipment (instruments and actuators) running on site and a PLC.
G	GSDML file	File describes the product master data.
I	IP address	A 32 bit digit sequence which is assigned to identify devices which are connected to the network.
M	MAC address	A unique number inherent to all devices which are connected to EtherNet/IP™.
	Manifold	A form consisting of multiple components. A form made by combining multiple components.
N	NPN input	Takes the sensor output that uses the NPN transistor to the signal output line.
	NPN output	The output type that uses an NPN transistor to operate output device. It is also known as a positive common type since a positive potential is applied to the power supply line.
	Number of inputs	The number of points that can receive information from input device (sensor, switch, etc.).
	Number of outputs	The number of points that can operate output device (solenoid valve, light, motor, etc.).
O	Open circuit detection	A diagnosis function to detect if the input or output device wiring is disconnected.
P	PLC	Abbreviation of programmable logic controller. A digital computer used for automation of electromechanical processes.
	PNP input	Takes the sensor output that uses the PNP transistor to the signal output part.
	PNP output	The output type that uses a PNP transistor to operate output device. It is also known as a negative common type since a negative potential is applied to the power supply line.
S	Short circuit detection	A diagnosis function to detect an over current due to the short circuit of the output and/or power supply positive line with respect to the GND line.
	Short circuit protection	A function to protect the internal circuit from being broken by an over current due to the short circuit of the output and/or power supply positive line with respect to the GND line.
	SI unit	Abbreviation of serial interface unit. A unit connected to a PLC to communicate input and output data.
U	U Side	The side connected to the solenoid valve when the product is connected to a manifold.

## Assembly

### ● Composing the unit as a manifold

\*: If the unit was purchased as a manifold, the work described in this section is not necessary.

- (1) Connect the unit to the end plate.  
The Digital unit, Analogue unit can be connected in any order.  
(Tightening torque: 1.5 to 1.6Nm)

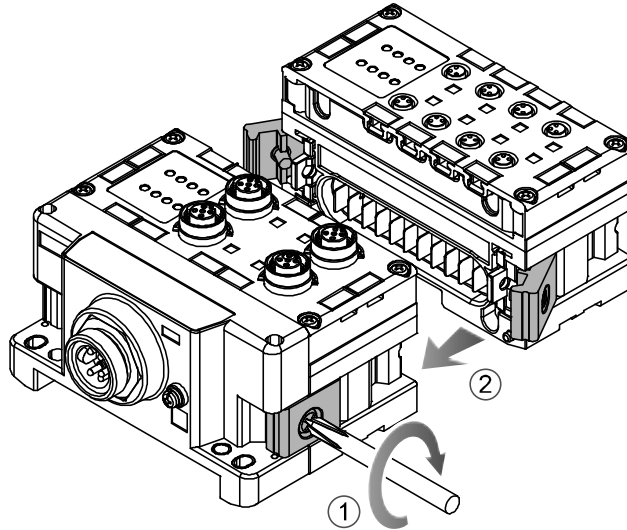

- (2) Add more units.  
Up to 10 units (including the SI unit) can be connected to one manifold.

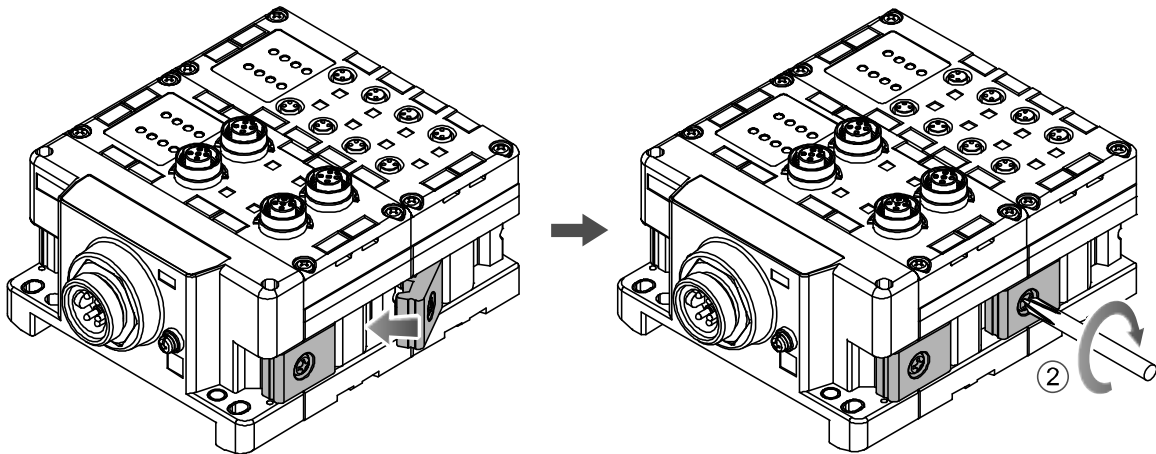

- (3) Connecting the SI unit.  
After connecting the necessary units, connect the SI unit.  
Connecting method is the same as above (1), (2).

(4) Mounting the valve plate.

Mount the valve plate (EX600-ZMV#) to the valve manifold using the valve set screws. (M3 x 8)  
(Tightening torque: 0.6 to 0.7 Nm)

Screw mounting place	
SV	: 2 places
S0700	: 2 places
VQC1000	: 2 places
VQC2000	: 3 places
VQC4000	: 4 places
SY	: 2 places
JSY	: 2 places

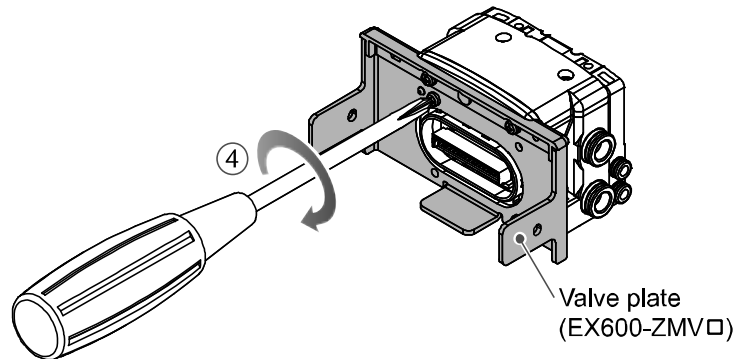

(5) Connect the SI unit and the valve manifold.

Insert the valve plate to the valve plate set groove on the side of SI unit.  
Then, tighten it with the valve plate set screws (M4 x 6) to fix the plate.  
(Tightening torque: 0.7 to 0.8 Nm)

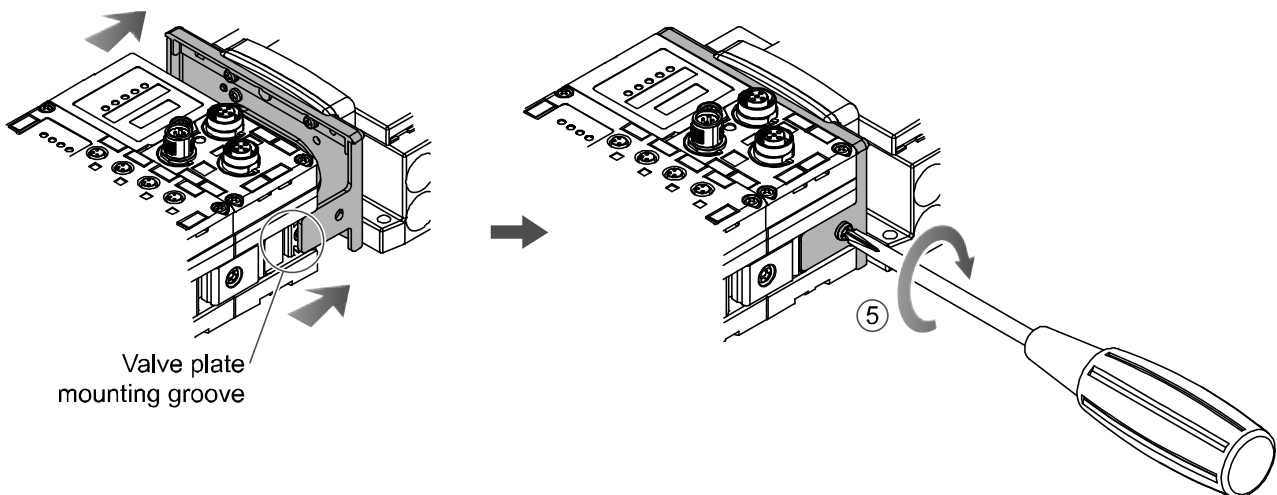

● Precautions for handling

- Please do not connect the unit while the power supply is active. It will cause equipment damage.
- Take care not to drop the nuts of Joint bracket.
- Tighten the screws to the specified torque.  
Insufficient tightening may lead to equipment malfunction, injury or equipment damage.

# Mounting and Installation

## ■ Installation

### • Direct mounting

#### (1) Direct mounting

When joining six or more units, fix the middle part of the complete EX600 unit with an intermediate reinforcing brace (EX600-ZMB1) before mounting using 2-M4 x 5 screws.  
(Tightening torque: 0.7 to 0.8 Nm)

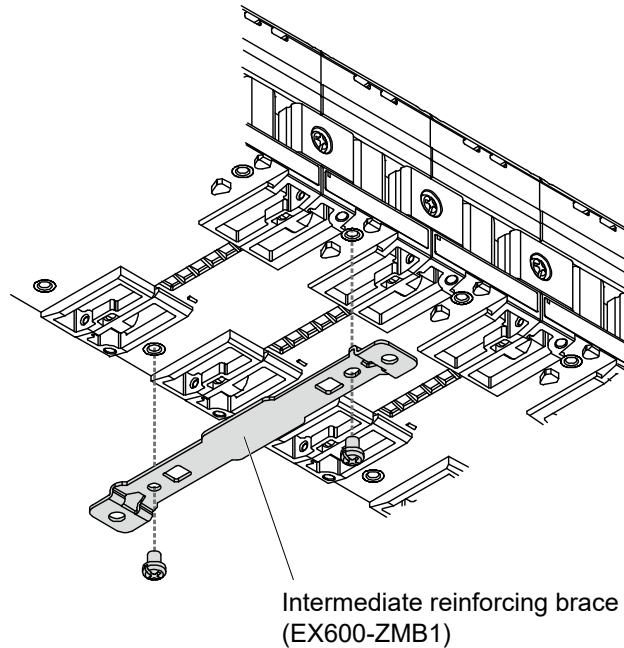

#### (2) Fix and tighten the end plates at one end of the unit. (M4)

(Tightening torque: 0.7 to 0.8 Nm)

Fix the end plate at the valve side while referring to the operation manual of the corresponding valve manifold.

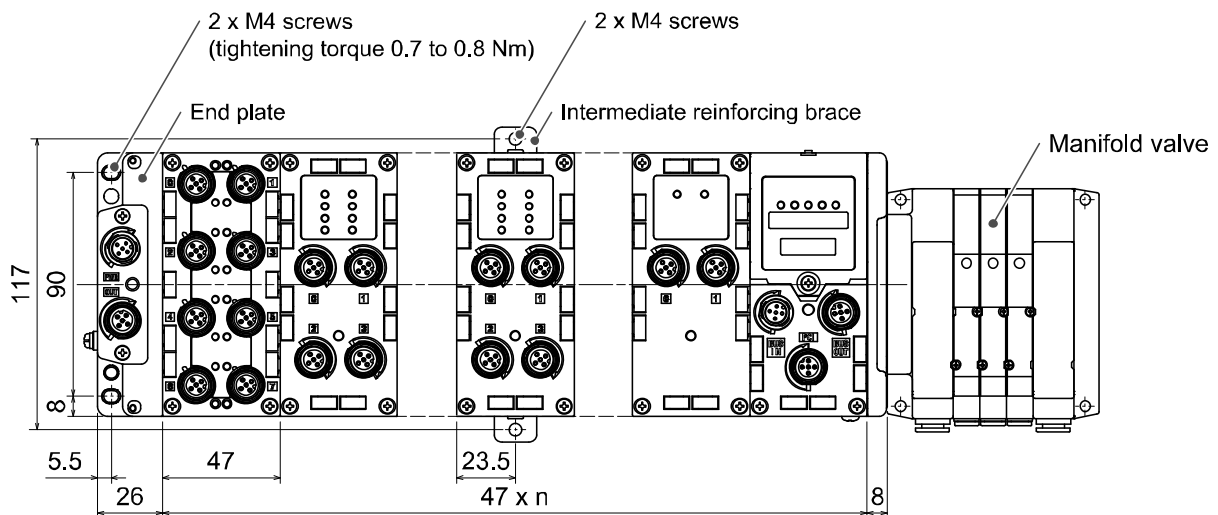

n (Number of connected Units) ≤ 10

### • Precautions for handling

- When joining six or more units, fix the middle part of the complete unit with an intermediate reinforcing brace to prevent incorrect connection between the units due to deflection.

### •DIN rail mounting

(Not available for SY series valves. Refer to the SY catalog.)

- (1) When joining six or more units, fix the middle part of the complete EX600 unit with an intermediate reinforcing brace (EX600-ZMB2) before mounting, using 2-M4 x 6 screws. (Tightening torque: 0.7 to 0.8 Nm)
- (2) Mount the end plate bracket (EX600-ZMA2) to the end plate at the opposite end to the valves, using 2-M4 x 14 screws. (Tightening torque: 0.7 to 0.8 Nm)

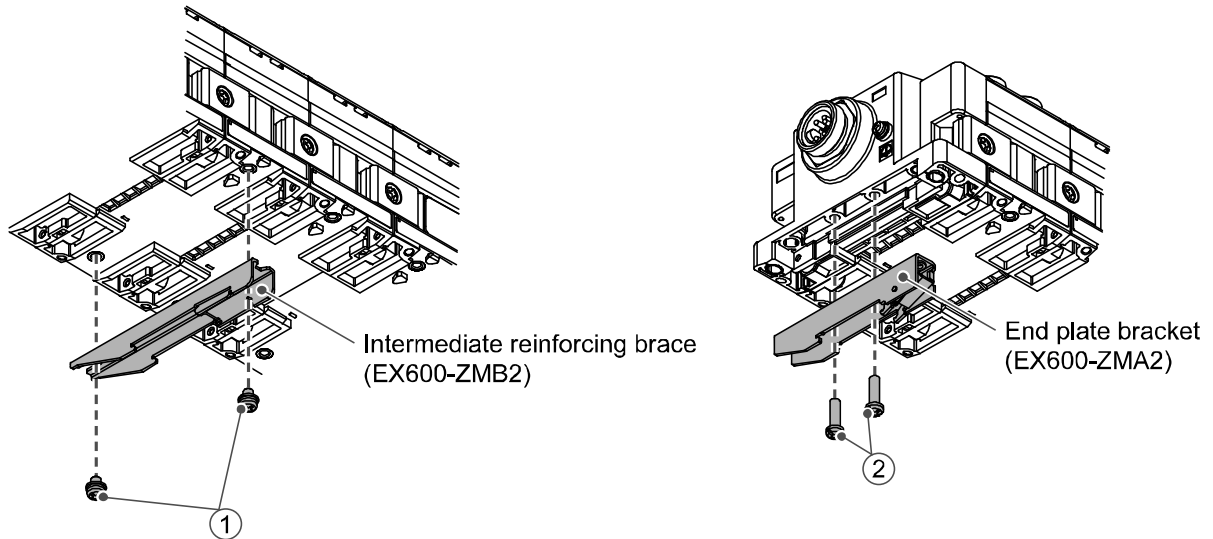

- (3) Hook the DIN rail mounting groove to the DIN rail.
- (4) Press the manifold using its side hooked to the DIN rail as a fulcrum until the manifold is locked.
- (5) Fix the manifold by tightening the DIN rail fixing screws of the EX600-ZMA2. (M4 x 20)  
(Tightening torque: 0.7 to 0.8 Nm)  
The tightening torque at the valve side depends on the valve type.  
Refer to the operation manual of the corresponding valve manifold.

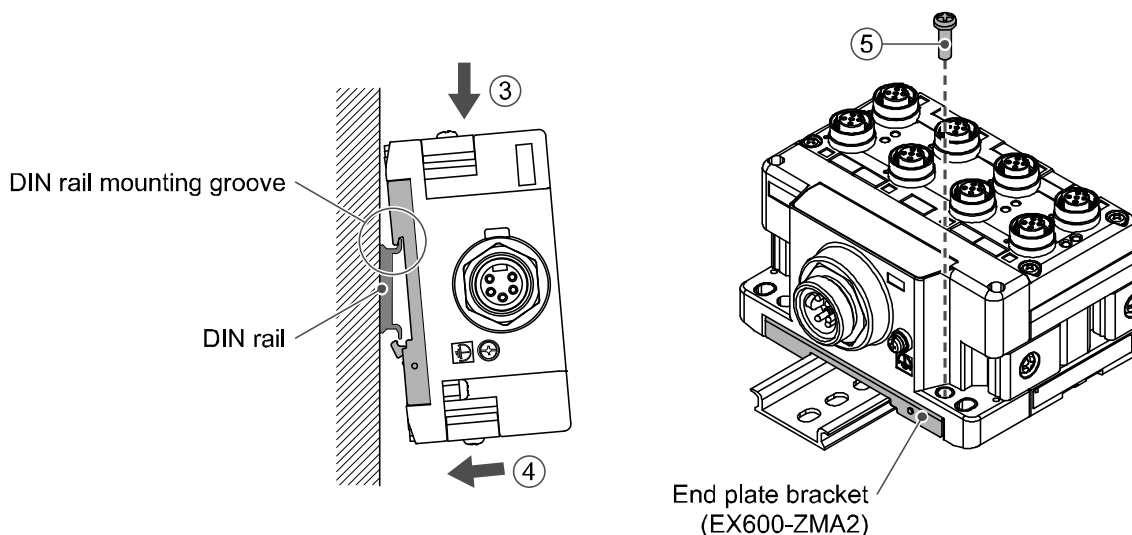

### •Precautions for handling

- When joining six or more units, fix the middle part of the complete unit with an intermediate reinforcing brace to prevent incorrect connection between the units due to deflection.

**•Mounting the marker**

Signal name of the input or output devices and unit address can be written to the marker, and it can be installed to each unit.

Mount the marker (EX600-ZT1) into the marker groove as required.

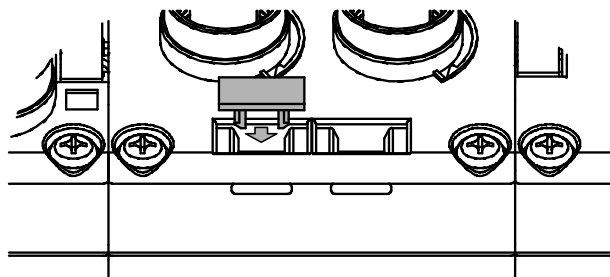

# SI Unit

## Model Indication and How to Order

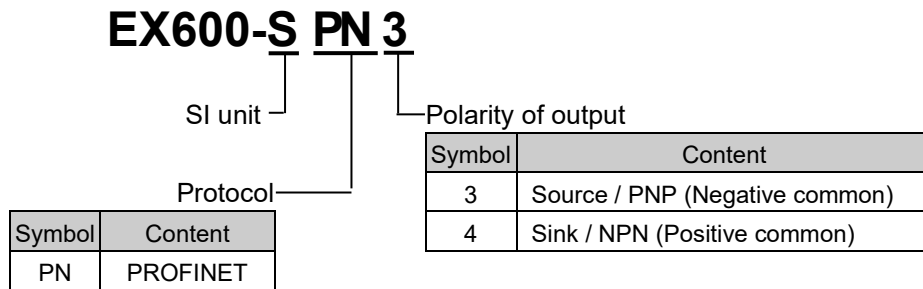

## Summary of Product parts

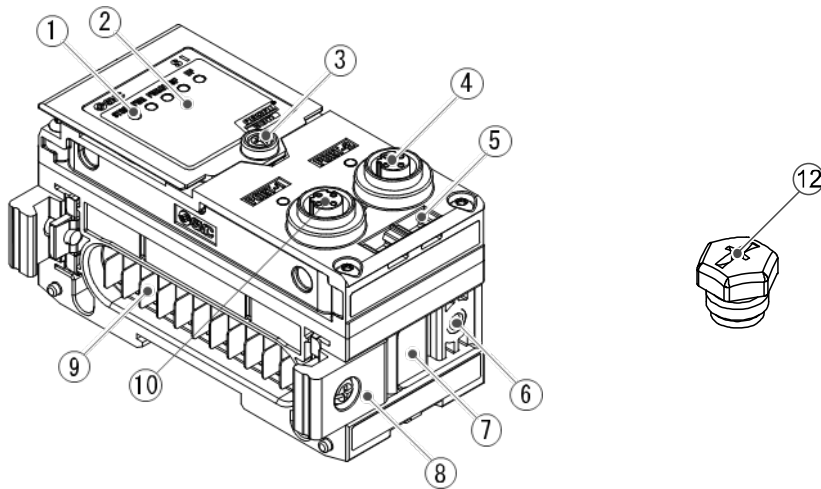

No.	Description	Function
1	Status display LED	Displays the status of the unit.
2	Display cover	The display cover should not be opened.
3	Display cover tightening screw	Do not loosen the screw.
4	Communication connector (PORT 2)	Connects the cable for fieldbus outputs.
5	Marker groove	Groove to mount a marker.
6	Valve plate mounting screw hole	Fixes the valve plate.
7	Valve plate mounting groove	Groove to insert the valve plate into.
8	Joint bracket	Bracket for joining to adjacent units.
9	Unit connector (plug)	Transmits signals and power supplies to adjacent units.
10	Communication connector (PORT 1)	Connects the cable for fieldbus inputs.
12	Seal cap	Mounted on to unused connectors (PORT2).



## Mounting and Installation

### ■Wiring

#### ○Connector pin assignment

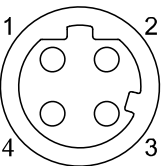
Configuration	Pin No.	Signal name
PORT 1 / PORT 2		
	1	TX+
	2	RX+
	3	TX-
	4	RX-

#### ●Precautions for handling

Be sure to fit a seal cap on any unused connectors. Proper use of the seal cap enables the enclosure to achieve IP67 specification.

## LED Display

LED display shows the power supply and communication status.

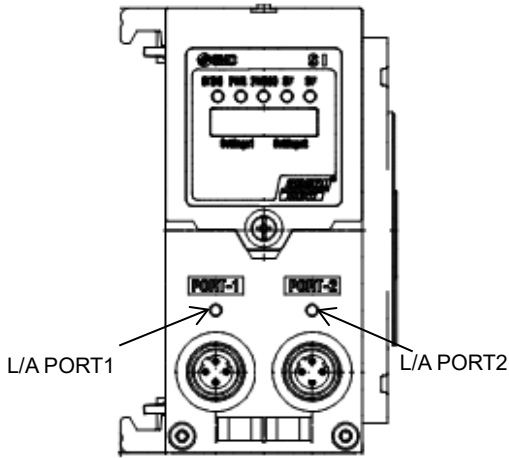

Display	Content
ST(M)	Displays the diagnosis status of the unit.
PWR	Displays the status of the power supply voltage for control and input.
PWR(V)	Displays the status of the power supply voltage for output.
SF	Displays the system status.
BF	Displays the communication status.

Display	Content
L/A PORT1	Displays the communication status of the PORT1 side.
L/A PORT2	Displays the communication status of the PORT2 side.

### •ST(M)

LED display	Content
Green ON	Normal operation.
Green flashing	Diagnostic error of I/O unit is detected.
Red flashing	Either of the following diagnostic error is detected. (When diagnostic parameter is enabled) •Valve ON/OFF counter has exceeded the set value. •Valve is short circuited or disconnected.
Red/green flashing alternately	Detect a communication error between SI unit and I/O unit.
Red ON	SI unit has failed.

### •PWR-LED

LED display	Content
Green ON	The power supply voltage for control and input is properly.
Red ON	The power supply voltage for control and input is below 19VDC. (When diagnostic parameter is enabled)

### •PWR(V)-LED

LED display	Content
OFF	The power supply voltage for output is below 19VDC. (When diagnostic parameter is disabled)
Green ON	The power supply for output is properly.
Red ON	The power supply voltage for output is below 19VDC. (When diagnostic parameter is enabled)

•SF-LED

LED display	Content
OFF	Normal operation
Red ON	Diagnostic error is detected.
Green flashing	Node flashing test.

•BF-LED

LED display	Content
OFF	PROFINET communication is established.
Red flashing	The configuration data of PLC and actual EX600 configuraion is not consistent.
Red ON	Either of the following conditions. <ul style="list-style-type: none"> <li>•Device name setting to PLC and SI unit is not consistent.</li> <li>•The communication cable is not connected.</li> <li>•The PLC or SI unit has broken.</li> </ul>

•L/A PORT1-LED

LED display	Content
OFF	No Link, No Activity (Port1 side)
Green ON	Link, No Activity (Port1 side)
Green flashing	Link, Activity (Port1 side)

•L/A PORT2-LED

LED display	Content
OFF	No Link, No Activity (Port2 side)
Green ON	Link, No Activity (Port2 side)
Green flashing	Link, Activity (Port2 side)

# Specification

## ■ Specifications

Model		EX600-SPN3	EX600-SPN4
Communication	Protocol	PROFINET V2.35	
	Conformance class	Class C (only for IRT switch function)	
	Communication speed	100 Mbps	
	Configuration file	GSDML file	
	Applicable function	Fast start up MRP (Media redundancy protocol) System redundancy s2 Web server	
Electrical	Power supply for control / input	24VDC, 2A	
	Power supply for output	24VDC, 2A	
	Internal current consumption (Power supply for control / input)	120mA or less	
Valve output	Output type	Source / PNP (Negative common)	Sink / NPN (Positive common)
	Number of solenoid valves	32 outputs	
	Connected load and output rating	Solenoid valve with surge voltage suppressor of 24 VDC and 1.0 W or less (manufactured by SMC)	
	Fail safe	HOLD / CLEAR / Force ON	
	Protection	Short circuit protection	
Environment	Operating temperature range	-10 to 50 °C	
	Storage temperature range	-20 to 60 °C	
	Operating humidity range	35 to 85% RH (no dew condition)	
	Vibration resistance	10 to 57 Hz: constant amplitude 0.75 mm p-p 57 to 150 Hz: constant acceleration 49 m/s <sup>2</sup> for 2 hours in each direction X, Y and Z respectively (De-energized)	
	Impact resistance	147 m/s <sup>2</sup> 3 times in each directions of X, Y and Z respectively (De-energized)	
Enclosure	IP67 (manifold assembly) *1		
Standard	CE/UKCA marked, UL (CSA)		
Weight	300 g		

\*1: All unused connectors must have a seal cap fitted.

## ■Dimensions

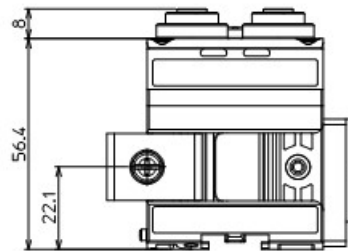
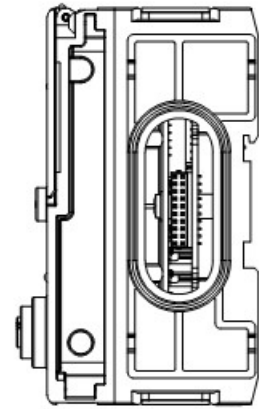
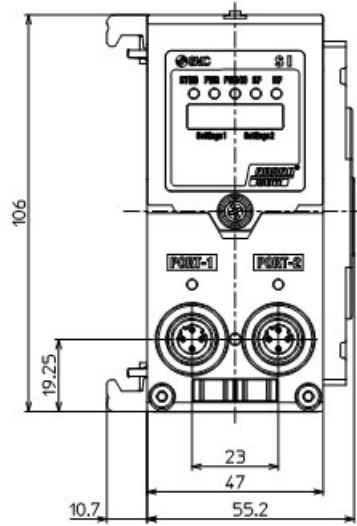
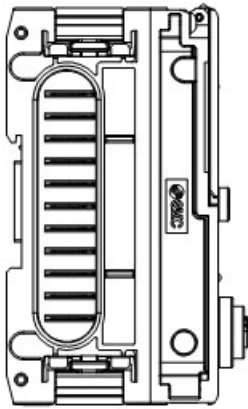

# End plate

## Model Indication and How to Order

**EX600-ED** □ - □

End plate at D side

Mounting method

Connector

Symbol	Connector	Key type	Function
2	M12 (5 pin)	B code	IN
3	7/8 inch (5 pin)	-	IN
4	M12 (4 pin/5 pin)	A code	IN/OUT (PIN layout 1*)
5	M12 (4 pin/5 pin)	A code	IN/OUT (PIN layout 2)

Symbol	Description
Nil	No DIN rail bracket
2	With DIN rail bracket (VQC/SV/S0700 valve)
3	With DIN rail bracket (SY/JSY valve)

\*: Refer to Connector Pin No. (page 24) for details of the PIN layout 1 and 2.

**EX600-EU1** - □

End plate at U side

Mounting method

Symbol	Description
Nil	No DIN rail bracket
2	With DIN rail bracket (EX600-ED#-2)
3	With DIN rail bracket (EX600-ED#-3)

## Summary of Product parts

### •EX600-ED2-□

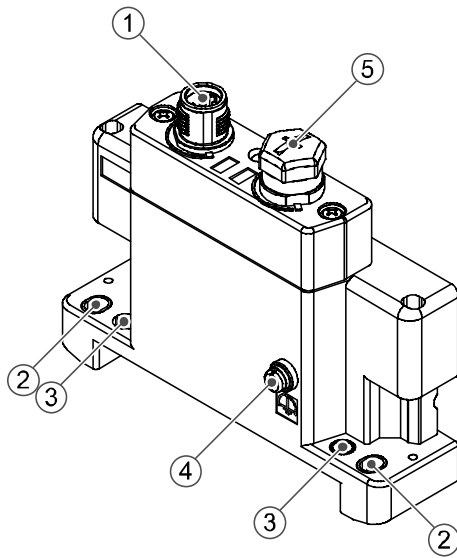

### •EX600-ED3-□

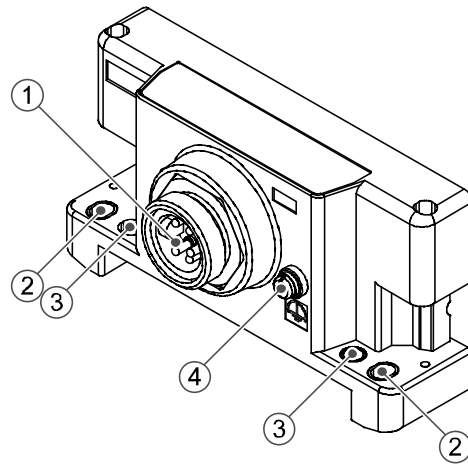

### •EX600-EU1-□

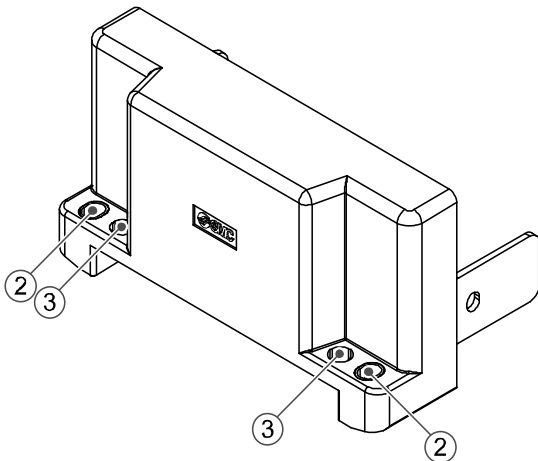

No.	Description	Function
1	Power connector	Connector for power supply to SI unit and I/O unit.
2	Fixing hole for direct mounting	Holes for direct mounting.
3	DIN rail fixing hole	Holes for fix DIN rail mounting.
4	F.E. terminal *	Functional Earth terminal - must be connected directly to system earth (ground).
5	Connector (Not used)	Unused connector. Do not remove seal cap.

\*: Individual grounding should be provided close to the product with a short cable.

•EX600-ED4/ED5-□

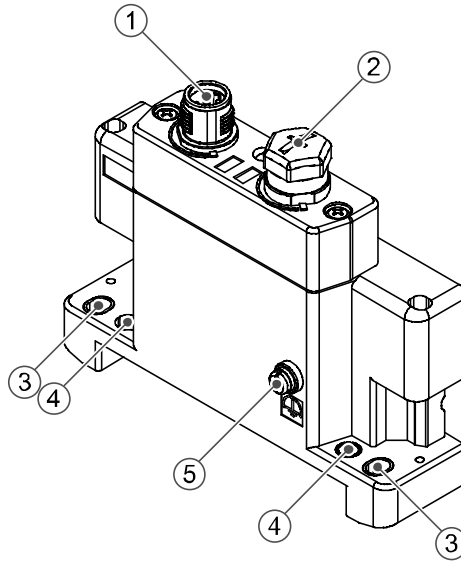

No.	Description	Function
1	Power connector (PWR IN)	Supplies power for each unit and input/output devices.
2	Power connector (PWR OUT)	Provides power to downstream equipment.
3	Fixing hole for direct mounting	Holes used for direct mounting.
4	DIN rail fixing hole	Holes used for fix DIN rail.
5	F.E. terminal *	Functional Earth terminal - must be connected directly to system earth (ground).

\*: Individual grounding should be provided close to the product with a short cable.



# Mounting and Installation

## ■Wiring

### ○Connector pin assignment

#### (1) EX600-ED2-□

PWR IN: M12 5-pin Plug B code

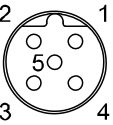
Configuration	Pin No.	Signal name
	1	24 V (Output)
	2	0 V (Output)
	3	24 V (Control and input)
	4	0 V (Control and input)
	5	F.E.

#### (2) EX600-ED3-□

PWR IN: 7/8 inch 5-pin Plug

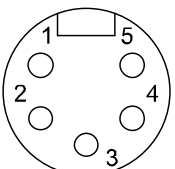
Configuration	Pin No.	Signal name
	1	0 V (Output)
	2	0 V (Control and input)
	3	F.E.
	4	24 V (Control and input)
	5	24 V (Output)

#### (3) EX600-ED4-□

PWR IN: M12 4-pin Plug A code

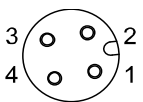
Configuration	Pin No.	Signal name
	1	24 V (Control and input)
	2	24 V (Output)
	3	0 V (Control and input)
	4	0 V (Output)

PWR OUT: M12 5-pin Socket A code

Configuration	Pin No.	Signal name
	1	24 V (Control and input)
	2	24 V (Output)
	3	0 V (Control and input)
	4	0 V (Output)
	5	Not used

#### (4) EX600-ED5-□

PWR IN: M12 4-pin Plug A code

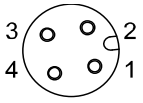
Configuration	Pin No.	Signal name
	1	24 V (Output)
	2	0 V (Output)
	3	24 V (Control and input)
	4	0 V (Control and input)

PWR OUT: M12 5-pin Socket A code

Configuration	Pin No.	Signal name
	1	24 V (Output)
	2	0 V (Output)
	3	24 V (Control and input)
	4	0 V (Control and input)
	5	Not used

○Regarding the 2 types of power supply

The power supply consists of two power supply systems as follows:

- Power supply for control and input: Supplying power for control of each unit's power supply for control and also for device connected to input port of Digital and Analogue unit.
- Power supply for output: Supplying power for equipment connected to output port of Digital and Analogue unit, and also power supply for solenoid valve manifold.

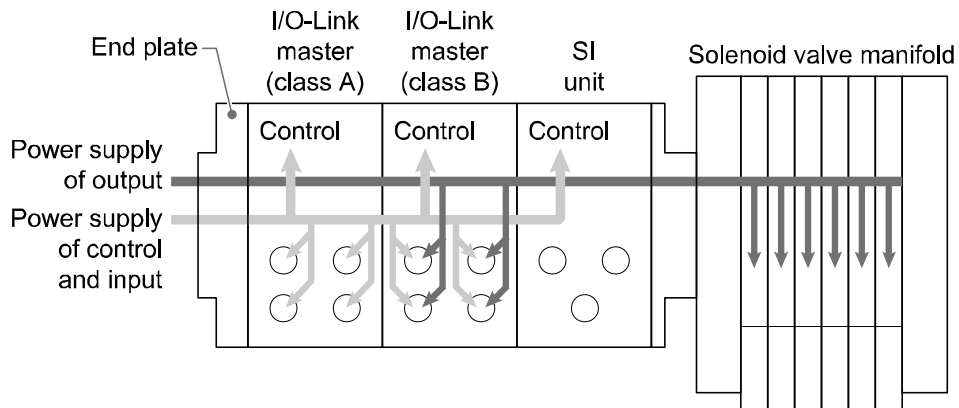
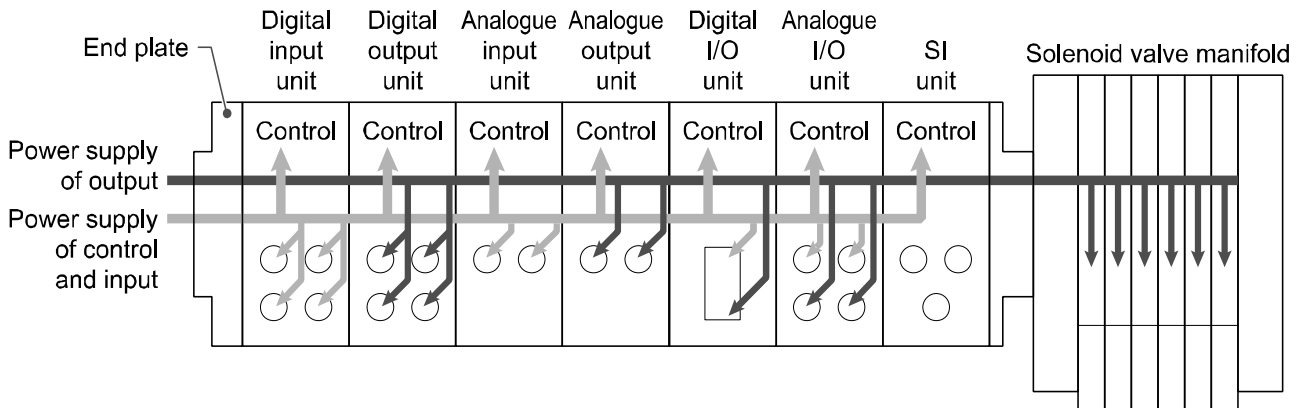

●Precautions for handling

Be sure to fit a seal cap on any unused connectors. Proper use of the seal cap enables the enclosure to achieve IP67 specification.

# Specification

## ■ Specifications

Model			EX600-ED2-□	EX600-ED3-□	EX600-ED4-□	EX600-ED5-□
Power	Power connector	PWR IN	M12 (5 pin) Plug	7/8 inch (5 pin) Plug	M12 (4-pin) Plug	M12 (4-pin) Plug
		PWR OUT	-	-	M12 (5-pin) Socket	M12 (5-pin) Socket
	Power supply (Control and input)		24 VDC ±10%, 2 A	24 VDC ±10%, 8 A	DC24 V ±10%, 4 A	
	Power supply (Output)		24 VDC +10/-5%, 2 A	24 VDC +10/-5%, 8 A	DC24 V +10/-5%, 4 A	
Environment	Enclosure		IP67 (With manifold assembled) *1			
	Operating temperature range		-10 to 50 °C			
	Storage temperature range		-20 to 60 °C			
	Operating humidity range		35 to 85%R.H. (No condensation)			
	Withstand voltage		500 VAC for 1 minute between external terminals and F.E.			
	Insulation resistance		500 VDC, 10 MΩ min. between external terminals and F.E.			
Standard			CE/UKCA marked, UL (CSA)		CE/UKCA marked	
Weight			170 g	175 g	170 g	

\*1: All unused connectors must have a seal cap fitted.

## ■Dimensions

### •EX600-ED2

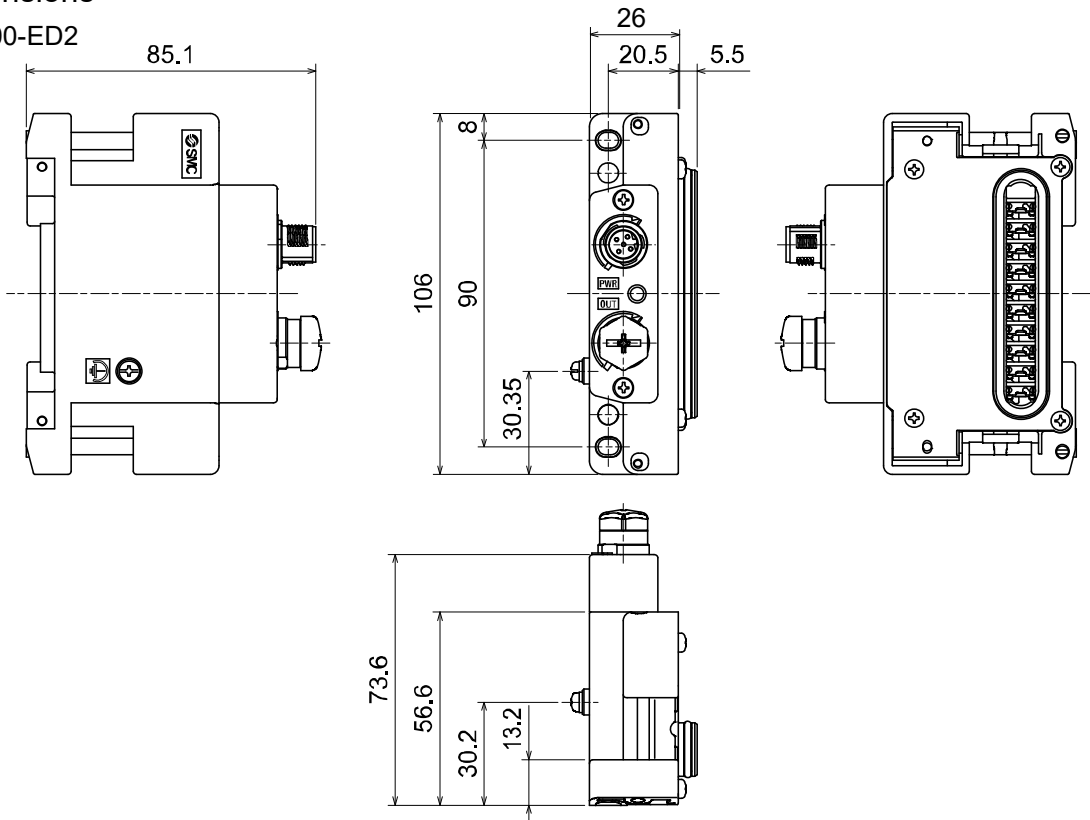

### •EX600-ED2-2

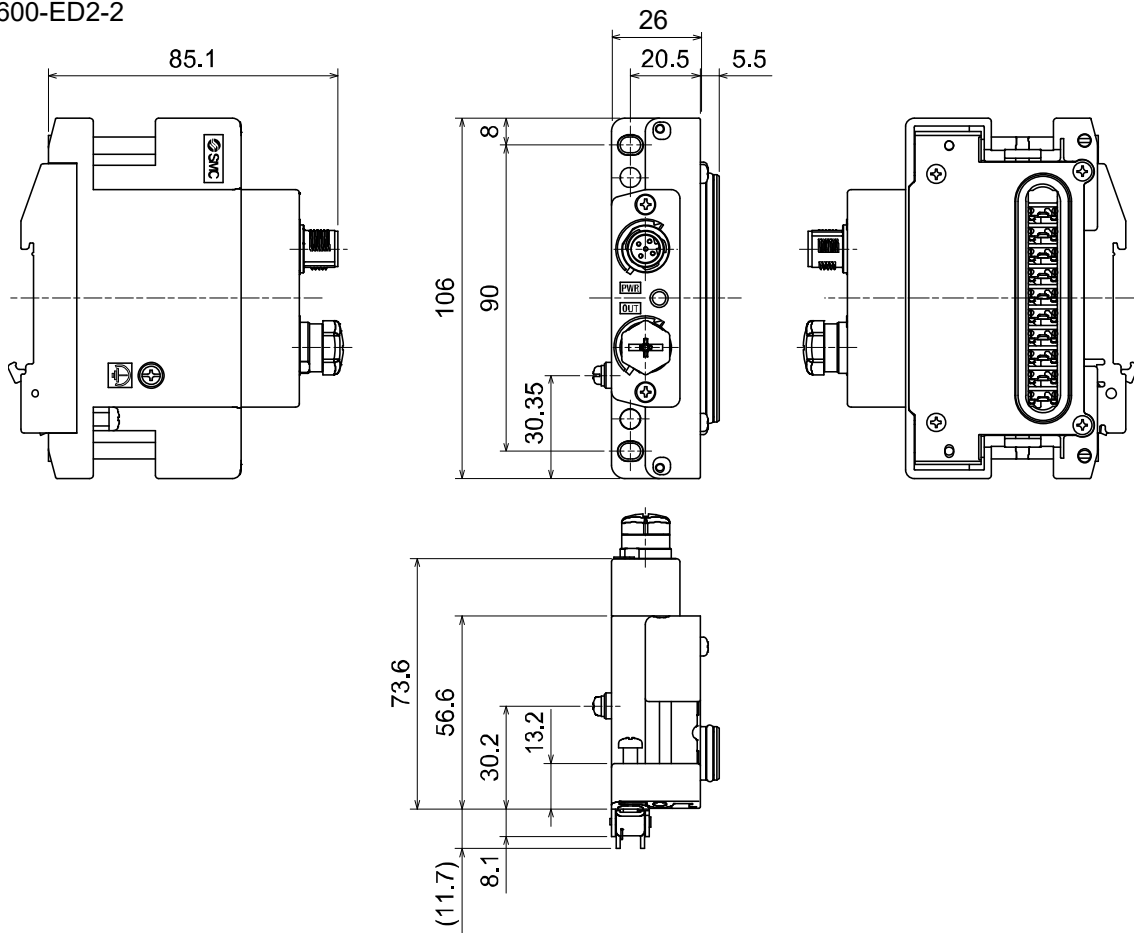

•EX600-ED2-3

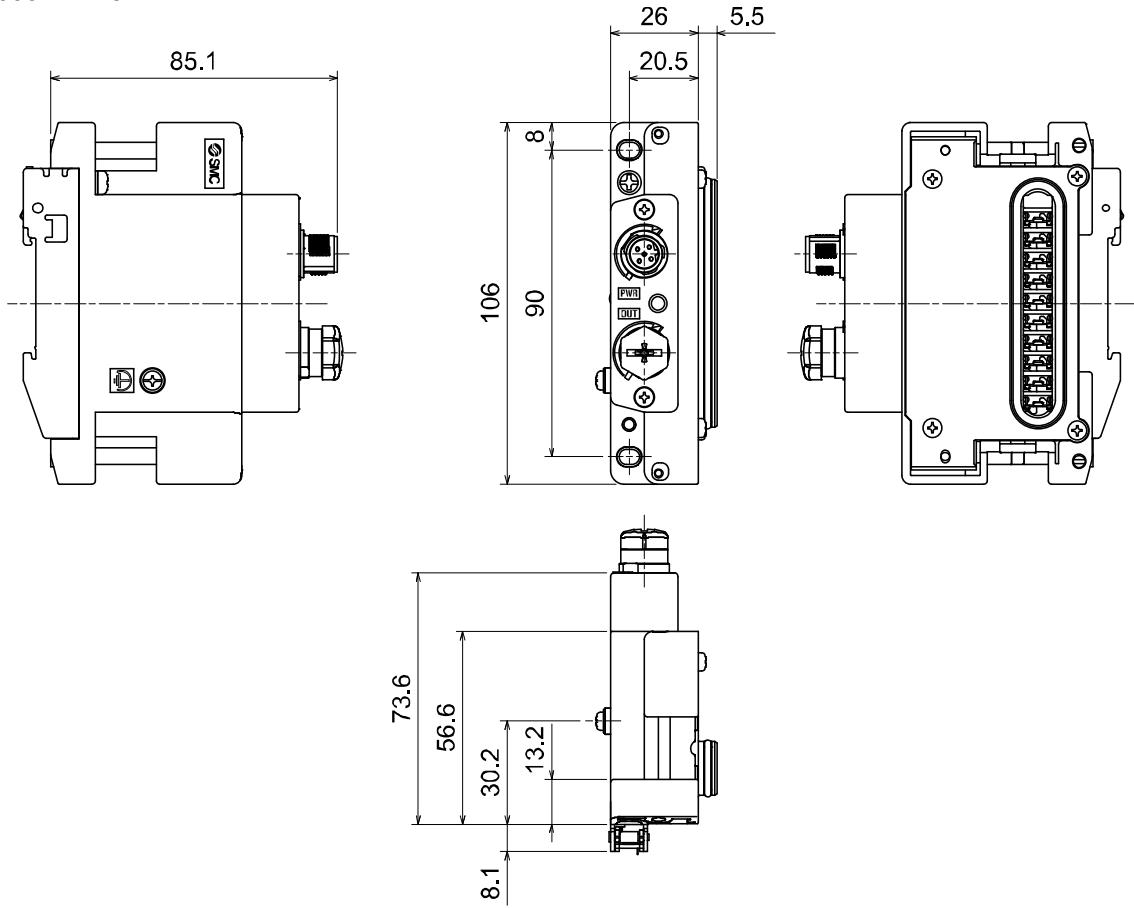

•EX600-ED3

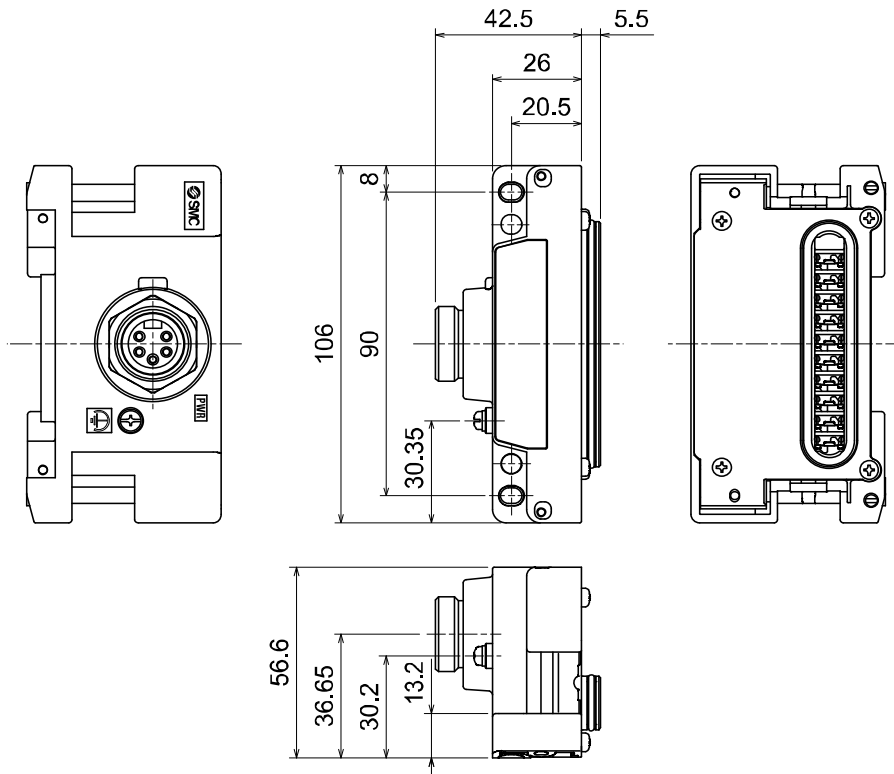

•EX600-ED3-2

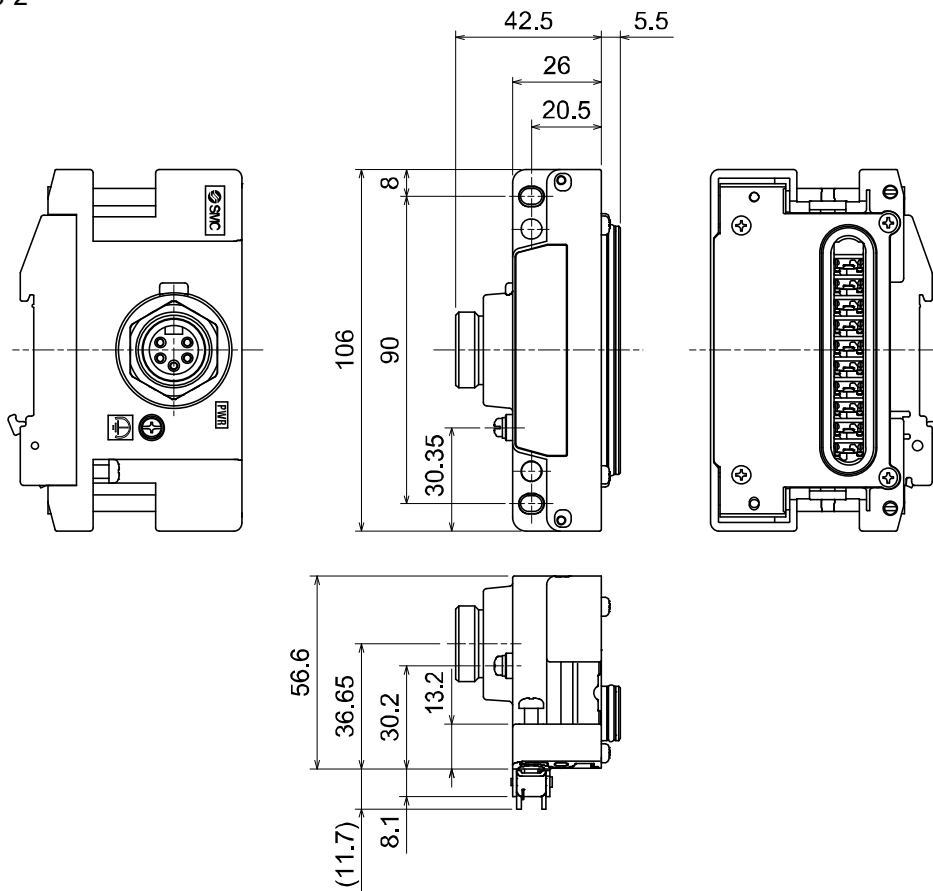

•EX600-ED3-3

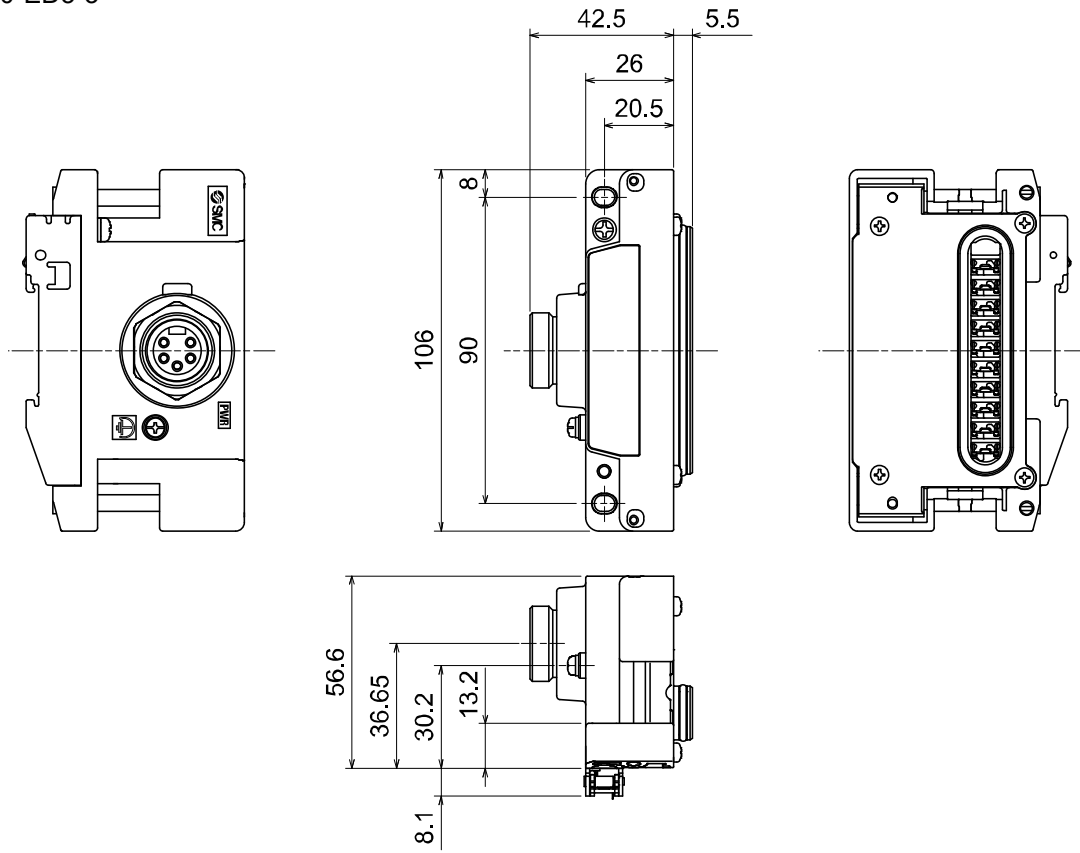

•EX600-ED4/ED5

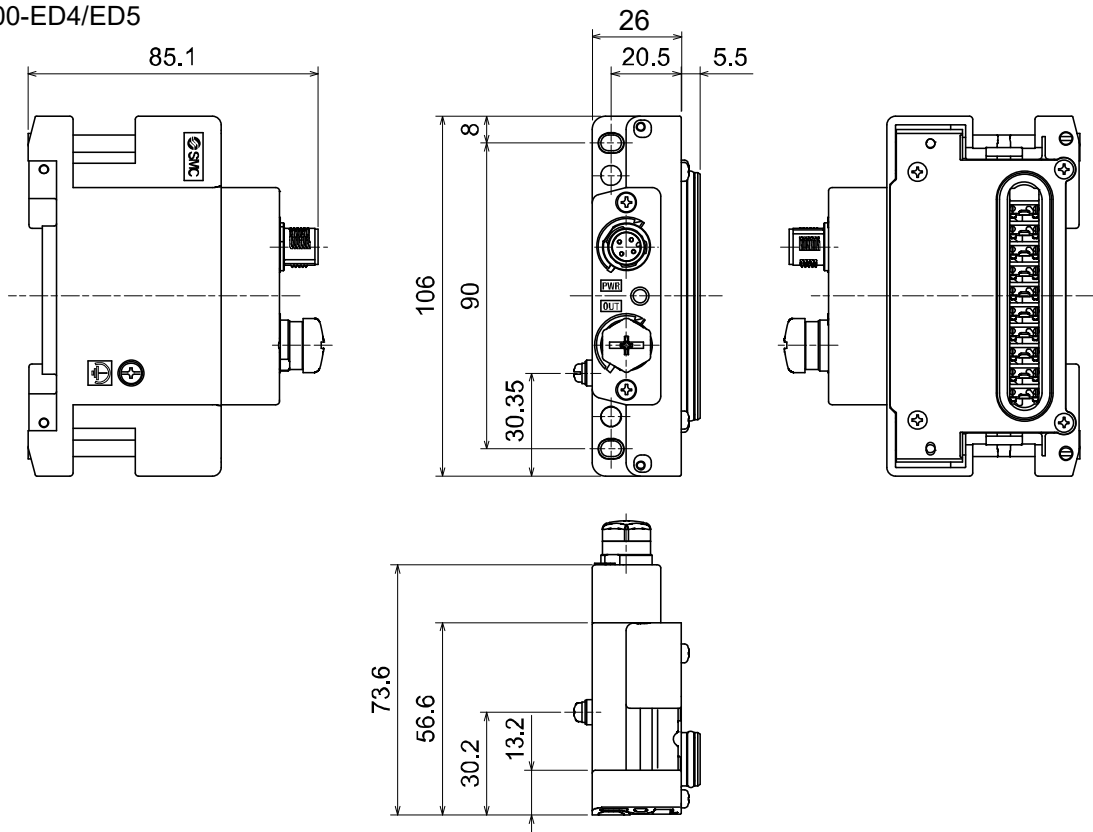

•EX600-ED4/ED5-2

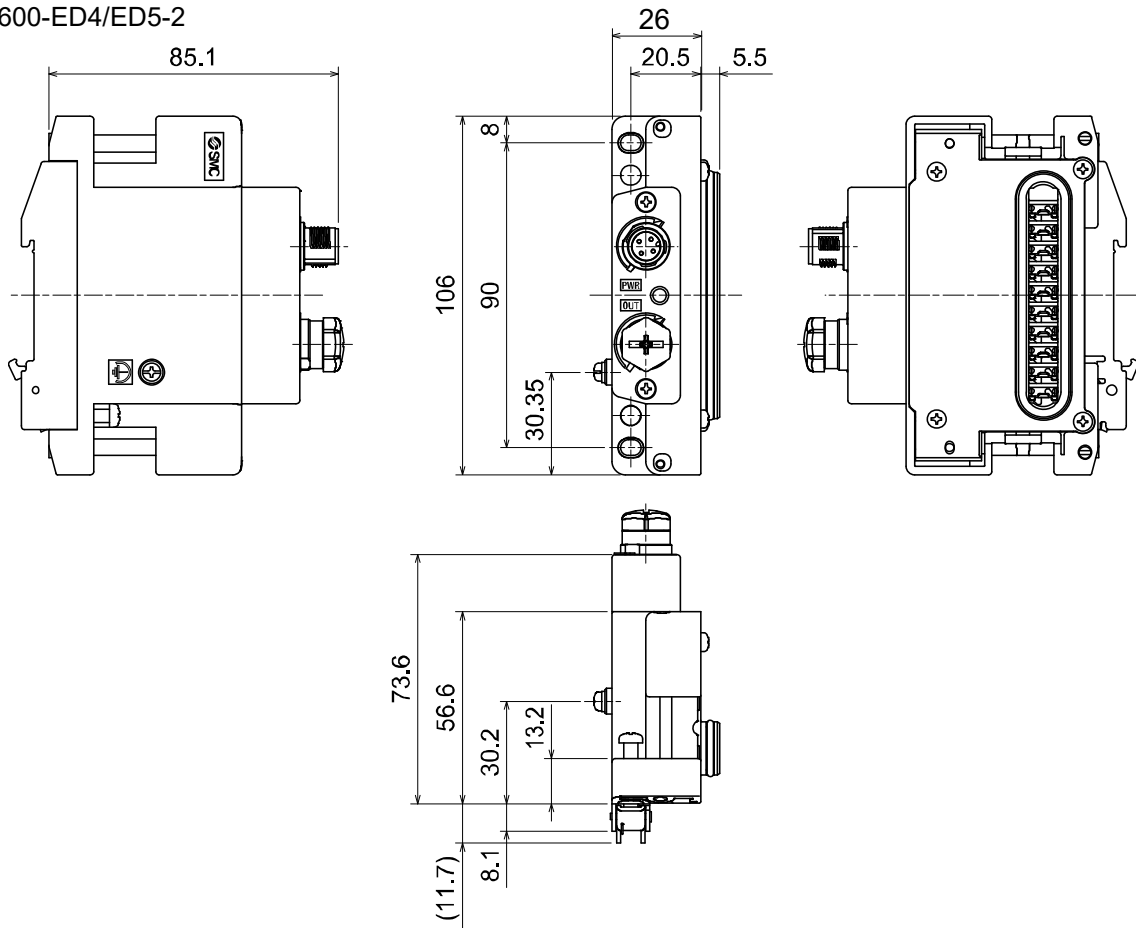



•EX600-ED4/ED5-3

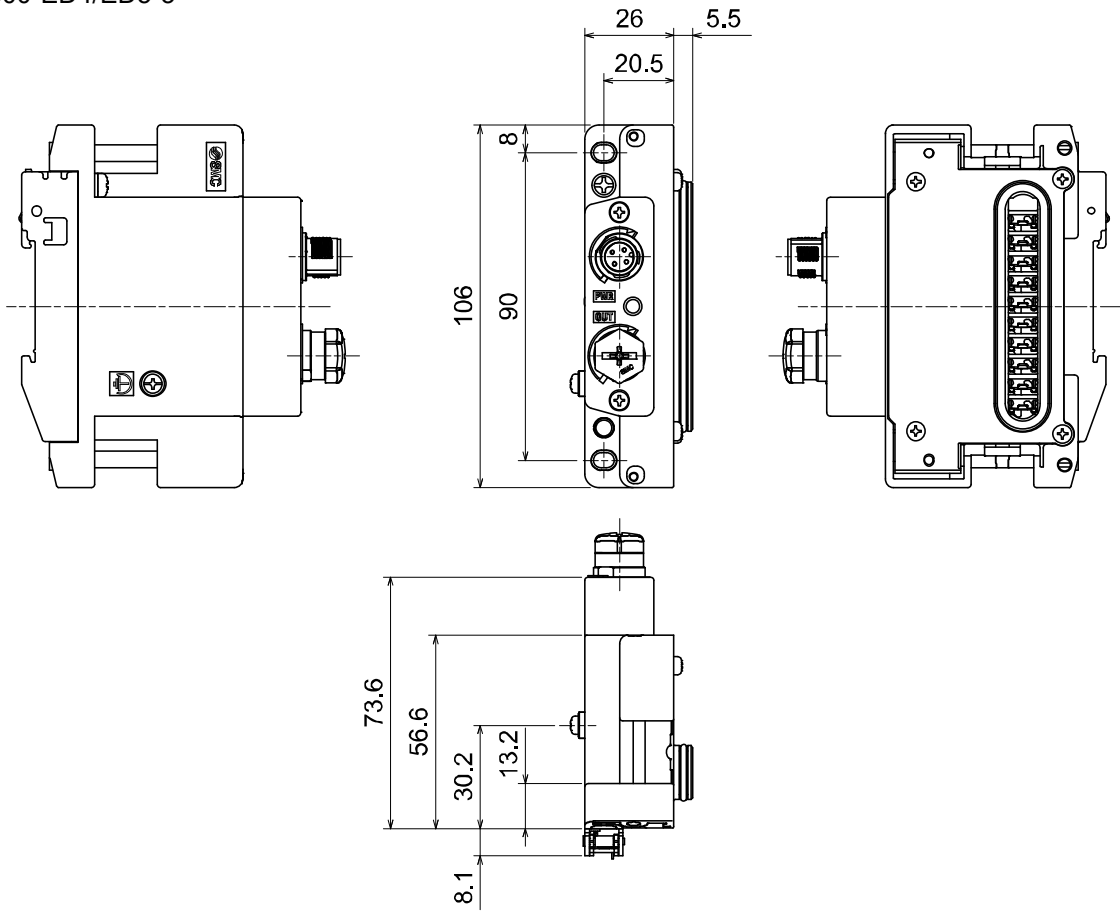

•EX600-EU1

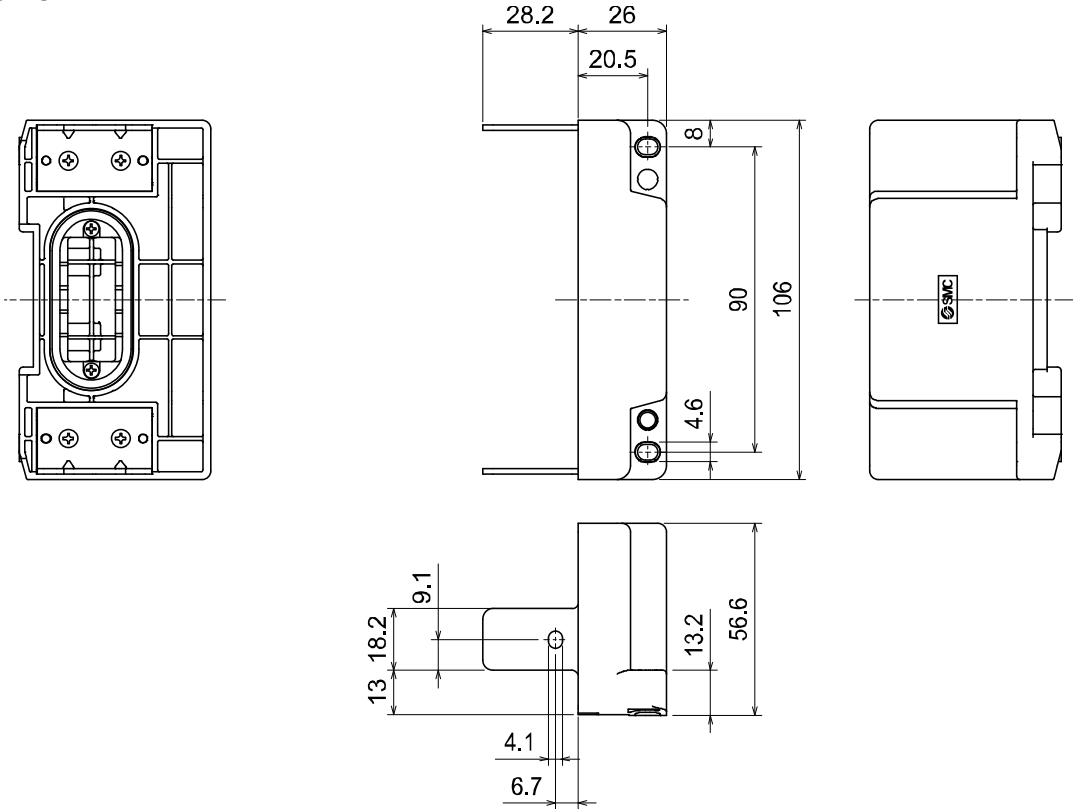

•EX600-EU1-2

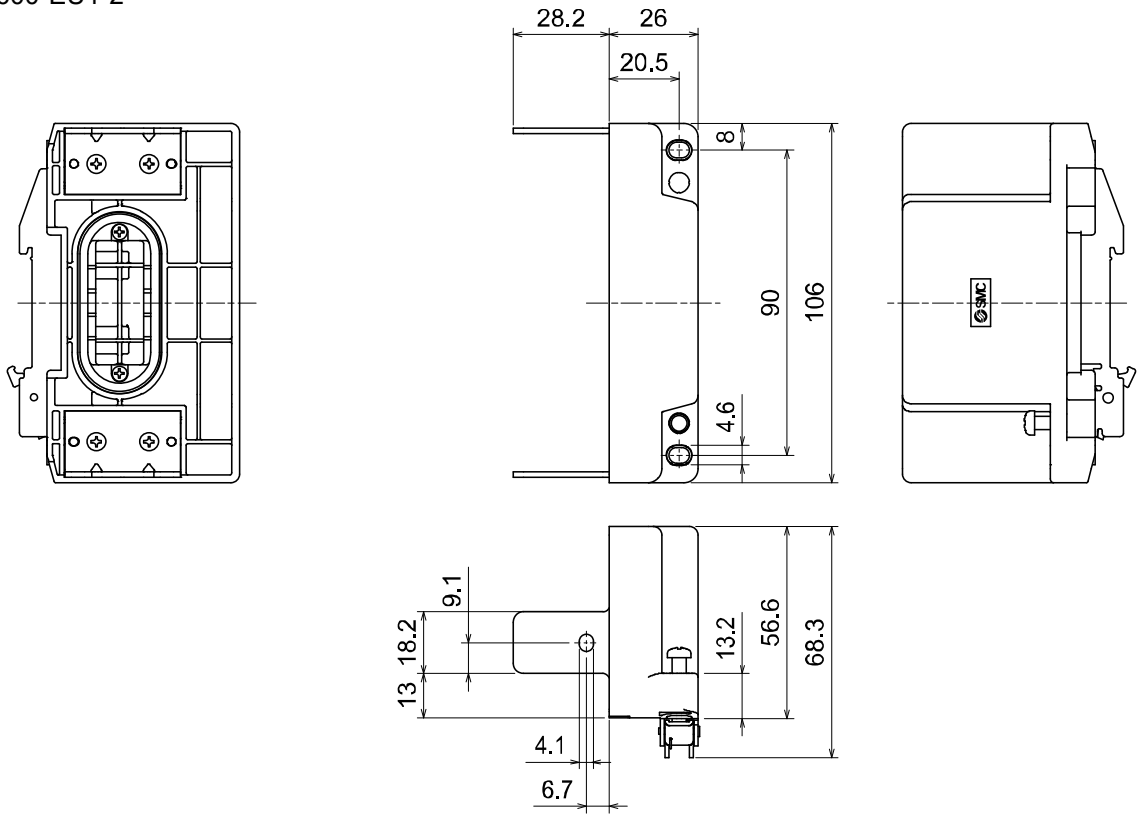

## Maintenance

Turn OFF the power supply, stop the supplied air, exhaust the residual pressure and verify the release of air before performing maintenance.

### Cleaning method

Use a soft cloth to remove stains.

For heavy stains, use a cloth soaked with diluted neutral detergent and fully squeezed, then wipe up the stains again with a dry cloth.

Do not use solvents such as benzene, thinner etc. to clean each unit.

Inspection item	Content of inspection
Connector/Electric wiring	Connect properly if the connection is loose.
Seal cap	Tighten properly if the connection is loose.
Thread for mounting and installation	If the thread is loose, re-tighten it to the specified torque.
Connection cables	If the cable is broken or any other abnormality is confirmed by appearance, replace the cable with a new one.
Supply source voltage	Check if source voltage within the specification range (24 VDC $\pm$ 10%) is supplied.

### How to reset the product for power cut or forcible de-energizing

Supply power to the product.

The output status just before the power failure is not maintained when power supply is recovered.

Start operation after confirming safety of the entire equipment.

# Troubleshooting

## •Troubleshooting

When any failure happens with this Fieldbus system, the following chart is used to identify the cause of the failure.

Error status is reflected from the parameter setting of the Fieldbus system.

When a failure occurs, take the appropriate countermeasures referring to the LED display, the troubleshooting and the parameter setting.

If a cause applicable to the failure cannot be identified, it indicates that the Fieldbus system itself is broken. The Fieldbus system breakage can be caused by the operating environment. Contact SMC separately to obtain countermeasures.

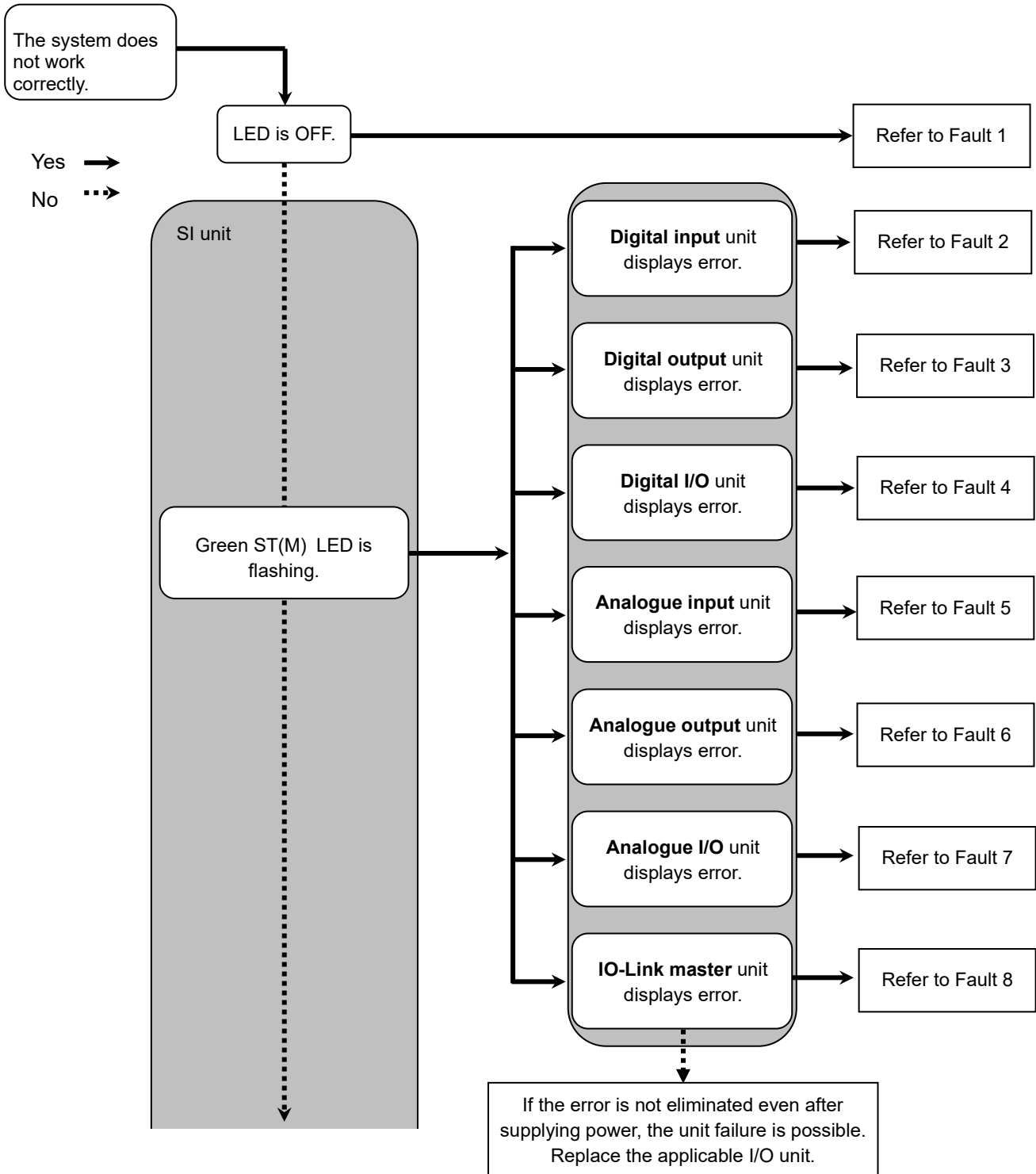

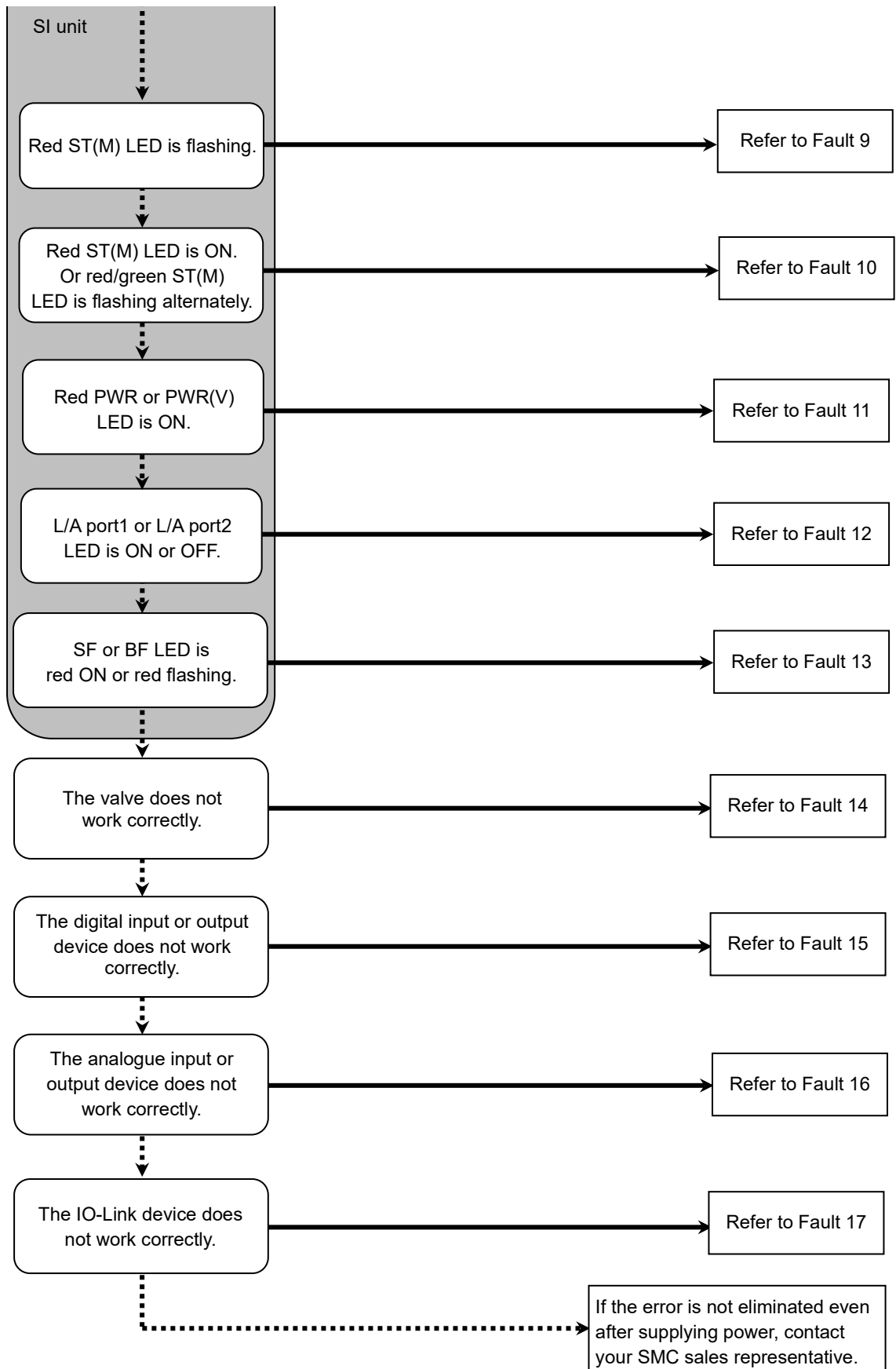

•Trouble counter measure method

No.	Part No. EX600-	Problem	Presumed cause	Troubleshooting
1	-	LED is OFF.	Power supply for control and input is OFF.	Check if the power for control and input is supplied.
2	DX□B DX□C□ DX□D	Red LED is ON. (Diagnosis is activated)	Input device power supply is short-circuited.	Check the parts with error by using the LED display or unit diagnostic data or web server. Re-wire the short-circuited part or check if the cable and input device are normal.
		Red LED is flashing. (Diagnosis is activated)	(1)ON/OFF count of the input device has exceeded the set value. (2)The wire of the input device is broken or disconnected. (Only EX600-DX□C1)	Check the parts with error by using the LED display or unit diagnostic data or web server. (1)Reset the ON/OFF count to zero or change the set value. Or invalidate diagnosis. (2)Check if the connector is loose and if the wire is broken.
		Red/green all LEDs are flashing.	An internal memory error occurred in the Digital input unit.	Turn OFF the power for the unit and then turn it ON again. If the error is not eliminated, stop the operation and contact SMC.
	DX□E DX□F	Red ST LED is ON. (Diagnosis is activated)	Input device power supply is short-circuited.	Check the parts with error by using the LED display or unit diagnostic data or web server. Re-wire the short-circuited part or check if the cable and input device are normal.
		Red ST LED is flashing. (Diagnosis is activated)	ON/OFF count of the input device has exceeded the set value.	Check the parts with error by using the LED display or unit diagnostic data or web server. Reset the ON/OFF count to zero or change the set value. Or invalidate diagnosis.
		Red/green ST LED is flashing.	An internal memory error occurred in the Digital input unit.	Turn OFF the power for the unit and then turn it ON again. If the error is not eliminated, stop the operation and contact SMC.

No.	Part No. EX600-	Problem	Presumed cause	Troubleshooting
3	DY□B	Red LED is ON. (Diagnosis is activated)	Output device is short-circuited.	Check the parts with error by using the LED display or unit diagnostic data or web server. Re-wire the short-circuited part or check if the cable and output device are normal.
		Red LED is flashing. (Diagnosis is activated)	(1)ON/OFF count of the output device has exceeded the set value. (2)The wire of the output device is broken or disconnected.	Check the parts with error by using the LED display or unit diagnostic data or web server. (1)Reset the ON/OFF count to zero or change the set value. Or invalidate diagnosis. (2)Check if the connector is loose and if the wire is broken.
		Red/green all LEDs are flashing.	An internal memory error occurred in the Digital output unit.	Turn OFF the power for the unit and then turn it ON again. If the error is not eliminated, stop the operation and contact SMC.
	DY□E DY□F	Red ST LED is ON. (Diagnosis is activated)	Output device is short-circuited.	Check the parts with error by using the LED display or unit diagnostic data or web server. Re-wire the short-circuited part or check if the cable and output device are normal.
		Red ST LED is flashing. (Diagnosis is activated)	(1)ON/OFF count of the output device has exceeded the set value. (2)The wire of the output device is broken or disconnected.	Check the parts with error by using the LED display or unit diagnostic data or web server. (1)Reset the ON/OFF count to zero or change the set value. Or invalidate diagnosis. (2)Check if the connector is loose and if the wire is broken.
		Red/green ST LED is flashing.	An internal memory error occurred in the Digital output unit.	Turn OFF the power for the unit and then turn it ON again. If the error is not eliminated, stop the operation and contact SMC.
4	DM□E DM□F	Red ST(I) LED is ON. (Diagnosis is activated)	Input device power supply is short-circuited.	Check the parts with error by using the LED display or unit diagnostic data or web server. Re-wire the short-circuited part or check if the cable and input device are normal.
		Red ST(I) LED is flashing. (Diagnosis is activated)	ON/OFF count of the input device has exceeded the set value.	Check the parts with error by using the LED display or unit diagnostic data or web server. Reset the ON/OFF count to zero or change the set value. Or invalidate diagnosis.
		Red ST(O) LED is ON. (Diagnosis is activated)	Output device is short-circuited.	Check the parts with error by using the LED display or unit diagnostic data or web server. Re-wire the short-circuited part or check if the cable and output device are normal.
		Red ST(O) LED is flashing (Diagnosis is activated)	(1)ON/OFF count of the output device has exceeded the set value. (2)The wire of the output device is broken or disconnected.	Check the parts with error by using the LED display or unit diagnostic data or web server. (1)Reset the ON/OFF count to zero or change the set value. Or invalidate diagnosis. (2)Check if the connector is loose and if the wire is broken.
		Red/green ST LED is flashing.	An internal memory error occurred in the Digital input/ output unit.	Turn OFF the power for the unit and then turn it ON again. If the error is not eliminated, stop the operation and contact SMC.

No.	Part No. EX600-	Problem	Presumed cause	Troubleshooting
5	AXA	Red LED is ON. (Diagnosis is activated)	Analogue input device power supply is short-circuited.	Check the parts with error by using the LED display or unit diagnostic data or web server. Re-wire the short-circuited part, and check if the cable and analogue input device are normal.
		"0 and 1" red LEDs are ON.	Input value has exceeded the upper limit when set to current input type range.	Check the following when the range of the Analogue input unit is set to current input. (1)Set the input value of the analogue input device so that it does not exceed the upper limit. (2)Voltage is input from the analogue input device.Ensure the range of the Analogue input unit matches the range of the analogue input device.
		Red LED is flashing. (Diagnosis is activated)	(1)Input value has exceeded the upper or lower limit of the range. (2)Input value (value set by user) has exceeded the upper or lower limit.	(1)If the input value from the analogue input device exceeds the upper or lower limit of the range, select the appropriate range so that the input value is within the range. Or invalidate diagnosis. (2)If the input value from the analogue input device exceeds the upper or lower limit of the user set value, adjust it so that the input value is within the range of the user set value. Or invalidate diagnosis.
		Red/green all LEDs are flashing.	An internal memory error occurred in the Analogue input unit.	Turn OFF the power for the unit and then turn it ON again. If the error is not eliminated, stop the operation and contact SMC.
6	AYA	Red LED is ON. (Diagnosis is activated)	Analogue output device power supply is short-circuited.	Check the parts with error by using the LED display or unit diagnostic data or master. Re-wire the short-circuited part, and check if the cable and analogue output device are normal.
		Red LED is flashing. (Diagnosis is activated)	Output value (value set by user) has exceeded the upper or lower limit.	If the output value from the analogue output device exceeds the upper or lower limit of the user set value, adjust it so that the output value is within the range of the user set value. Or invalidate diagnosis.
		Red/green all LEDs are flashing.	An internal memory error occurred in the Analogue output unit.	Turn OFF the power for the unit and then turn it ON again. If the error is not eliminated, stop the operation and contact SMC.



No.	Part No. EX600-	Problem	Presumed cause	Troubleshooting
7	AMB	Red LED is ON. (Diagnosis is activated)	Analogue input or output device power supply is short-circuited.	Check the parts with error by using the LED display or unit diagnostic data or web server. Re-wire the short-circuited part, and check if the cable and analogue input or output device are normal.
		"0 and 1" red LEDs are ON.	Input value has exceeded the upper limit when set to current input type range.	Check the following when the range of the Analogue input unit is set to current input. (1)Set the input value of the analogue input device so that it does not exceed the upper limit. (2)Voltage is input from the analogue input device. Ensure the range of the input unit matches the range of the input device.
		Red LED is flashing. (Diagnosis is activated)	(1)Input value has exceeded the upper or lower limit of the range. (2)Input or output value (value set by user) has exceeded the upper or lower limit.	(1)If the input value from the analogue input device exceeds the upper or lower limit of the range, select the appropriate range so that the input value is within the range. Or invalidate diagnosis. (2)If the input (output) value from the analogue input (output) device exceeds the upper or lower limit of the user set value, adjust it so that the input (output) value is within the range of the user set value. Or invalidate diagnosis.
		Red/green all LEDs are flashing.	An internal memory error occurred in the Analogue input/ output unit.	Turn OFF the power for the unit and then turn it ON again. If the error is not eliminated, stop the operation and contact SMC.
8	L□B1	Red LED is ON (C/Q or P24) (When diagnostics is valid)	Short circuit of L + power supply or C/Q terminal or P24.	Check the parts showing an error using the LED display or via the Web server. Re-wire the short-circuited part or check if the cable, IO-Link master device or IO-Link device are normal.
		Red and green LEDs are ON alternately.	An internal memory error has occurred in the IO-Link master unit.	Turn off the power to the unit and then turn it on again. If the error is not eliminated, stop using the product and contact your SMC sales representative.

No.	Problem	Presumed cause	Troubleshooting
9	Red ST(M) LED is flashing. (Diagnosis is activated)	(1)Valve is short-circuited. (2)Valve is open-circuited. (3)ON/OFF count of the valve has exceeded the set value.	Check the parts with error by using the LED display or unit diagnostic data or master. (1)Check the operation after replacing the valve. (2)Check the operation after replacing the valve. (3)Reset the ON/OFF count to zero or change the set value. Or invalidate diagnosis.
10	Red ST(M) LED is ON.	SI unit has failed.	Turn OFF the power for the unit and then turn it ON again. If the error is not eliminated, stop the operation and contact SMC.
	Red/Green ST(M) LED is flashing alternately.	Connection error between units is detected.	Confirm that there is no loose connection between the units and connect them correctly.
11	Red PWR LED is ON. (Diagnosis is activated)	Power supply voltage for control and input is out of range.	Supply 24 VDC $\pm$ 10% for control and input power source.
	Red PWR(V) LED is ON. (Diagnosis is activated)	Power supply voltage for output is out of range.	Supply 24 VDC +10/-5% for output power source.
12	L/A port1 or L/A port2 LEDs are OFF.	LINK has not yet been established.	Check the following and restart. (1)Check if the power is supplied to the PROFINET device one level above.(When L/A port1 LED is OFF.) (2)Check that the connectors of L/A port1 and L/A port2 communication cables are connected and there are no broken wires. (3)Keep noise sources away from the communication cable. *: The L/A port2 LED will be OFF if the port2 connector is not used.
	L/A port1 or L/A port2 LED is ON.	LINK is established but data has not been received.	Check the following and restart. (1)Check the master condition and run the master. (2)Check that the communication connector is not loose and there are no broken wires. (3)Keep noise sources away from the communication cable.

No.	Problem	Presumed cause	Troubleshooting
13	SF: Red	Diagnostic error is detected	Check the LED status and eliminate the error by referring to countermeasure No.2 to 7.
	BF: Red flashing	Configuration is not correctly	Check PLC configuration setting so that it matches the actual configuration.
	BF: Red ON	PROFINET communication error	Check the following. <ul style="list-style-type: none"> <li>•Device name setting to PLC and SI unit is not consistent.</li> <li>•The power supply for PLC is OFF.</li> <li>•The communication cable is not connected.</li> <li>•The PLC or SI unit has broken.</li> </ul>
14	The valve does not work correctly.	Program etc. is defective.	Check if the ladder program of master, etc. is correct.
		Power supply for output is out of range.	Check if the green PWR(V) LED of the SI unit is ON. If the LED is off, or the red LED is ON, supply 24 VDC +10/-5% to the power supply for output.
		Connection between SI unit and manifold valve is defective.	Check the connectors between the SI unit and manifold valve are not damaged, such as bent pins, and connect them correctly.
		Polarity of output does not match.	IF the polarity of the SI unit and the valve are different, replace one of them to make the combination match. <ul style="list-style-type: none"> <li>•EX600-SEN3 (PNP output) ⇒ -common type valve</li> <li>•EX600-SEN4 (NPN output) ⇒ +common type valve</li> </ul>
		SI unit has failed.	Replace the SI unit with a normal one, and check the operation.
Valve failure.	Replace the valve with a normal one, and check the operation. Or refer to the troubleshooting of the valve used.		

No.	Problem	Presumed cause	Troubleshooting
15	The digital input device does not work correctly.	Polarity of input does not match.	If the polarity (PNP, NPN) of the input unit and the input device are different, replace one of them to make the combination match.
		Power supply for control and input is out of range.	Check if the green PWR LED of the SI unit is ON. If the LED is off, or the red LED is ON, supply 24 VDC $\pm 10\%$ to the power supply for control and input.
		Wiring or connection is defective.	Connect the wiring correctly between the digital input device and the Digital input unit.
		Input unit has failed.	Replace the input unit with a normal one, and check the operation.
		Input device failure.	Replace the input device with a normal one, and check the operation. Or refer to the troubleshooting of the input device used.
	The digital output device does not work correctly.	Polarity of output does not match.	If the polarity (PNP, NPN) of the output unit and the output device are different, replace one of them to make the combination match.
		Power supply for output is out of range.	Check if the green PWR(V) LED of the SI unit is ON. If the LED is off, or the red LED is ON, supply 24 VDC $+10/-5\%$ to the power supply for output.
		Wiring or connection is defective.	Connect the wiring correctly between the digital output device and the Digital output unit.
		Output unit has failed.	Replace the Output unit with a normal one, and check the operation.
		Output device failure.	Replace the output device with a normal one, and check the operation. Or refer to the troubleshooting of the output device used.
		Program etc. is defective.	Check if the ladder program of master, etc. is correct.

No.	Problem	Presumed cause	Troubleshooting
16	The analogue input device does not work correctly.	Power supply for control and input is out of range.	Check if the green PWR LED of the SI unit is ON. If the LED is off, or the red LED is ON, supply 24 VDC $\pm 10\%$ to the power supply for control and input.
		Analogue input signal range setting failure.	Check the analogue input device specification, and set the input signal range which satisfies the specification.
		Analogue data format does not match.	Check whether the data format of the Analogue input unit is properly set.
		Wiring or connection is defective.	Connect the wiring correctly between the analogue input device and the Analogue input unit.
		Analogue input unit has failed.	Replace the Analogue input unit with a normal one, and check the operation.
		Analogue input device failure.	Replace the analogue input device with a normal one, and check the operation. Or refer to the troubleshooting of the analogue input device used.
	The analogue output device does not work correctly.	Power supply for output is out of range.	Check if the green PWR(V) LED of the SI unit is ON. If the LED is off, or the red LED is ON, supply 24 VDC $+10/-5\%$ to the power supply for output.
		Analogue output signal range setting failure.	Check the analogue output device specification, and set the output signal range which satisfies the specification.
		Analogue data format does not match.	Check whether the data format of the Analogue output unit is properly set.
		Wiring or connection is defective.	Connect the wiring correctly between the analogue output device and the Analogue output unit.
		Analogue output unit has failed.	Replace the Analogue output unit with a normal one, and check the operation.
		Analogue output device failure.	Replace the analogue output device with a normal one, and check the operation. Or refer to the troubleshooting of the analogue output device used.
	Program etc. is defective.	Check if the ladder program of master, etc. is correct.	

No.	Problem	Presumed cause	Troubleshooting
17	LED (C/Q) of EX600-L□B1 is flashing green (1Hz).	In IO-Link mode, •IO-Link device disconnected.	Connect the IO-Link device.
	LED (C/Q) of EX600-L□B1 is flashing green (2 Hz).	In IO-Link mode, •Connected IO-Link device matching error. •Data size error. •Data storage writing error.	•Check the setting of Validation and Backup. •Check the process data of each port of the IO-Link master. When setting the size, it should be more than that of the IO-Link device connected. •Perform writing of the data storage once again.
	LED (C/Q) of the EX600-L□B1 is OFF or turned ON orange.	Port setting is not in the IO-Link communication mode.	For IO-Link communication, set the IO-Link port operation mode to "IOL_Manual" or "IOL_AutoStart".
	IO-Link device operation error.	Power supply for control and input is out of range.	Check if the Power LED of the SI unit is turned ON in green. If the LED is OFF or the red LED is ON, supply 24 VDC +/- 10 % to the power supply for control and input.
		Power supply for output is out of range.	Check if the P24_LED of EX600-LBB1 is turned ON green. If the LED is OFF, supply 24 VDC +/- 5% to the power supply for output.
		Wiring or connection is defective.	Connect the IO-Link master port and IO-Link device correctly.
		IO-Link device failure.	Replace the IO-Link device and check the operation. Or, refer to the troubleshooting of the IO-Link device used.
IO-Link master failure.	Replace the IO-Link master and check the operation.		
Program error.	Check that the ladder logic program works correctly.		

## Parameter Setting

The EX600 parameters can be configured for the each unit and each channel. Parameters can be changed by GSDML file. The table below shows settable parameters for the SI unit and input/output units.

### •SI unit parameters

No.	Parameter	Definition	Item	Content	Default setting	Parameter setting range
1	Power supply for control and input voltage monitor	Generated error when control and input power supply voltage goes under approx. 19 V.	Enable	Generates an error.	○	Unit
			Disable	Does not generate an error.		
2	Power supply for output voltage monitor	Generated error when output power supply voltage goes under approx. 19 V.	Enable	Generates an error.		Unit
			Disable	Does not generate an error.	○	
3	Short Circuit Detection	Generates error when the short circuit of the valve is detected.	Enable	Generates an error.	○	Unit
			Disable	Does not generate an error.		
4	Restart after short circuit	Restore the setting of short circuit detection error after the valve short circuit is cleared.	Auto	Error is automatically cleared when the short circuit is fixed.	○	Unit
			Manual	Even when the short circuit is fixed, error is not cleared until the power is supplied again.		
5	Open Circuit Detection	Generates error when the disconnection of the valve is detected.	Enable	Generates an error.		Channel
			Disable	Does not generate an error.	○	
6	Output setting during communication fault *1	Sets output when communication error is occurred.	Clear	Turn off the output	○	Channel
			Hold	Hold the output		
			ForceON	Turn on the output forcefully		
8	Valve ON/OFF counter	Generates error when the operation count exceeds the set value. *1	Enable	Generates an error. Val: 1 to 65000 *2		Channel
			Disable	Does not generate an error.	○	
9	Valve ON/OFF counter clear	Clears the valve ON/OFF counter to 0. (Refer to page 89 for the clear method).	-	-	-	-

\*1: The count is memorized every hour. When the power supply is turned on again, counting starts from the last value memorized.

\*4: Times for setting is set value x1000 times.

•Digital input unit parameters

No.	Parameter	Definition	Item	Content	Default setting	Parameter setting range
1	The power supply short circuit detection for control and input	Generates error when the short circuit of the power supply for the input device is detected.	Enable	Generates an error.	○	Unit
			Disable	Does not generate an error.		
2	Open circuit detection *1	Generates error when the disconnection of the input device is detected. *2	Enable	Generates an error.	○	Channel
			Disable	Does not generate an error.		
3	Inrush current filter	Selects the over current detection for 100 msec after supplying power.	Enable	Ignores inrush current.	○	Unit
			Disable	Does not ignore inrush current.		
4	Input filtering time	Sets the time to ignore the input signal change.	0.1 ms	Selects the time for filtering.	1.0 ms	Unit
			1.0 ms			
			10 ms			
			20 ms			
5	Input extension time	Sets the time to hold the input signal.	1.0ms	Selects the time to hold the input signal.	15 ms	Unit
			15 ms			
			100 ms			
			200 ms			
6	Input ON/OFF counter	Generates error when the operation count exceeds the set value. *3	Enable	Generates an error. Val: 1 to 65000 *4	○	Channel
			Disable	Does not generate an error.		
7	Input ON/OFF counter clear	Clears the Input ON/OFF counter to 0. (Refer to page 89 for the clear method).	-	-	-	-

\*1: Disconnection detection is a function only available for digital unit (EX600-DXPC1, EX600-DXNC1) with disconnection detection.

\*2: 2-wire type input equipment cannot be correctly detected if its leakage current is 0.5 mA or less while the equipment is in the OFF state (reed sensor, etc.).

Ensure that all input equipment used has a leakage current above 0.5 mA in the OFF state.

3-wire type input equipment cannot be correctly detected if its current consumption is 0.5 mA or less.

The open circuit of input signals cannot be detected.

\*3: The count is memorized every hour. When the power supply is turned on again, counting starts from the last value memorized.

\*4: Times for setting is set value x1000 times.



•Digital output unit parameters

No.	Parameter	Definition	Item	Content	Default setting	Parameter setting range
1	Output load short circuit detection	Generates error when the short circuit of the output device is detected. *1	Enable	Generates an error.	○	Unit
			Disable	Does not generate an error.		
2	Restart after output load short circuit	Restore the setting of short circuit detection error after the output device short circuit is cleared.	Auto	Error is automatically cleared when the short circuit is fixed.	○	Unit
			Manual	Even when the short circuit is fixed, error is not cleared until the power is supplied again.		
3	Open circuit detection	Generates error when the disconnection of the output device is detected.	Enable	Generates an error.		Channel
			Disable	Does not generate an error.	○	
4	Output setting during communication fault *2	Sets output when communication error is occurred.	Clear	Turn off the output	○	Channel
			Hold	Hold the output		
			ForceON	Turn on the output forcefully		
5	Output ON/OFF counter	Generates error when the operation count exceeds the set value. *2	Enable	Generates an error. Val: 1 to 65000 *3		Channel
			Disable	Does not generate an error.	○	
6	Output ON/OFF counter clear	Clears the Output ON/OFF counter to 0. (Refer to page 89 for the clear method).	-	-	-	-

\*1: Could be incorrectly recognized as short circuit depending on used load (ex.: lamp load). If detection is incorrect, disable the parameter setting.

\*2: The count is memorized every hour. When the power supply is turned on again, counting starts from the last value memorized.

\*3: Times for setting is set value x1000 times.

•Digital I/O unit parameters (1)

No.	Parameter	Definition	Item	Content	Default setting	Parameter setting range
1	The power supply short circuit detection for control and input	Generates error when the short circuit of the control or input power supply is detected.	Enable	Generates an error.	○	Unit
			Disable	Does not generate an error.		
2	Inrush current filter	Select the over current detection for 100 msec after supplying power.	Enable	Ignores inrush current.		Unit
			Disable	Does not ignore inrush current.	○	
3	Input filtering time	Sets the time to ignore the input signal change.	0.1 ms	Selects the time for filtering.	1.0 ms	Unit
			1.0 ms			
			10 ms			
			20 ms			
4	Input extension time	Sets the time to hold the input signal.	1.0 ms	Selects the time to hold the input signal.	15 ms	Unit
			15 ms			
			100 ms			
			200 ms			
5	Output load short circuit detection	Generates error when the short circuit of the output device is detected. *1	Enable	Generates an error.	○	Unit
			Disable	Does not generate an error.		
6	Restart after output load short circuit	Restore the setting of short circuit detection error after the output device short circuit is cleared.	Auto	Error is automatically cleared when the short circuit is fixed.	○	Unit
			Manual	Even when the short circuit is fixed, error is not cleared until the power is supplied again.		
7	Open circuit detection	Generates error when the disconnection of the output device is detected.	Enable	Generates an error.		Channel
			Disable	Does not generate an error.	○	
8	Output setting during communication fault	Sets output when Communication error is occurred.	Clear	Turn off the output	○	Channel
			Hold	Hold the output		
			ForceON	Turn on the output forcefully		

•Digital I/O unit parameters (2)

No.	Parameter	Definition	Item	Content	Default setting	Parameter setting range
9	Input or Output ON/OFF counter	Generates error when the operation count exceeds the set value. *2	Enable	Generates an error. Val: 1 to 65000 *3		Channel
			Disable	Does not generate an error.	○	
10	Input or Output ON/OFF counter clear	Clears the Input or Output ON/OFF counter to 0. (Refer to page 89 for the clear method).	-	-	-	-

\*1: Could be incorrectly recognized as short circuit depending on used load (ex.: lamp load). If detection is incorrect, disable the parameter setting.

\*2: The count is memorized every hour. When the power supply is turned on again, counting starts from the last value memorized.

\*3: Times for setting is set value x1000 times.

•Analogue input unit parameters

No.	Parameter	Definition	Item	Content	Default setting	Parameter setting range
1	The power supply short circuit detection for the input device	Generates error when the short circuit of the power supply for the input device is detected.	Enable	Generates an error.	○	Unit
			Disable	Does not generate an error.		
2	Analogue input range	Sets the analogue input device range.	-10..10 V	Selects the analogue input range.	-10..10 V	Channel
			-5..5 V			
			-20..20 mA			
			0..10 V			
			0..5 V			
			1..5 V			
			0..20 mA			
4..20 mA						
3	Analogue data format	Sets analogue data type which is output to PLC.	Offset binary	Offset binary.	○	Unit
			Sign & Magnitude	Signed binary.		
			2s complement	2's complement.		
4	Analogue average filter	Sets analogue filtering time.	None	None	○	Channel
			2AVG	2 value average		
			4AVG	4 value average		
			8AVG	8 value average		
5	Over range detection	Generates error when the input value exceeds 0.5% of full span.	Enable	Generates an error.	○	Unit
			Disable	Does not generate an error.		
6	Under range detection	Generates error when the input value falls below 0.5% of full span.	Enable	Generates an error.	○	Unit
			Disable	Does not generate an error.		
7	User setting value upper limit error	Generates error when the input value exceeds the set value.	Enable	Generates an error. *1		Channel
			Disable	Does not generate an error.	○	
8	User setting value lower limit error	Generates error when the input value falls below the set value.	Enable	Generates an error. *1		Channel
			Disable	Does not generate an error.	○	

\*1: Set value shall be set per analogue input range within settable range in the table below.

When the analogue input range is changed, check the set value and change it to an appropriate value.

Table. Settable range of user set value

Range	Settable value range	
	Lower limit	Upper limit
-10..+10 V	-10.50 to +10.45 V	-10.45 to +10.50 V
-5..+5 V	-5.25 to +5.22 V	-5.22 to +5.25 V
-20..+20 mA	-21.00 to +20.90 mA	-20.90 to +21.00 mA
0..10 V	0.00 to +10.45 V	+0.05 to +10.50 V
0.5 V	0.00 to +5.22 V	+0.03 to +5.25 V
1..5 V	+0.75 to +5.22 V	+0.78 to +5.25 V
0..20 mA	0.00 to +20.90 mA	+0.10 to +21.00 mA
4..20 mA	+3.00 to +20.90 mA	+3.10 to +21.00 mA

Range	Via GSDML file *1	Expected value
-10..+10 V	0 to 1050 32768 to 33818	+0.00 to +10.50 V -0.00 to -10.50 V
-5..+5 V	0 to 525 32768 to 33293	+0.00 to +5.25 V -0.00 to -5.25 V
-20..+20 mA	0 to 2100 32768 to 34868	+0.00 to +21.00 mA -0.00 to -21.00 mA
0..10 V	0 to 1050	+0.00 to +10.50 V
0.5 V	0 to 525	+0.00 to +5.25 V
1..5 V	75 to 525	+0.75 to +5.25 V
0..20 mA	0 to 2100	+0.00 to +21.00 mA
4..20 mA	300 to 2100	+3.00 to +21.00 mA

\*1: Follow the methods below when assigning the user set upper and lower limit by GSDML file.

- Assigning positive value: Input the required data x 100 in decimal system.

Example: +10.50 V is assigned --- Assign  $10.50 \times 100 = 1050$  by GSDML file.

- Assigning negative value: Convert the absolute value x 100 to be assigned in 16bit binary. Then, change the most significant bit to "1" before inputting.

Example: -10.50 V is assigned --- Assign  $10.50 \times 100 = 1050 \rightarrow 10000011010b \rightarrow 1000010000011010b \rightarrow 33818$  by GSDML file.

•Analogue output unit parameters

No.	Parameter	Definition	Item	Content	Default setting	Parameter setting range
1	The power supply short circuit detection for the output device	Generates error when the short circuit of the output device is detected.	Enable	Generates an error.	○	Unit
			Disable	Does not generate an error.		
2	Analogue output range	Sets the range of the analogue output device.	0..10 V	Selects the analogue output range.	0..10 V	Channel
			0..5 V			
			1..5 V			
			0..20 mA			
			4..20 mA			
3	Analogue data format	Sets analogue data type which is output to PLC.	Offset binary	Offset binary.	○	Unit
			Sign & Magnitude	Signed binary.		
			2s complement	2's complement.		
			Scaled	Scale conversion type.		
4	User setting value upper limit error	Generates error when the output value exceeds the set value.	Enable	Generates an error. *1	○	Channel
			Disable	Does not generate an error.		
	Scale upper limit setting	Sets the scale upper limit. Generates error when the output value exceeds the upper limit.	Enable	Generates an error. Val: -32766 to 32767	○ Val: 1000	
			Disable	Does not generate an error. Val: -32766 to 32767		
5	User setting value lower limit error	Generates error when the output value falls below the set value.	Enable	Generates an error. *1	○	Channel
			Disable	Does not generate an error.		
	Scale lower limit setting	Sets the scale lower limit. Generates error when the output value falls below the lower limit.	Enable	Generates an error. Val: -32767 to 32766	○ Val: 0	
			Disable	Does not generate an error. Val: -32767 to 32766		
6	Output setting for communication error	Sets output when communication error is occurred.	Enable	Output will be user fault value. *1	○	Channel
			Disable	Output will be held last state.		

\*1: Set value shall be set per analogue input range within settable range in the next page table.

When the analogue input range is changed, check the set value and change it to an appropriate value.

Settable range for user set upper or lower limit and output value at communication error

Range	Settable range for user set upper or lower limit		Settable range for output value at communication error
	Lower limit	Upper limit	
0..10 V	0.00 to +10.45 V	+0.05 to +10.50 V	0.00 to +10.50 V
0..5 V	0.00 to +5.22 V	+0.03 to +5.25 V	0.00 to +5.25 V
1..5 V	+0.75 to +5.22 V	+0.78 to +5.25 V	+0.75 to +5.25 V
0..20 mA	0.00 to +20.90 mA	+0.10 to +21.00 mA	0.00 to +21.00 mA
4..20 mA	+3.00 to +20.90 mA	+3.10 to +21.00 mA	+3.00 to +21.00 mA

Correspondence table for user set upper or lower limit and output value at communication error  
(Data format: other than scale conversion format)

Range	Set value (Offset Binary Signed Magnitude 2's Complement)	Expected value
0..10 V	0 to 1050	0.00 to +10.50 V
0..5 V	0 to 525	0.00 to +5.25 V
1..5 V	75 to 525	+0.75 to +5.25 V
0..20 mA	0 to 2100	0.00 to +21.00 mA
4..20 mA	300 to 2100	+3.00 to +21.00 mA

\*: When the data format is a type other than scale conversion, input the desired voltage or current x 100 in decimal system.

\*: If the data format is scaled data format, set the data as follows, regardless of the range setting.

Correspondence table for user set upper or lower limit and output value at communication error  
(Data format: scale conversion format)

Set value	Expected value
0 to 32767	+0 to +32767
32768 to 65535	-0 to -32767

■ Scaled data format

Function to set any value between "-32767 to 32767" as the AD value for output signal range. Resolution is determined by specifying the upper and lower scale limit.

$$\text{Resolution} = \frac{\text{Upper limit value of the range} - \text{Lower limit value of the range}}{\text{Upper limit value of the scale} - \text{Lower limit value of the scale}}$$

Example: when the range is 1 to 5 V output

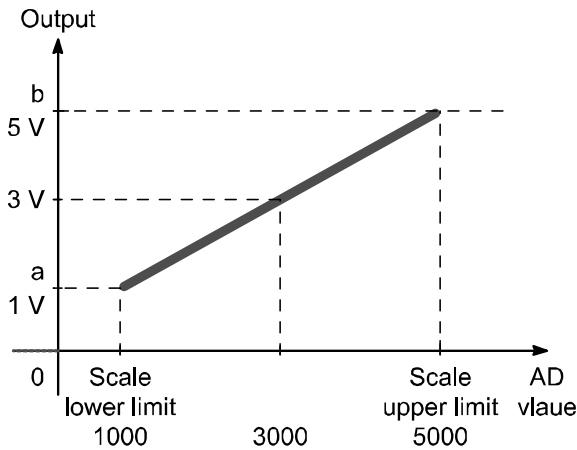

- (1) Set the range to 1 to 5 V.
- (2) When the upper limit of the scale is set to 5000, and the lower limit of the scale is set to 1000, the result will be as follows.
  - 1000 ··· 1 V output
  - 2000 ··· 2 V output
  - 3000 ··· 3 V output
  - 4000 ··· 4 V output
  - 5000 ··· 5 V output
- (3) The resolution from 1 to 5 V is 1/1000 based on the calculation.
 
$$(5\text{ V} - 1\text{ V}) / (5000 - 1000) = 1/1000$$

Scale set value (AD value)		Output signal range (a to b)				
		Voltage [V]			Current [mA]	
	Decimal number	0 to 10	1 to 5	0 to 5	0 to 20	4 to 20
Scale upper limit	-32766 to 32767	10	5	5	20	20
Scale lower limit	-32767 to 32766	0	1	0	0	4

If the data format is scaled data format, set the data as follows, regardless of the range setting.

Correspondence table for scale upper or lower limit and output value at communication error  
(Data format: scale conversion format)

Set value	Expected value
0 to 32767	+0 to +32767
32768 to 65535	-0 to -32767

Example: To set the Fault Value to 4 V when the range is 1 to 5 V (analogue output range), scale upper limit 5000, and scale lower limit 1000, set 4000 to Fault Value using the GSDXML file.



•Analogue I/O unit parameters (1)

No.	Parameter	Definition	Item	Content	Default setting	Parameter setting range
1	The power supply short circuit detection for the input or output device	Generates error when the short circuit of the input device power supply or output device is detected.	Enable	Generates an error.	○	Unit
			Disable	Does not generate an error.		
2	Analogue input or output range	Sets the analogue input or output range.	0..10 V	Select the analogue input or output range.	1..5 V	Channel
			0..5 V			
			1..5 V			
			0..20 mA			
			4..20 mA			
3	Analogue data format	Sets analogue data type which is output to PLC.	Offset binary	Offset binary.	○	Unit
			Sign & Magnitude	Signed binary.		
			2s complement	2's complement.		
			Scaled	Scale conversion type.		
4	Analogue average filter	Sets analogue input filtering time.	None	None		Channel
			2AVG	2 value average	○	
			4AVG	4 value average		
			8AVG	8 value average		
5	Over range detection	Generates error when the input value exceeds 0.5% of full span.	Enable	Generates an error.		Unit
			Disable	Does not generate an error.	○	
6	Under range detection	Generates error when the input value falls below 0.5% of full span.	Enable	Generates an error.		Unit
			Disable	Does not generate an error.	○	
7	User's set value upper limit error	Generates error when the input or output value exceeds the set value.	Enable	Generates an error. *1		Channel
			Disable	Does not generate an error.	○	
	Scale upper limit setting	Sets the scale upper limit. Generates error when the input or output value exceeds the upper limit.	Enable	Generates an error. Val: -32766 to 32767		
			Disable	Does not generated an error. Val: -32766 to 32767	○ Val: 1000	

•Analogue I/O unit parameters (2)

No.	Parameter	Definition	Item	Content	Default setting	Parameter setting range
8	User's set value lower limit error	Generates error when the input or output value falls below the lower limit.	Enable	Generates an error. *1		Channel
			Disable	Does not generate an error.	○	
	Scale lower limit setting	Sets the scale lower limit. Generates error when the input or output value falls below the lower limit.	Enable	Generates an error. Val: -32767 to 32766		
			Disable	Does not generate an error. Val: -32767 to 32766	○ Val: 0	
9	Output setting for communication fault	Sets output when communication error is occurred.	Enable	Output will be user fault value. *1		Channel
			Disable	Output will be held last state.	○	

\*1: Set value shall be set per analogue output range within settable range in the next page table.

When the analogue output range is changed, check the set value and change it to an appropriate value.

Settable range for user set upper or lower limit and output value at communication error

Range	Settable range for user set upper or lower limit		Settable range for output value at communication error
	Lower limit	Upper limit	
0..10 V	0.00 to +10.45 V	+0.05 to +10.50 V	0.00 to +10.50 V
0..5 V	0.00 to +5.22 V	+0.03 to +5.25 V	0.00 to +5.25 V
1..5 V	+0.75 to +5.22 V	+0.78 to +5.25 V	+0.75 to +5.25 V
0..20 mA	0.00 to +20.90 mA	+0.10 to +21.00 mA	0.00 to +21.00 mA
4..20 mA	+3.00 to +20.90 mA	+3.10 to +21.00 mA	+3.00 to +21.00 mA

Correspondence table for user set upper or lower limit and output value at communication error  
(Data format: other than scale conversion format)

Range	Value (Offset Binary Signed Magnitude 2's Complement)	Expected value
0..10 V	0 to 1050	0.00 to +10.50 V
0..5 V	0 to 525	0.00 to +5.25 V
1..5 V	75 to 525	+0.75 to +5.25 V
0..20 mA	0 to 2100	0.00 to +21.00 mA
4..20 mA	300 to 2100	+3.00 to +21.00 mA

\*: When the data format is a type other than scale conversion, input the required voltage or current x 100 in decimal system.

\*: If the data format is scaled data format, set the data as follows, regardless of the range setting.

Correspondence table for user set upper or lower limit and output value at communication error  
(Data format: scale conversion format)

Set value	Expected value
0 to 32767	+0 to +32767
32768 to 65535	-0 to -32767

■ Scaled data format

Function to set any value between "-32767 to 32767" as the AD value for I/O signal range. Resolution is determined by specifying the upper and lower scale limit.

$$\text{Resolution} = \frac{\text{Upper limit value of the range} - \text{Lower limit value of the range}}{\text{Upper limit value of the scale} - \text{Lower limit value of the scale}}$$

Example: when the range is 1 to 5 V output

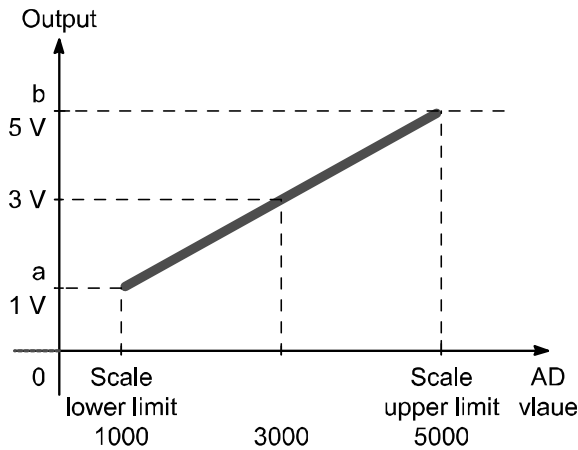

- (1) Set the range to 1 to 5 V.
- (2) When the upper limit of the scale is set to 5000, and the lower limit of the scale is set to 1000, the result will be as follows.
  - 1000...1 V output
  - 2000...2 V output
  - 3000...3 V output
  - 4000...4 V output
  - 5000...5 V output
- (3) The resolution from 1 to 5 V is 1/1000 based on the calculation.
 
$$(5 \text{ V} - 1 \text{ V}) / (5000 - 1000) = 1/1000$$

Scale set value (AD value)		Input/Output signal range (a to b)				
	Decimal number	Voltage [V]			Current [mA]	
		0 to 10	1 to 5	0 to 5	0 to 20	4 to 20
Scale upper limit	-32766 to 32767	10	5	5	20	20
Scale lower limit	-32767 to 32766	0	1	0	0	4

If the data format is scaled data format, set the data as follows, regardless of the range setting.

Correspondence table for scale upper or lower limit and output value at communication error

(Data format: scale conversion format)

Set value	Expected value
0 to 32767	+0 to +32767
32768 to 65535	-0 to -32767

Example: To set the Fault Value to 4 V when the range is 1 to 5 V (analogue output range), scale upper limit 5000, and scale lower limit 1000, set 4000 to Fault Value using the PLC.

•IO-Link master unit parameters (1)

No.	Parameter	Definition	Item	Content	Default setting	Parameter setting range
1	Short Circuit Monitor	If a shortc circuit is detected on any of the following, a diagnostic will be generated. •L+ power supply •C/Q signal •P24 power supply	Enable	Generate diagnostics	○	Unit
			Disable	No diagnostics		
2	Output setting under PROFINET communication fault (IO-Link)*1	Setting for IO-Link output process data behaviour when PROFINET communication errors are detected.	Clear/ PD Out valid	All outputs are turned OFF and process data outputs remain valid		Channel
			Hold	Process data outputs remain valid. IO-link master holds the last process data it received		
			Clear/ PD Out invalid	All outputs are turned OFF and Process data outputs become invalid	○	
3	Output setting under PROFINET communication error (DO_C/Q)	Setting for digital outputs signal behaviour when PROFINET communication errors are detected.	Clear	Turn OFF the digital output.	○	Channel
			Hold	Hold the last output signal which IO-link master received		
			Force ON	Turn ON the digital output.		
4	Port configuration without IO-Link Device Tool	Setting method for IO-Link master port parameters via the GSDML file or the IO-Link Device Tool.	<input checked="" type="checkbox"/>	Via GSDML file	○	Channel
			<input type="checkbox"/>	Via IO-Link Device Tool		

•IO-Link master unit parameters (2)

No.	Parameter	Definition	Item	Content	Default setting	Parameter setting range
5	In/Out Byte Swap *1	Swap the byte order of the process data, which is exchanged between PROFINET communication and IO-Link master.	Direct	Data order is not swapped.	○	Channel
			Swap 16 bit	Swapped by word.		
			Swap 32 bit	Swapped by double word.		
			Swap All	All bytes swapped.		
6	PortMode	Setting the operation mode for each port.	Manual	Start-up IO-LINK communication based on the IO-Link device comparison function.		Channel
			Autostart	Start up the IO-Link communication without comparing IO-Link device.	○	
7	Validation & Backup *3	Setting for the connected device comparison function (comparison of vendor ID and device ID) And setting for the data storage (DS).	No Device Check	Comparison function: invalid DS function: invalid	○	Channel
			Type compatible Device V1.0	Connected device: V1.0 Comparison function: valid DS function: invalid		
			Type compatible Device V1.1	Connected device: V1.1 Comparison function: valid DS function: invalid		
			Type compatible Device V1.1, Backup+Restore	Connected device: V1.1 Comparison function: valid DS function: Valid (Backup & restore)		
			Type compatible Device V1.1, Restore	Connected device: V1.1 Comparison function: valid DS function: valid (for restore only)		
8	PortCycle Time	Setting for communication cycle time with IO-Link device. Ranges (with time increments) in brackets are shown below 0.4-6.3 ms (by 0.1 ms) 6.4-31.6 ms (by 0.4 ms) 32-132.8 ms (by 1.6 ms)	As fast as possible	Automatically set as a minimum cycle time of IO-Link device.	○	Channel
			0.4 to 132.8ms	0.4 to 132.8ms		

•IO-Link master unit parameters (3)

No.	Parameter	Definition	Item	Content	Default setting	Parameter setting range
9	VendorID	Setting for vendor ID which is compared when the IO-Link device comparison function is valid.	0 to 65535	Set the vendor ID of the device to be connected.	0	Channel
10	DeviceID	Setting for device ID which is compared when the IO-Link device comparison function is valid.	0 to 16777215	Set device ID of the device to be connected.	0	Channel

\*1: Refer to "Output setting / IO-LINK communication mode when the PROFINET communication error is generated (page 63)" for difference in operation of the connected device due to settings.

\*2: The availability of the byte swap parameters depends on the process data size of the device to be connected. Refer to I/O byte swap function (page 63) for details.

\*3: Valid only the IO-Link port operation mode is in "Manual".

■ Output setting when the PROFINET communication error occurs. (IO-Link mode)

When a PROFINET communication error occurs, the connected device will operate as follows based on the IO-Link master setting.

IO-Link master setting (Output setting during Communication Fault)		Operation of the connected device
Setting item	Details	
Clear/PD Out valid	All outputs are turned OFF and process data outputs remain valid	Output is cleared.
Hold	Process data outputs remain valid and hold the last data which IO-link master received	Output is held.
Clear/PD Out invalid	All outputs are turned OFF and Process data outputs become invalid	Based on the output setting function when the IO-Link communication error is generated.

■ I/O byte swap function

• Data construction for each setting

The data construction of each parameter for the byte swap function is based on the connected device process data size and the mapping size of the master communication process data as followings.

When the process data size of the connected device and mapping size of the PROFINET master communication process data are matched

(E.g.: connected device process data size: 8-byte, mapping size: 8-byte, 8-byte data value for construction: 0x0123 4567 89AB CDEF)

Parameter	Data construction
direct	0x0123 4567 89AB CDEF
swap 16bit	0x2301 6745 AB89 EFCD
swap 32bit	0x6745 2301 EFCD AB89
swap All	0xEFCD AB89 6745 2301

\*: When the mapping size is 2 byte, even though "swap 32bit" is selected, the byte will not be swapped.

When the process data size of the connected device and mapping size of the PROFINET master communication process data is not matched

(E.g.: connected device process data size: 10-byte, mapping size: 16-byte, 10-byte data value for construction: 0x0123 4567 89AB CDEF GHIJ)

Parameter	Data construction
direct	0x0123 4567 89AB CDEF GHIJ 0000 0000 0000
swap 16bit	0x2301 6745 AB89 EFCD IJGH 0000 0000 0000
swap 32bit	0x6745 2301 EFCD AB89 0000 IJGH 0000 0000
swap All	0x0000 0000 0000 IJGH EFCD AB89 6745 2301

\*: When the mapping size is 2 byte, even though "swap 32bit" is selected, the byte will not be swapped.

\*: When the mapping size of the master connection process data and the process data size of the connected device are different, swap the byte with the blank byte zero.



## ■ Port cycle time setting

The communication cycle time is set automatically or selected from the range of 0.4 ms to 132.8 ms.

Note) The settable minimum cycle time is dependant on the IO-Link device minimum cycle time, communication speed or process data size. The selected port cycle time must be supported by the IO-Link device. The IO-Link master will over-ride an unsupported value and automatically select the minimum cycle time that the IO-Link device can accomodate.

Value	Setting range
As fast as possible	Automatically set to the minimum cycle time of IO-Link device..
0.4 to 6.3ms	The range from 0.4 to 6.3ms can be set in 0.1ms increments.
6.4 to 31.6ms	The range from 6.4 to 31.6ms can be set in 0.4ms increments.
32.0 to 132.8ms	The range from 32.0 to 132.8ms can be set in 1.6ms increments.

## ■ Data storage function

The data storage function is available when the  
 -IO-Link port operation mode is "Manual" and  
 -Validation & Backup is "Type compatible, Device V1.1, Backup + Restore" or "Type compatible, Device V1.1, Restore".

### • Outline of backup and restore

The parameter setting data for each IO-Link device can be stored (referred to as "backup") in the IO-Link master.

When the IO-Link device is replaced by another identical device, the backup parameters in the IO-Link master can be transferred to the replacement IO-Link device (referred to as "restore").

### • Condition of the backup / restore operation when the IO-Link communication starts up

The data storage operation will be as follows based on the Data storage status of the IO-Link master and whether the IO-link device parameters have been changed.

Validation & Backup set value	Condition			Data storage operation
	Data storage status	Backup requirement from the device	Checksum of the data storage and device parameter	
No Device Check	-	-	-	Cleared
Type compatible, Device V1.0	-	-	-	Cleared
Type compatible, Device V1.1	-	-	-	Cleared
Type compatible, Device V1.1, Backup + Restore	Data exists	Required	-	Backup
	Data exists	No requirement	Not identical	Restore
	Data exists	Required	Identical	Nothing occurs
	No data	-	-	Backup
Type compatible, Device V1.1, Restore	Data exists	-	Not identical	Restore
	Data exists	-	Identical	Nothing occurs
	No data	-	-	Nothing occurs

Note 1) When the vendor ID or device ID are changed, the data storage will be cleared.

Note 2) When the IO-Link port operation mode is changed to a setting other than "Manual", Validation & Backup values are automatically changed to "No Device Check". Therefore, the data storage will be cleared.

## I/O Map

Allocated EX600 input and output bytes for each unit type

Allocated input and output size are changable according to the diagnosis setting and connected EX600 unit type. The allocated input and output bytes for each EX600 unit are shown below.

Unit	Unit part number	Allocated bytes	
		Input	Output
SI unit	EX600-SPN3 / 4 (32 outputs)	0	4
	EX600-SPN3 / 4 (32 outputs) (with diagnostic data)	4	4
Digital input unit	EX600-DX#B (8 inputs)	1	0
	EX600-DX#C (8 inputs)	1	0
	EX600-DX#C1 (8 inputs) (with open circuit detection)	1	0
	EX600-DX#D (16 inputs)	2	0
	EX600-DX#E (16 inputs)	2	0
	EX600-DX#F (16 inputs)	2	0
Digital output unit	EX600-DY#B (8 outputs)	0	1
	EX600-DY#E (16 outputs)	0	2
	EX600-DY#F (16 outputs)	0	2
	EX600-DYPE1 (24 outputs)	0	3
	EX600-DYPG1 (4 outputs)	0	1
Digital I/O unit	EX600-DM#E (8 inputs/8 outputs)	1	1
	EX600-DM#F (8 inputs/8 outputs)	1	1

Unit	Unit part number	Allocated bytes	
		Input	Output
Analogue input Unit	EX600-AXA (2 channels)	4 (2 bytes per channel)	0
	EX600-AXB (4 channels)	8 (2 bytes per channel)	0
Analogue output Unit	EX600-AYA (2 channels)	0	4 (2 bytes per channel)
Analogue I/O Unit	EX600-AMB (2/2 channels)	4 (2 bytes per channel)	4 (2 bytes per channel)
IO-Link master Class A	EX600-LAB1 (4 ports)	6 to 134 byte (Max.32byte per port)	6 to 134 byte (Max.32byte per port)
IO-Link master Class B	EX600-LBB1 (4 ports)	6 to 134 byte (Max.32byte per port)	6 to 134 byte (Max.32byte per port)

■ Details of I/O map of the IO-Link master unit

I/O map of standard IO and PQI are described below. ( Identical to EX600-LAB1 and EX600-LBB1)

Standard IO

	Input								Output							
	Bit 7				Bit 0				Bit 7				Bit 0			
Byte N	X2	X4	X2	X4	X2	X4	X2	X4	-	Y4	-	Y4	-	Y4	-	Y4
	Port 4		Port 3		Port 2		Port 1		Port 4		Port 3		Port 2		Port 1	
Byte N+1	Reserved (fixed value: 0)								Reserved (fixed value: 0)							

\*: X2: Input signal of Pin No.2. (EX600-LAB1 only)

X4: Input signal of Pin No.4 when the IO-Link port operation mode is set to digital input mode (DI\_C/Q)

Y4: Output signal of Pin No.4 when the IO-Link port operation mode is set to digital output mode (DO\_C/Q)

PQI

	Input				Output			
	Bit 7		Bit 0		Bit 7		Bit 0	
Byte M	Port 1 status (PQI)				Reserved (fixed value: 0)			
Byte M+1	Port 2 status (PQI)				Reserved (fixed value: 0)			
Byte M+2	Port 3 status (PQI)				Reserved (fixed value: 0)			
Byte M+3	Port 4 status (PQI)				Reserved (fixed value: 0)			

•Port status (PQI) details

	Bit 7	Bit 6	Bit 5	Bit 4	Bit 3	Bit 2	Bit 1	Bit 0
Byte n	PQ	Dev-Err	Dev-Com	DSSstatus	CQ-Short	Pwr-Short	PDmapping-Mismatch	ID-Mismatch

Bit	Description	Details	Value
0	ID-Mismatch	Connection device matching error	0: Match 1: Mismatch
1	Pdmapping-Mismatch	Process data mapping size error*1	0: Set size or less 1: Exceeding size
2	PwrShort	L+ short circuit or P24 short circuit	0: No short circuit 1: Short circuited
3	CQShort	C/Q short circuit	0: No short circuit 1: Short circuited
4	DSSstatus	Data storage (DS) save status	0: DS saved data error, no DS data 1: DS saved data is valid
5	DevCom	Port communication status	0: Device not connected 1: Operate or Preoperate
6	DevErr	Event status (Device or master event status)	0: No event or notification 1: Warning or Error
7	PQ	Received input process data Valid (normal) / invalid (abnormal)*2	0: Invalid (abnormal) 1: Valid (normal)

\*1: An error is detected when the process data size of the actually connected device exceeds the size which is set in the process data mapping.

\*2: Process data is held when the received input process data is abnormal (Process Data Invalid).

# Diagnosis

4 bytes of diagnostic information can be assigned to the input by selecting “EX600-SPN# (32 coils, Status)” when adding the SI unit in the hardware configuration.

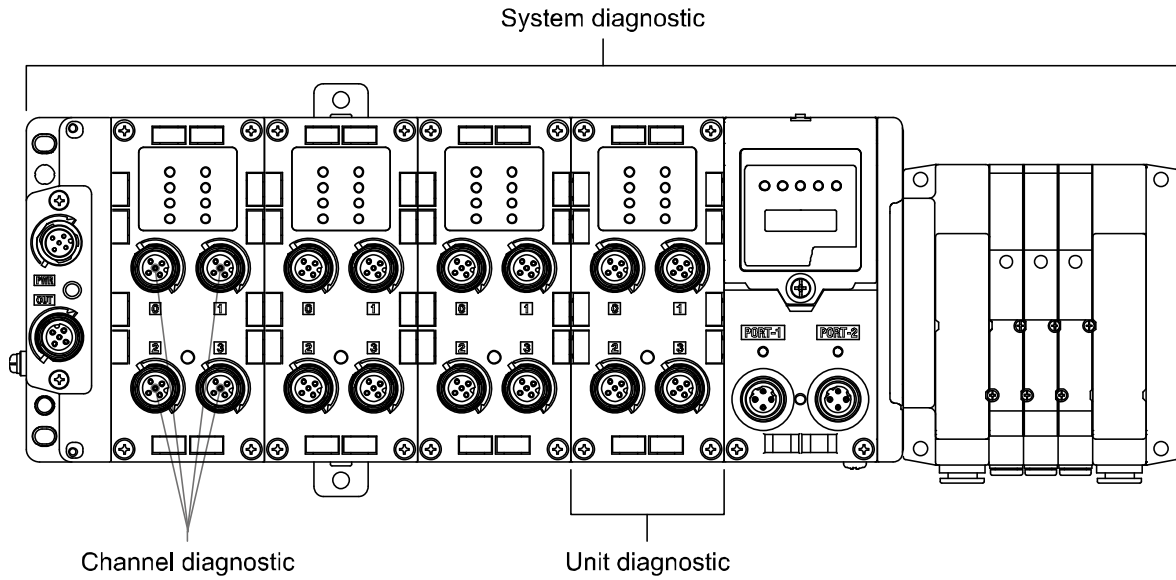

•Diagnostics map

Byte No.	Diagnostics name	Diagnostics type
Byte 0	System diagnostic status 0	System diagnostic
Byte 1	System diagnostic status 1	
Byte 2	Unit diagnostic status 0	Unit diagnostic
Byte 3	Unit diagnostic status 1	

## ■Details of diagnostic data

### Diagnostic data

Byte	Bit No.	Diagnostic content
0	0	The analogue input or output value has fallen below the user set value.
	1	The analogue input or output value has exceeded the user set value.
	2	The analogue input value has fallen below the setting range.
	3	The analogue input value has exceeded the setting range.
	4	The ON/OFF counter has exceeded the set value.
	5	The open circuit has been detected.
	6	The short circuit of the valve output or digital output has been detected.
	7	The short circuit of the power supply for the input device has been detected.
1	0	The power supply voltage for output device is outside of the specification.
	1	The power supply voltage for control and input device is outside of the specification.
	2	Reserved
	3	There is a connection failure between each unit (During operation).
	4	There is a connection failure between each unit (When the power supply is applied).
	5	Reserved
	6	System error occurred.
	7	Hardware error occurred.
2	0	There is an error in unit 0.
	1	There is an error in unit 1.
	2	There is an error in unit 2.
	3	There is an error in unit 3.
	4	There is an error in unit 4.
	5	There is an error in unit 5.
	6	There is an error in unit 6.
	7	There is an error in unit 7.
3	0	There is an error in unit 8.
	1	There is an error in unit 9.
	2	Reserved
	3	Reserved
	4	Reserved
	5	Reserved
	6	Reserved
	7	Reserved

\*: The data of diagnostic content: "0" means No error and "1" means Error.

•Channel diagnostic information

The following is the procedure to confirm on-line diagnostics using the Siemens TIA PORTAL.

- (1) Select the “EX600-SPN [EX600-SPN3/SPN4]” from Project tree. The "Device overview" window will be displayed.
- (2) Press “Go online” button.
- (3) The unit with the diagnostic error is displayed in red.
- (4) By double-clicking, the contents of the channel diagnosis error will be displayed

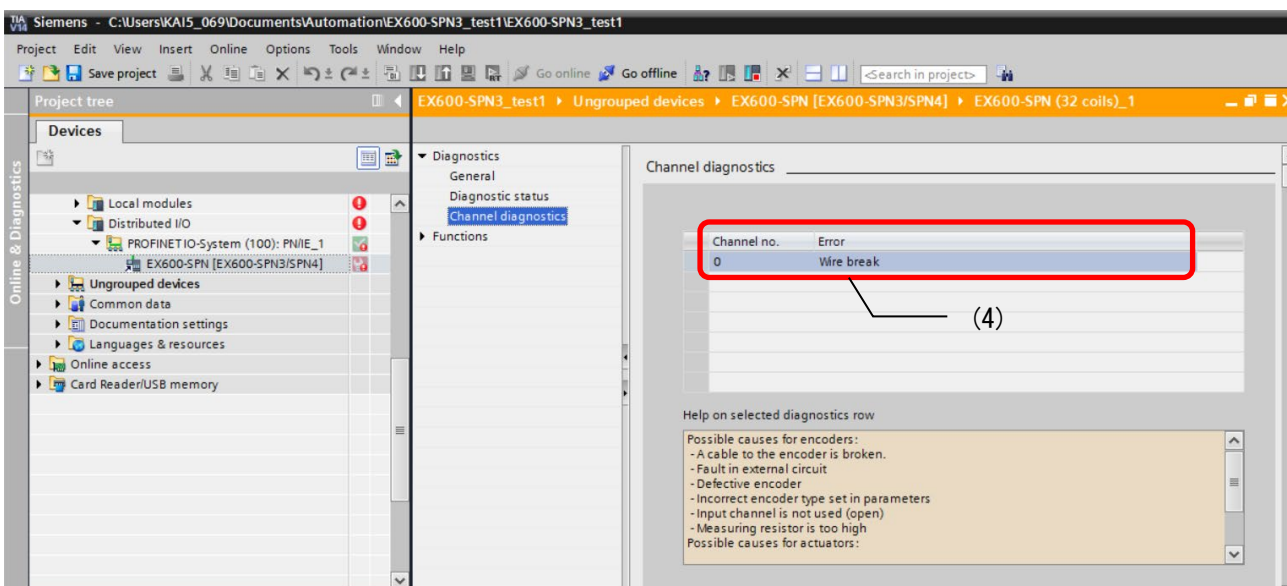
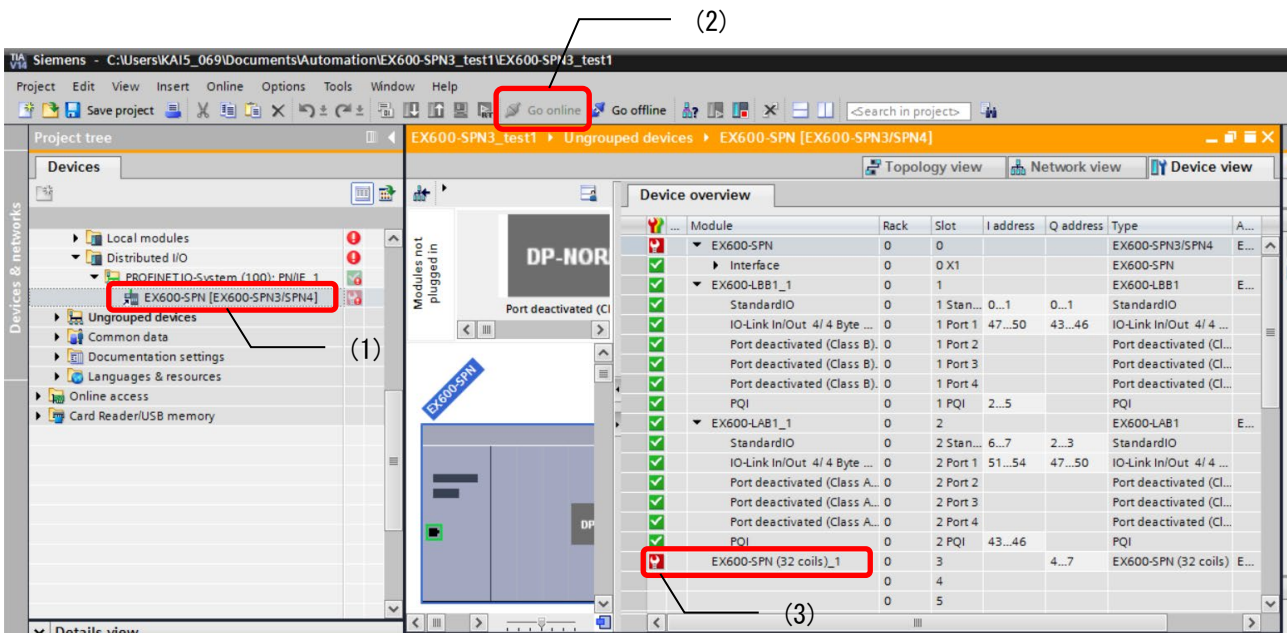



## ■Diagnosis of IO-Link master unit data

The EX600 IO-Link master unit has a diagnostic function for each port. The diagnostics are shown via the LED display and process data input (PQI) in accordance with the diagnostic contents. The details of LED display, PQI and event code for each diagnostic are shown below.

Port diagnostics function	Details	Port LED status	PQI Bit No. (Description)	Event code
L+ short circuit detection	Pin No. 1-3 short circuit diagnostics	Red ON	2 (PwrShort)	0x1806
P24 short circuit detection	Pin No. 2-5 short circuit diagnostics	Red ON	2 (PwrShort)	0x180F
C/Q short circuit	Pin No. 1-4 or 3-4 short circuit diagnostics	Red ON	3 (CQShort)	0x1804 0x1813
Connected device matching error	Dagnositics are available when -the port operation mode is IO-Link and -the communication port is set as "Type Compatible". If the detected Vendor ID and Device ID are not matched with registerd values, an error is diagnosed.	Green flashing	0 (ID Mismatch)	0x1803
Device process data mapping error *1	If connected device has longer process data than mapped data, an error will be diagnosed. This diagnostic is valid during port operation mode is IO-Link.	Green flashing	1 (PDmapping-Mismatch)	0x1F01
Device disconnection is detected *2	When the pin function / operation mode is set to IO-Link, device disconnection is detected.	Green flashing	5 (DevCom)	0x1800
P24 power supply reduction	Power supply reduction of class B type Pin No. 2-5 is diagnosed.	OFF (P24)	-	0x180E

\*1: Under the mapping error, all of the process data input and output are zero.

\*2: When the port is not connected to devices, all of the input process data will be zero.

Note) Diagnostics other than the short circuit detection (L+, P24, C/Q) are not handled as the EX600 diagnostic data, so check for the LED display and PQI of the IO-Link master.

## Hardware Configuration

### ■GSDML file and icons

A GSDML file is required to configure the EX600 with the PLC. At the same time, a special icon is required to display the icon for EX600 in the software of the PLC.

The GSDML and icon files can be downloaded from the following URL.

- URL : <http://www.smcworld.com>
- GSDML file: GSDML-V2.35-SMC-EX600-\*\*\*.xml
- Icon file: GSDML-0083-0008-EX600\_N.bmp

### ■Configuration layout

The unit numbers of the EX600 are assigned as following, assigned Unit 0 from the end plate side. The physical order must match the logical order as defined in the program hardware configuration otherwise communication with the PLC will not be possible

- Unit number example

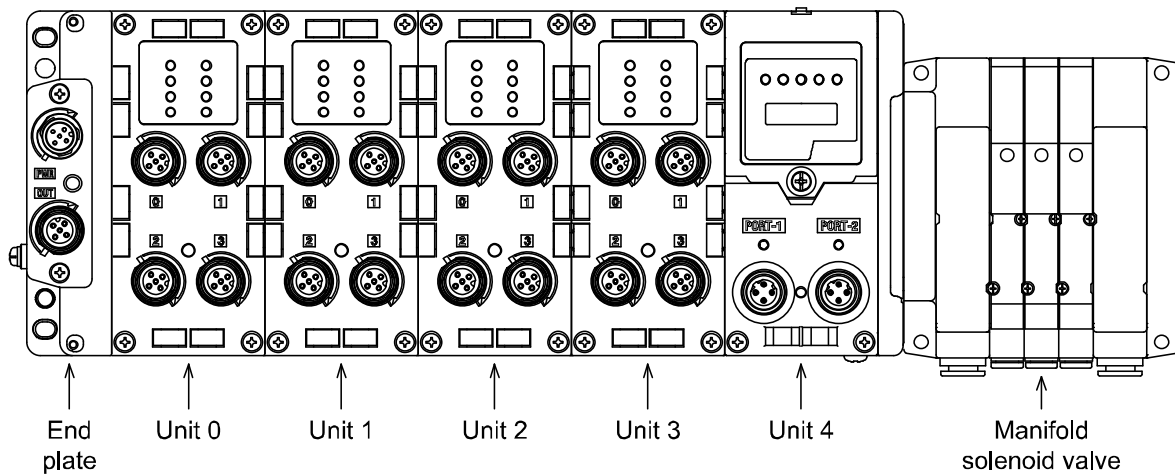

## ■ Connection to SIEMENS PLC

How to connect the EX600 series to SIEMENS PLC is explained below.

Refer to the Operation Manual of the SIEMENS PLC for the detailed operation.

\*: The drawing below shows the SIEMENS software, TIA PORTAL V14

### 1. GSDML file installation

- (1) Select “Options” → “Manage general station description files (GSD)” from menu bar.
- (2) “Manage general station description file” window will be displayed. Select the folder in which the GSDML file is stored.
- (3) A list of stored GSDML files will be displayed. Select the file to install, and press “Install”.
- (4) EX600-SPN# hardware component will be added to “Hardware Catalog” window folder.  
(PROFINET IO / Additional Field Devices / Valves / SMC EX600 / EX600-SPN3/SPN4)

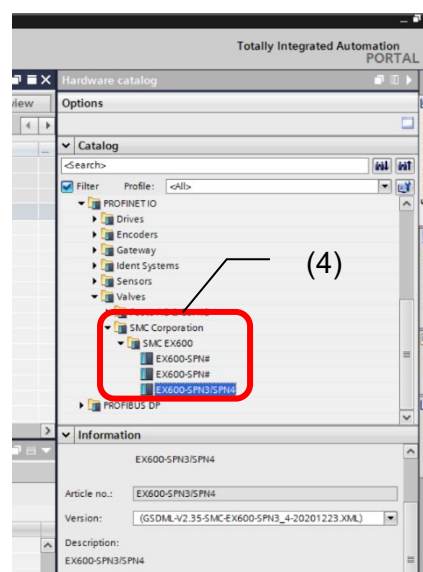
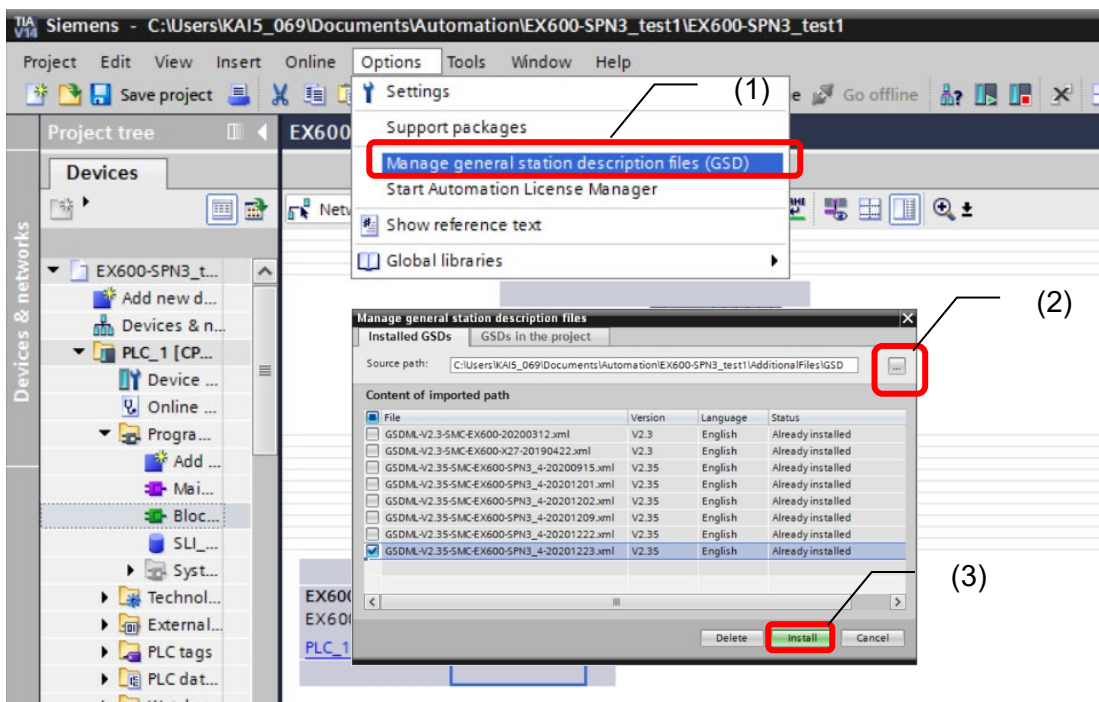

## 2. Addition of EX600-SPN3/SPN4

- (1) Select "EX600-SPN3 / SPN4" from "Hardware catalog" and drag and drop it on the "Devices & networks" screen.
- (2) Connect the PLC and EX600-SPN3 / SPN4.

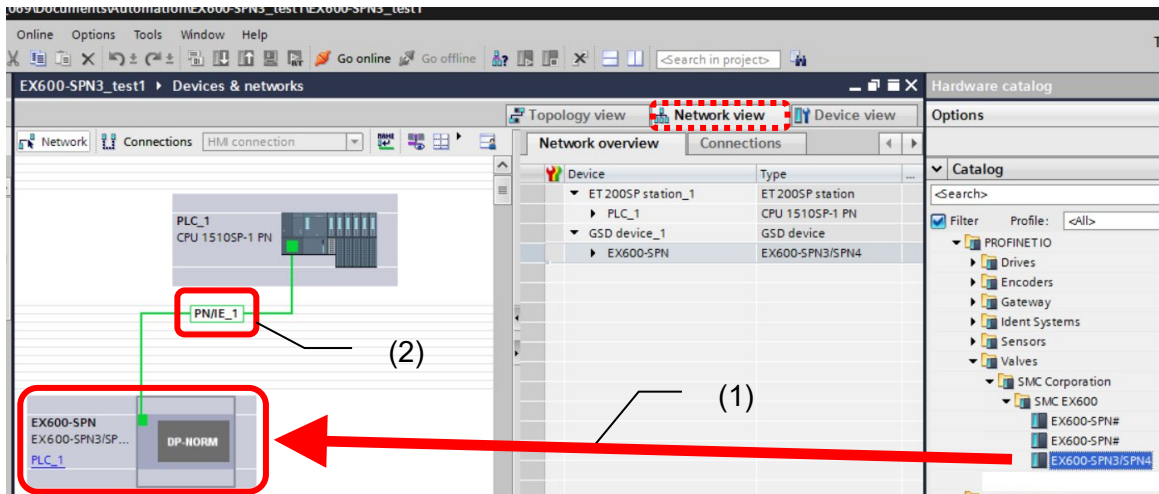

### 3. Addition of the IO unit

- (1) Select "EX600-SPN3 / SPN4" from "Hardware catalog" and drag and drop it on the "Devices & networks" screen.
- (2) From the "Hardware catalog" window, select the module product number that matches unit 0 and drag and drop it onto Slot 1 on the "Device overview" screen.
- (3) Drag and drop the other slots in the same way.
  - The module product number of Unit0 → Slot1
  - The module product number of Unit1 → Slot2
  - The module product number of Unit2 → Slot3
  - ⋮
  - The module product number of Unit8 → Slot9
  - The module product number of Unit9 → Slot10

(4) The initial (default) port setting of the IO-Link master unit is Port deactivated. To change the settings, first delete "Port deactivated" on the "Device overview" screen, then select a function from Submodules in the "Hardware catalog" and drag and drop it onto slot.

- (5) The last slot must be the SI unit.
  - Two types of SI units can be selected (Note: an SI unit cannot be assigned to multiple slots).
  - Type1: EX600-SPN (32 coils) --- Occupies 4 bytes for output (No diagnostic data)
  - Type2: EX600-SPN (32 coils, Status) --- Occupies 4 bytes for output and 4 bytes for diagnostics (input)

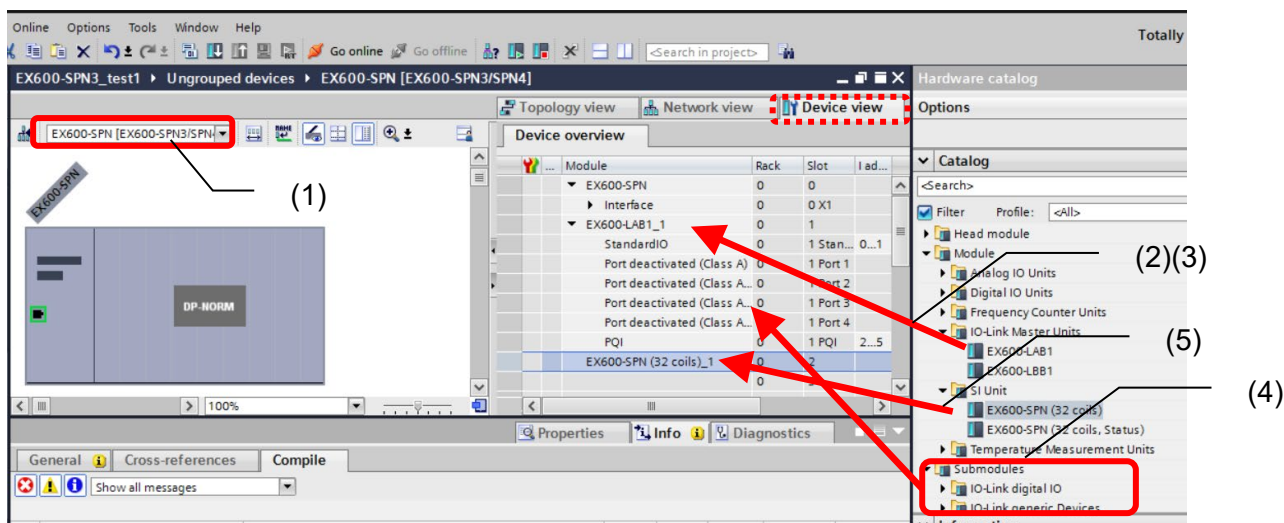

#### 4. Write Device Name to EX600

- (1) Connect the EX600 and PLC with a PROFINET communication cable.
- (2) Select "Network view" tab → "Properties" tab of EX600.
- (3) Write the PROFINET device name.
- (4) Press the "Download to device" icon.

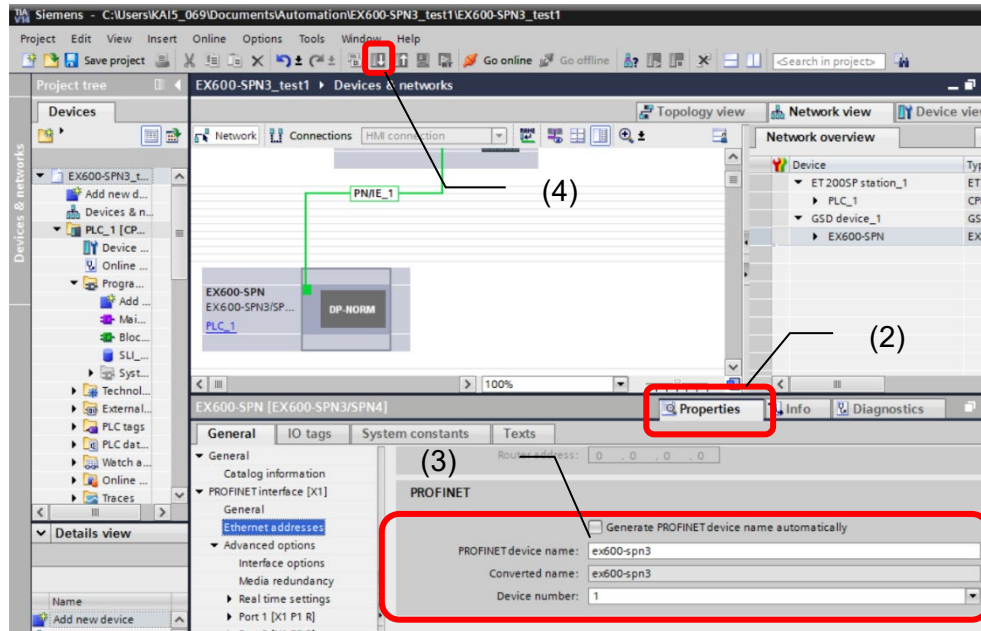

## 5. Device Name assignment

- (1) Select EX600 on the “Network view” tab, right-click the mouse and select “Assign device name”.

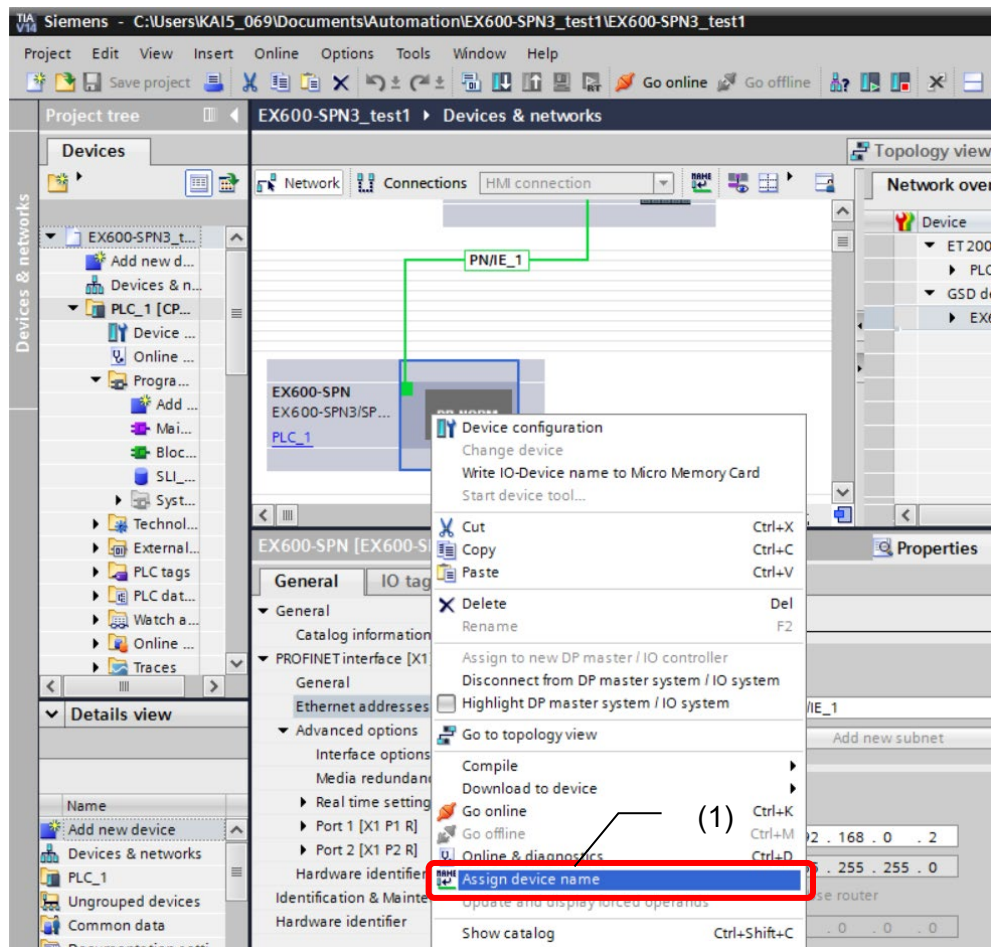



- (2) Press "Update list" to update "Assign PROFINET device name" window.
- (3) Connected SI unit on the network will be displayed in "Accessible devices in the network".
- (4) Press "Assign name" to complete the configuration.

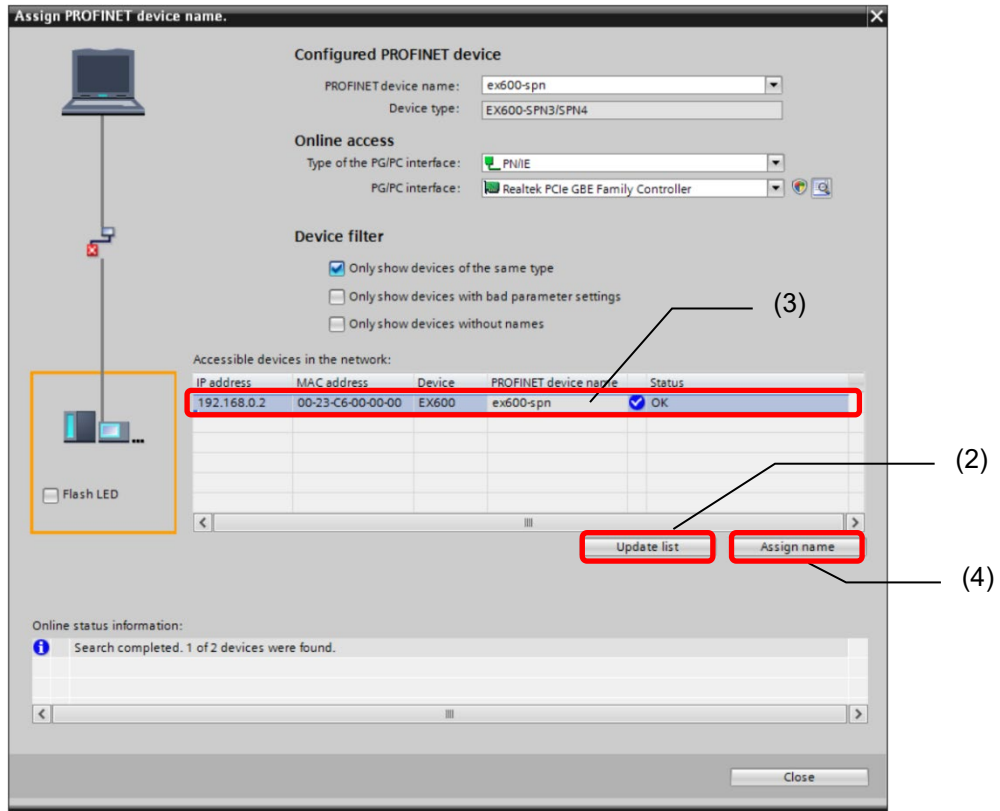



## 6.Parameter setting

- Setting of EX600 Module parameters

- (1) Select EX600-SPN on the „Device view“ tab.
- (2) Select the Module or Submodule that requires parameter changes in the “Device overview”.
- (3) Select “Properties” tab → ”General” tab and select ”Module parameters” to display a list of parameters that can be set.
- (4) Select the parameter and change the value.
- (5) Press the “Download to device” icon.

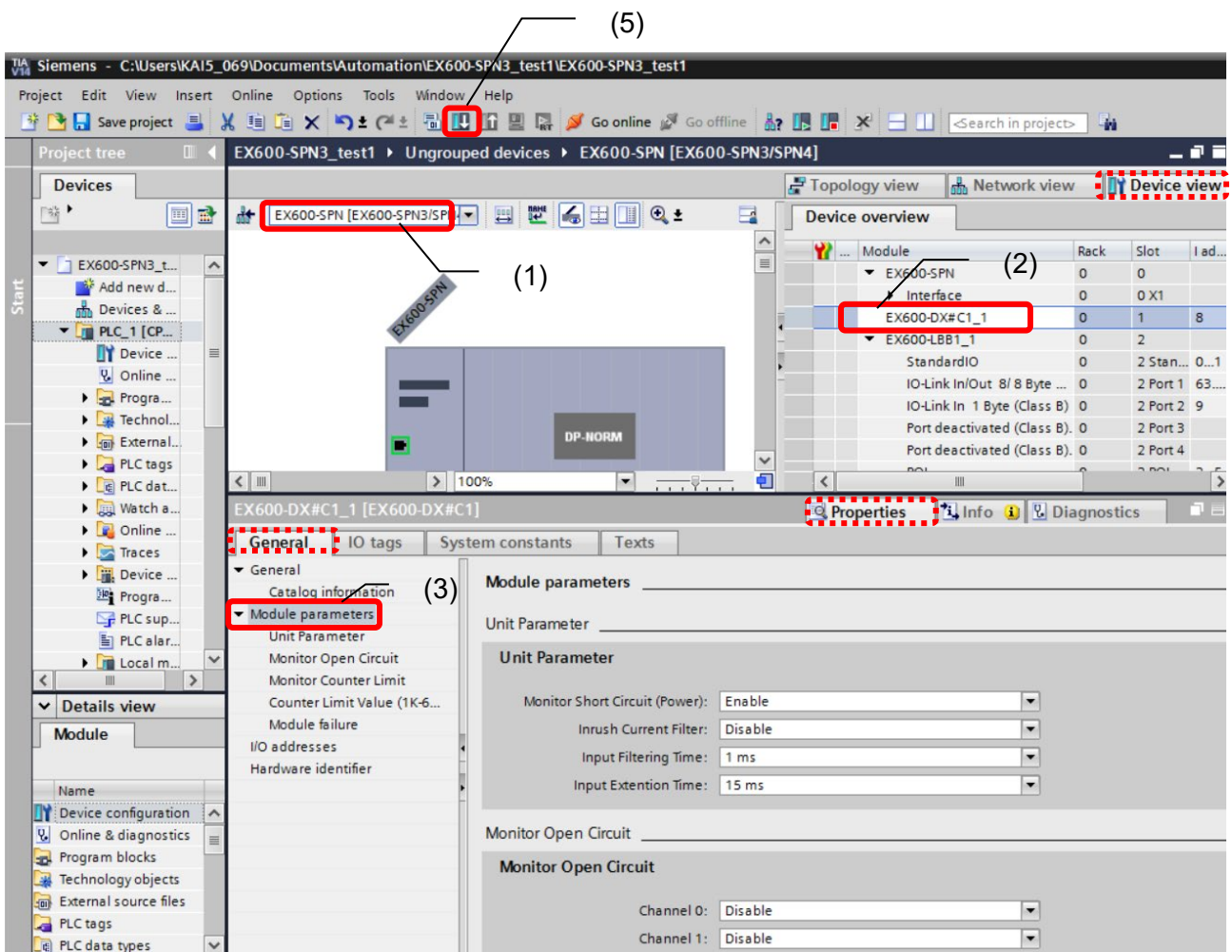

■ Setting of Fast startup (FSU)

EX600 implements the Fast startup function.

To use the Fast startup function, the EX600 and PLC configuration must be changed.

[PLC settings]

- (1) Select PLC on the "Device view" tab.
- (2) Select the communication port to set for the Fast Start Up and select "Properties" tab → "General" tab → "Port options".
- (3) Set "Transmission rate / duplex" to "TP 100 Mbps full duplex" and uncheck "Enable autonegotiation".
- (4) Press the "Download to device" icon.

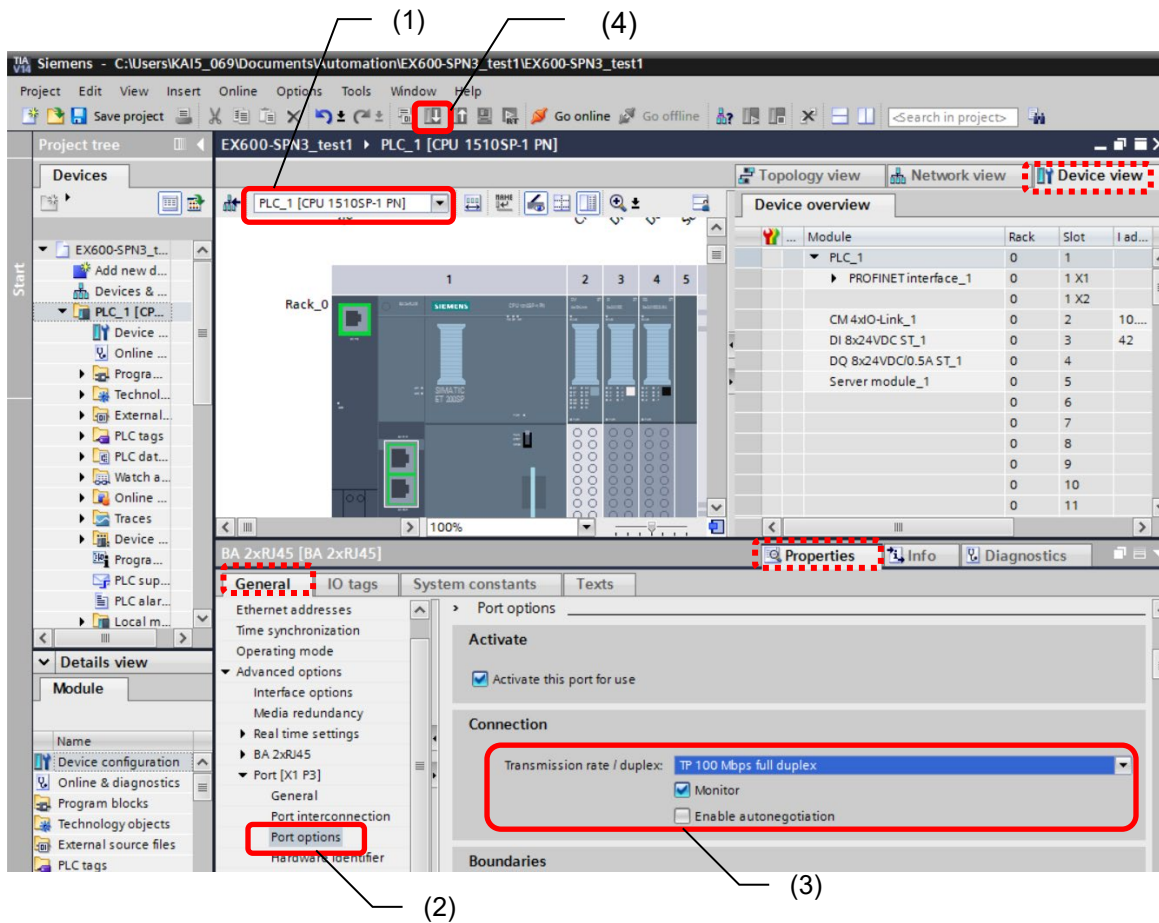

[EX600 settings]

- (1) Select EX600-SPN on the "Device view" tab.
- (2) Select the communication port to set for the Fast Start Up and select "Properties" tab → "General" tab → "Port options".
- (3) Set "Transmission rate / duplex" to "TP 100 Mbps full duplex" and uncheck "Enable autonegotiation".

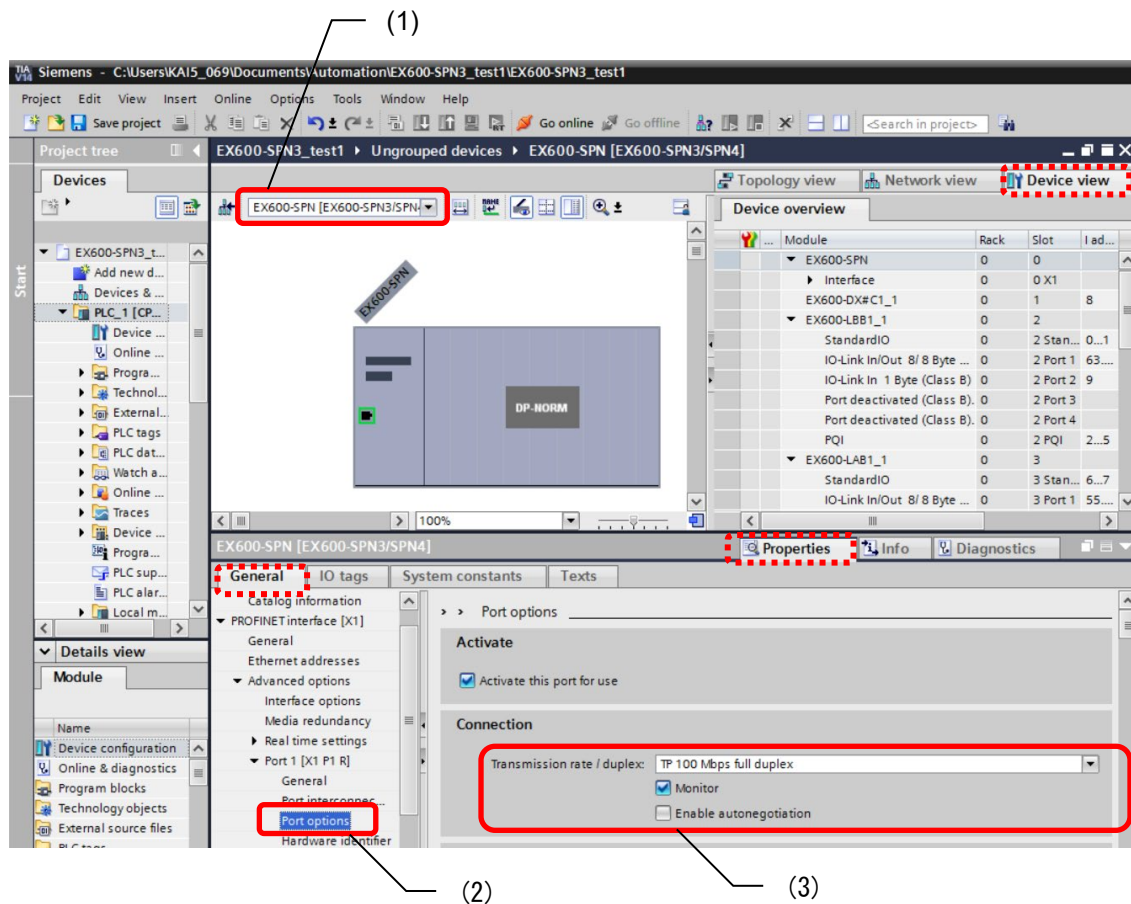

(2)

(3)

- (4) Check "Prioritized startup" in the Interface options.
- (5) Press the "Download to device" icon.

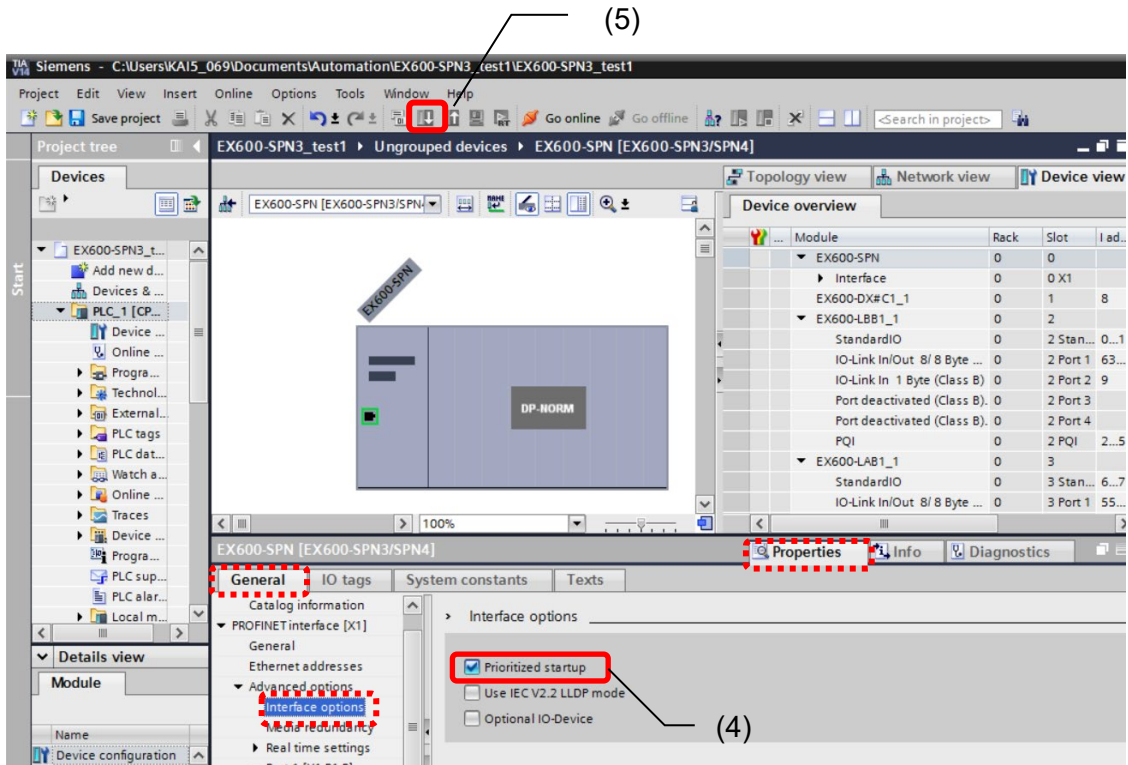

## Web Server

### EX600 Web server functional overview

The Web server function is provided by the EX600-SPN3 / SPN4.

The functions available vary depending on the mode.

Function	Admin mode	Monitor only mode
I/O Monitor	Available	Available
Diagnostic status monitor	Available	Available
Parameter setting	Not available	Not available
Force I/O setting	Available	Not available

The web browsers that have been confirmed to work correctly are as shown in the table below.

Web browser	Version
Google Chrome	Ver.85
Mozilla firefox	Ver.81
Microsoft Edge(Chromium)	Ver.85

\*Internet Explorer is not supported.

#### NOTE

Web server functionality may not work correctly with browsers other than those in the above table.

**Connecting to EX600-SPN3** (Ex. IP address of EX600-SPN3 is 192.168.0.1.)

- (1) Connect PC and EX600-SPN3 with a communication cable and open the web browser.
- (2) Match the top 3 octets of IP address between PC and EX600.  
Ex. PC IP address 192.168.0.250 (subnet mask 255.255.255.0)
- (3) Type the IP address of EX600-SPN3 on the web browser. (Ex. http://192.168.0.1)  
The EX600 webpage should load after several seconds.

**NOTE**

Connect one SI unit to one PC.

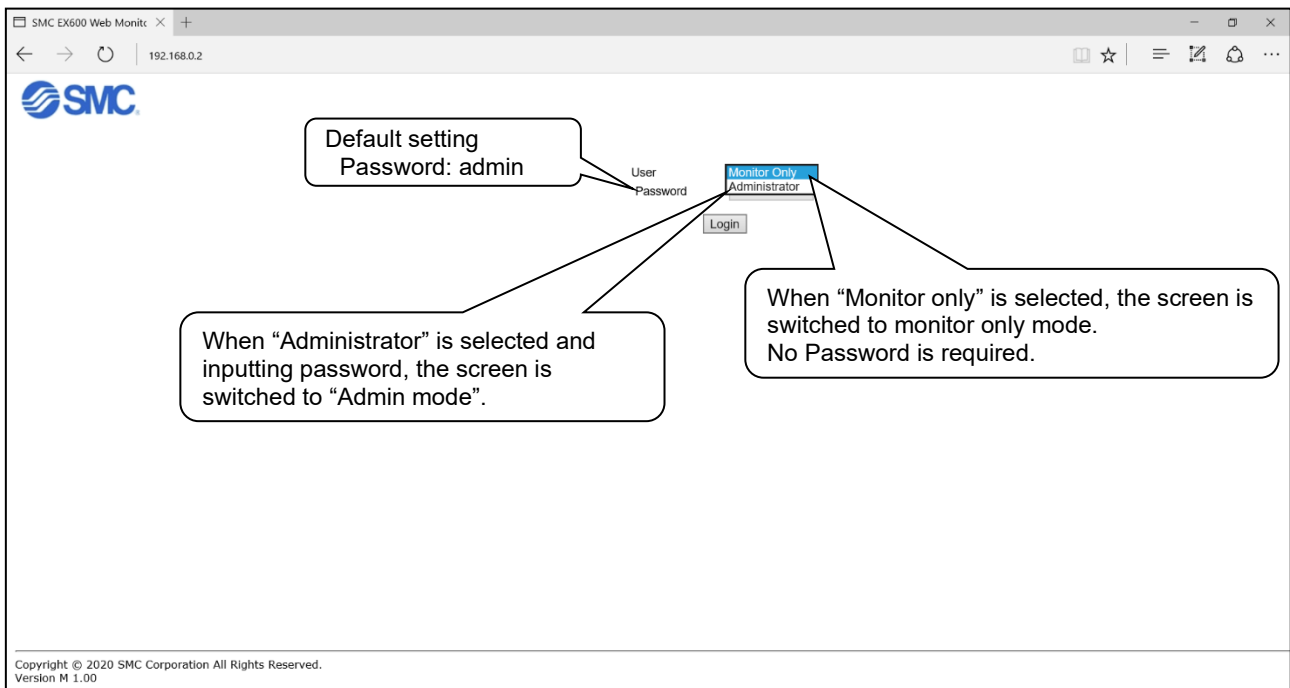

4) After pressing the "Login" button, the "SYSTEM CONFIGURATION STATUS" web page is displayed. This page is the TOP (or main) web page of the EX600 webserver

Web server communication status is displayed.

Click here to logout.

Click "Unit name" to display the I/O Monitor.

The total size of input/output is displayed.

Click here to change the password.

Click here to clear error log.

SYSTEM CONFIGURATION STATUS

Unit	Unit No.	Unit Type	Input Size	Output Size	Diagnostic Status	Force Check
0	EX600-DX#C1	8DI	1 byte	0 byte	-	-
1	EX600-DX#C1	8DI	1 byte	0 byte	-	-
2	EX600-LBB1	4IOL	16 byte	10 byte	-	-
3	EX600-LAB1	4IOL	16 byte	10 byte	-	-
4	EX600-SPN#	32DO	0 byte	4 byte	-	-
5	-	-	-	-	-	-
6	-	-	-	-	-	-
7	-	-	-	-	-	-
8	-	-	-	-	-	-
9	-	-	-	-	-	-

SYSTEM DIAGNOSTIC INFORMATION

STATUS LOG

Copyright © 2020 SMC Corporation All Rights Reserved. Version M 1.00

**NOTE**  
The screen above shows the case when the manifold hardware configuration is as shown below

Configuration

	No.0	No.1	No.2	No.3	No.4	No.5	No.6	No.7	No.8	No.9
End plate	EX600-DX#C1	EX600-DX#C1	EX600-LBB1	EX600-LAB1	EX600-SPN3					

(5) When unit diagnosis is detected, the diagnostic information is displayed on the “SYSTEM CONFIGURATION STATUS” screen.

The screenshot shows the SMC EX600 Web Monitor interface. The browser address bar displays '192.168.0.2/toppage.html'. The SMC logo is in the top left. On the left side, there are navigation links: 'TOP', 'LOGOUT', 'CHANGE PASSWORD', and 'MAINTENANCE'. The main content area is divided into two sections: 'SYSTEM CONFIGURATION STATUS' and 'SYSTEM DIAGNOSTIC INFORMATION'.

**SYSTEM CONFIGURATION STATUS**

Total Input Size: 26 byte, Total Output Size: 16 byte

Unit	Unit Name	Unit Type	Input Size	Output Size	Diagnostic Status	Force Check
0	EX600-DX#C1	8DI	1 byte	0 byte	ERROR	-
1	EX600-DX#C1	8DI	1 byte	0 byte	-	-
2	EX600-LBB1	4IOL	12 byte	6 byte	-	-
3	EX600-LAB1	4IOL	12 byte	6 byte	-	-
4	EX600-SPN#	32DO	0 byte	4 byte	-	-
5	-	-	-	-	-	-
6	-	-	-	-	-	-
7	-	-	-	-	-	-
8	-	-	-	-	-	-
9	-	-	-	-	-	-

**SYSTEM DIAGNOSTIC INFORMATION**

STATUS LOG

No.	Time	Unit	Ch	Description
1	0:32:51	0	0	Short circuit
2	-	-	-	-
3	-	-	-	-
4	-	-	-	-
5	-	-	-	-
6	-	-	-	-

Copyright © 2020 SMC Corporation All Rights Reserved. Version M 1.00

Identifies the unit that detected the diagnosis.

Select “LOG” tab to display the error log information.



(6) When “Unit Name” is selected (i.e.left mouse button double clicked) on the “SYSTEM CONFIGURATION STATUS” screen, the “I/O MONITOR” screen is displayed. (EX. EX600-DX□C1)

Unit.0 EX600-DX#C1 8DI  
I/O MONITOR

CH	ON/OFF	Diagnostic Status
IN0	ON	-
IN1	OFF	-
IN2	OFF	-
IN3	OFF	-
IN4	OFF	-
IN5	OFF	-
IN6	OFF	-
IN7	OFF	-

ON/OFF information can be monitored for each channel.

Unit.0 EX600-DX#C1 8DI  
I/O MONITOR

CH	ON/OFF	Diagnostic Status
IN0	OFF	Short circuit
IN1	OFF	-
IN2	OFF	-
IN3	OFF	-
IN4	OFF	-
IN5	OFF	-
IN6	OFF	-
IN7	OFF	-

If the diagnostic is detected, diagnostic information will be displayed.

- (7) Select "UNIT PARAMETER" tab to display "UNIT PARAMETER" screen.  
The unit parameters are read-only.

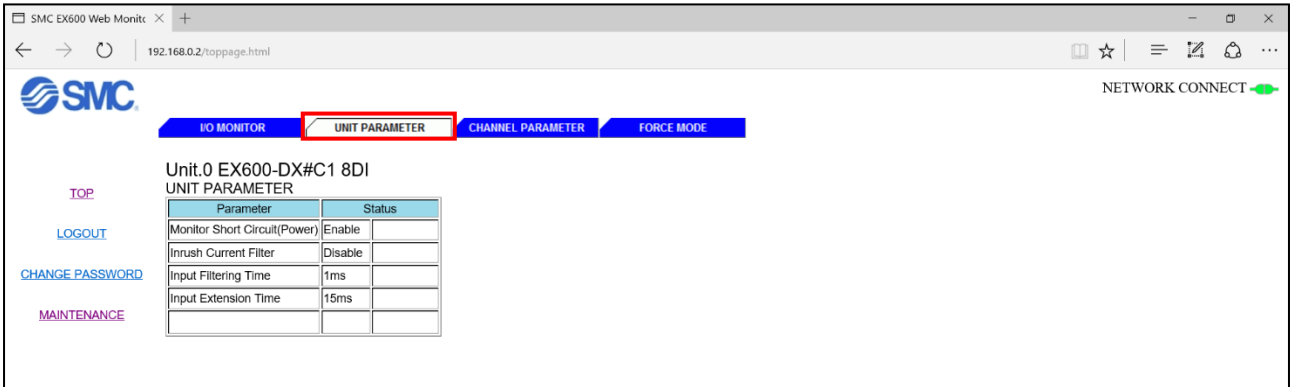

- (8) Select "CHANNEL PARAMETER" tab to display "CHANNEL PARAMETER" screen.  
In the channel parameter, the ON/OFF counter value can be cleared to 0.

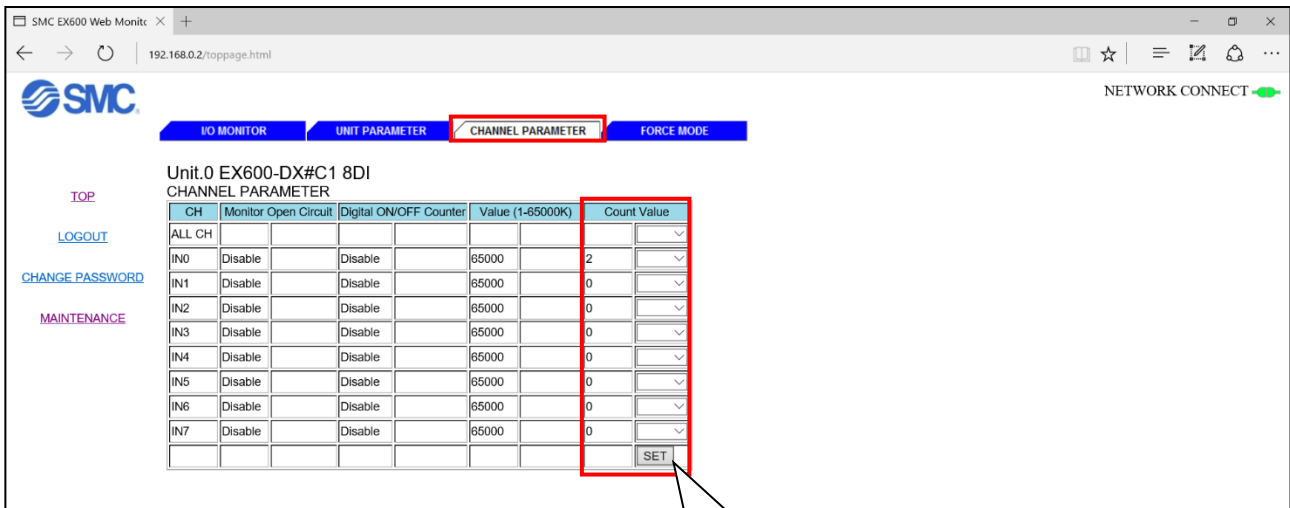

Select "Clear" and press "SET" to clear the counter value to 0.

(9) Select "FORCE MODE" tab to display below screen.

Unit.0 EX600-DX#C1 8DI  
CHANNEL PARAMETER

CH	Monitor Open Circuit	Digital ON/OFF Counter	Value (1-65000K)	Count Value
ALL CH				
IN0	Disable	Disable	65000	2
IN1	Disable	Disable		
IN2	Disable	Disable		
IN3	Disable	Disable		
IN4	Disable	Disable		
IN5	Disable	Disable		
IN6	Disable	Disable		
IN7	Disable	Disable		

サイトからのメッセージ  
Forced I/O setting should be executed after confirming the safety of the device.  
Go to FORCE MODE?  
OK キャンセル

After checking the safety of the surrounding and equipment, press "OK".

## Warning

- The forced input/output function is used to change the signal status forcibly. When operating this function, be sure to check the safety of the surrounding and equipment. Otherwise, injury or equipment damage could result.

(10) Tick the check box on the "FORCE MODE" screen to enable forced mode.

Unit.0 EX600-DX#C1 8DI  
FORCE MODE

Check the box to enable forced mode. If the device is not safe, don't change the setting.

CH	ON/OFF	Force Mode		
		ALL ON	ALL OFF	ALL RESET
ALL CH				
IN0	ON	ON	OFF	RESET
IN1	ON	ON	OFF	RESET
IN2	ON	ON	OFF	RESET
IN3	ON	ON	OFF	RESET
IN4	ON	ON	OFF	RESET
IN5	ON	ON	OFF	RESET
IN6	ON	ON	OFF	RESET
IN7	ON	ON	OFF	RESET

Check box

Force mode status is displayed.

Forced ON Forced OFF Release forced mode

### NOTE

There are two ways to cancel the forced mode: "press the RESET button" or "LOG OUT from the Web server".

Please note that if the forced mode is canceled while PROFINET communication with the PLC is established, the input / output data with the PLC will be shown immediately.

(11) To change the Password, log in using Administrator mode and select "CHANGE PASSWORD".

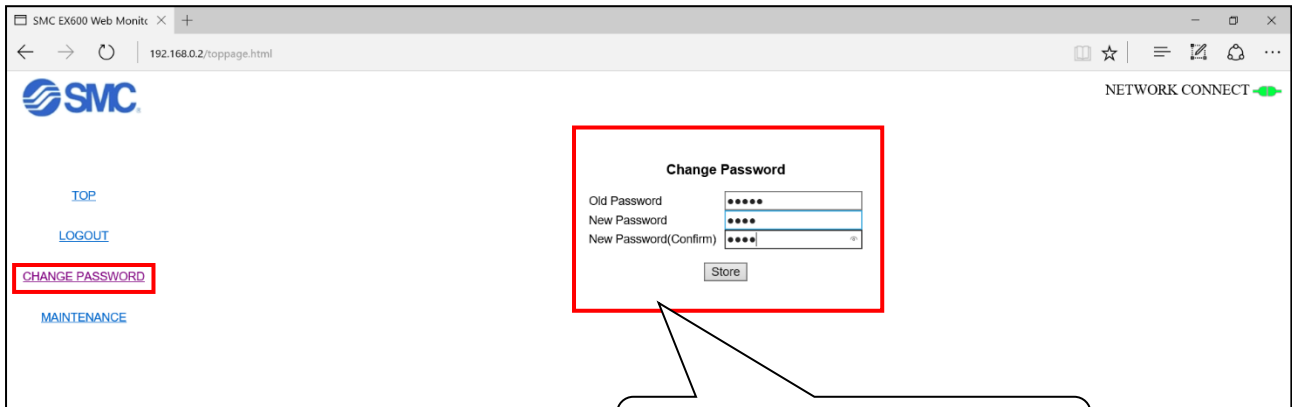

After entering the Old Password and New Password, press "Store" to change the password.

(12) To clear the Error Log, log in using Administrator mode and select "MAINTENANCE".

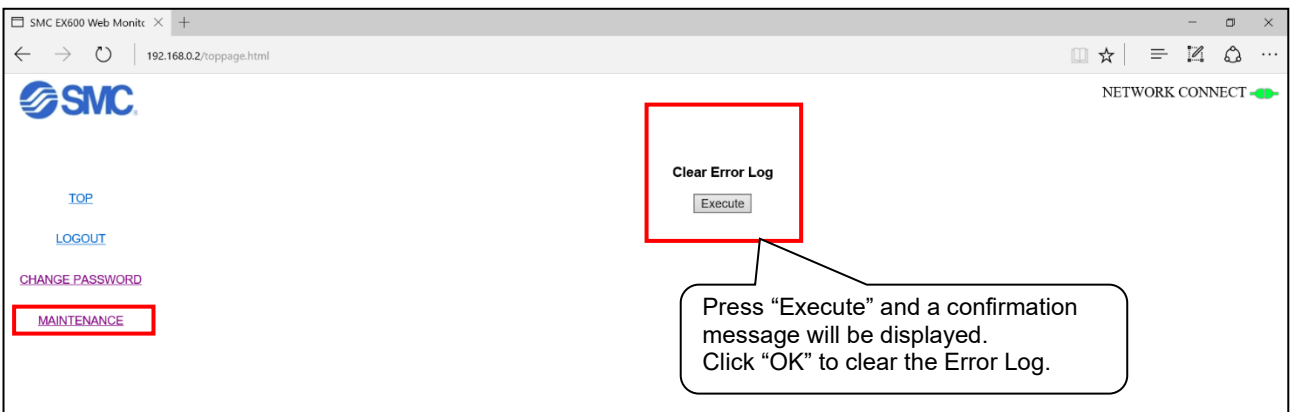

Press "Execute" and a confirmation message will be displayed. Click "OK" to clear the Error Log.

## Accessories

For the selection of accessories, refer to the catalog.

### (1) Valve plate

EX600-ZMV1

Enclosed parts: Round head screw (M4 x 6), 2 pcs.  
Round head screw (M3 x 8), 4 pcs.

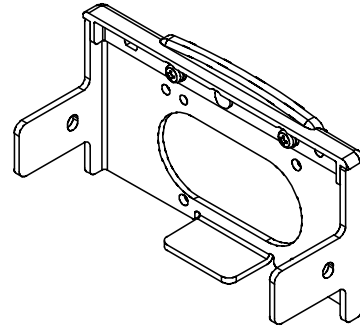

EX600-ZMV2 (Specified for SY series)

Enclosed parts: Round head screw (M4 x 6), 2 pcs.  
Round head screw (M3 x 8), 4 pcs.

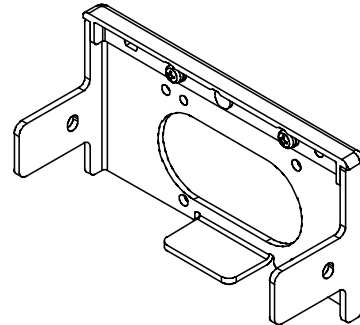

### (2) End plate bracket

EX600-ZMA2

Enclosed parts: Round head screw (M4 x 20), 1 pc.  
P tight screw (4 x 14), 2 pcs.

EX600-ZMA3 (Specified for SY series)

Enclosed parts: Round head screw (M4x20) with washer, 1 pc.  
P tight screw (4 x 14), 2 pcs.

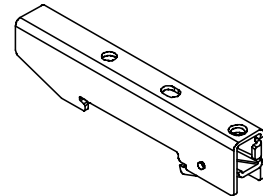

### (3) Intermediate support bracket

EX600-ZMB1: For direct mounting

Enclosed parts: Round head screw (M4 x 5), 2 pcs.

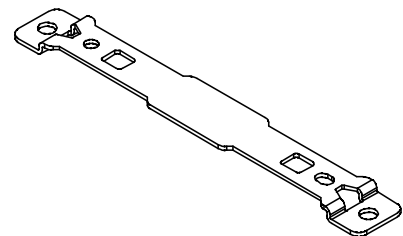

EX600-ZMB2: For DIN rail mounting

Enclosed parts: Round head screw (M4 x 6), 2 pcs.

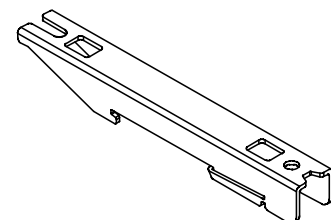

(4)Seal cap (10 pcs.)

EX9-AWES: For M8

EX9-AWTS: For M12

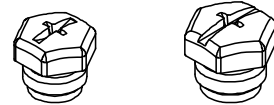

(5)Marker (1 sheet, 88 pcs.)

EX600-ZT1

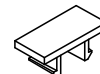

(6)Assembled type connector

PCA-1446553: For EtherNet/IP™ communication, M12 (4 pin) Plug, D code

PCA-1578078: For power supply, 7/8 inch, Plug, Cable O.D. 12 to 14 mm

PCA-1578081: For power supply, 7/8 inch, Socket, Cable O.D. 12 to 14 mm

(7)Power supply cable

PCA-1558810: Cable with 7/8 inch connector, Socket, Straight 2 m

PCA-1558823: Cable with 7/8 inch connector, Socket, Straight 6 m

PCA-1558836: Cable with 7/8 inch connector, Socket, Right angle 2 m

PCA-1558849: Cable with 7/8 inch connector, Socket, Right angle 6 m

PCA-1564927: Cable with M12 connector, B code, Socket, Straight 2 m, SPEEDCON compatible

PCA-1564930: Cable with M12 connector, B code, Socket, Straight 6 m, SPEEDCON compatible

PCA-1564943: Cable with M12 connector, B code, Socket, Right angle 2 m, SPEEDCON compatible

PCA-1564969: Cable with M12 connector, B code, Socket, Right angle 6 m, SPEEDCON compatible

(8)EtherNet/IP™ communication cable

PCA-1446566: Cable with M12 connector, D code, Plug, Straight 5 m, SPEEDCON compatible

EX9-AC010EN-PSRJ: Cable with M12 connector, D code-RJ45, Plug, Straight 1 m

EX9-AC020EN-PSRJ: Cable with M12 connector, D code-RJ45, Plug, Straight 2 m

EX9-AC030EN-PSRJ: Cable with M12 connector, D code-RJ45, Plug, Straight 3 m

EX9-AC050EN-PSRJ: Cable with M12 connector, D code-RJ45, Plug, Straight 5 m

EX9-AC100EN-PSRJ: Cable with M12 connector, D code-RJ45, Plug, Straight 10 m

(9)IO-Link communication cable

EX9-AC005-SSPS: Cable with M12 connector, Socket, Plug, Straight 0.5 m

EX9-AC010-SSPS: Cable with M12 connector, Socket, Plug, Straight 1.0 m

EX9-AC020-SSPS: Cable with M12 connector, Socket, Plug, Straight 2.0 m

EX9-AC030-SSPS: Cable with M12 connector, Socket, Plug, Straight 3.0 m

EX9-AC050-SSPS: Cable with M12 connector, Socket, Plug, Straight 5.0 m

EX9-AC100-SSPS: Cable with M12 connector, Socket, Plug, Straight 10.0 m

Revision history
A: Contents revised in several places [May 2024]

# SMC Corporation

Tel: + 81 3 5207 8249 Fax: +81 3 5298 5362  
URL <https://www.smcworld.com>

---

Note: Specifications are subject to change without prior notice and any obligation on the part of the manufacturer.  
© SMC Corporation All Rights Reserved

