



# Operation Manual

**PRODUCT NAME**

**Pilot Check Valve Compact Type**

**MODEL/ Series/ Product Number**

**AKP-\* \* \* \* - \***

**SMC Corporation**

# Contents

1. Safety Instructions	2~ 3
2. Specific Product Precautions	4~10
3. Application	11
4. Specifications	11
5. Malfunctions and Countermeasures	11
6. Construction	12~14



# Pilot Check Valve Compact Type AKP Series Safety Instructions

These safety instructions are intended to prevent hazardous situations and/or equipment damage. These instructions indicate the level of potential hazard with the labels of “**Caution**,” “**Warning**” or “**Danger**.” They are all important notes for safety and must be followed in addition to International Standards (ISO/IEC)<sup>\*)</sup>, and other safety regulations.

\*1) ISO 4414: Pneumatic fluid power - General rules and safety requirements for systems and their components  
ISO 4413: Hydraulic fluid power - General rules and safety requirements for systems and their components  
IEC 60204-1: Safety of machinery - Electrical equipment of machines - Part 1: General requirements  
ISO 10218-1: Robots and robotic devices - Safety requirements for industrial robots - Part 1: Robots  
etc.



## **Danger**

**Danger** indicates a hazard with a high level of risk which, if not avoided, will result in death or serious injury.



## **Warning**

**Warning** indicates a hazard with a medium level of risk which, if not avoided, could result in death or serious injury.



## **Caution**

**Caution** indicates a hazard with a low level of risk which, if not avoided, could result in minor or moderate injury.



## **Warning**

### **1. The compatibility of the product is the responsibility of the person who designs the equipment or decides its specifications.**

Since the product specified here is used under various operating conditions, its compatibility with specific equipment must be decided by the person who designs the equipment or decides its specifications based on necessary analysis and test results. The expected performance and safety assurance of the equipment will be the responsibility of the person who has determined its compatibility with the product. This person should also continuously review all specifications of the product referring to its latest catalog information, with a view to giving due consideration to any possibility of equipment failure when configuring the equipment.

### **2. Only personnel with appropriate training should operate machinery and equipment.**

The product specified here may become unsafe if handled incorrectly. The assembly, operation and maintenance of machines or equipment including our products must be performed by an operator who is appropriately trained and experienced.

### **3. Do not service or attempt to remove product and machinery/equipment until safety is confirmed.**

1. The inspection and maintenance of machinery/equipment should only be performed after measures to prevent falling or runaway of the driven objects have been confirmed.
2. When the product is to be removed, confirm that the safety measures as mentioned above are implemented and the power from any appropriate source is cut, and read and understand the specific product precautions of all relevant products carefully.
3. Before machinery/equipment is restarted, take measures to prevent unexpected operation and malfunction.

### **4. Our products cannot be used beyond their specifications. Our products are not developed, designed, and manufactured to be used under the following conditions or environments. Use under such conditions or environments is not covered.**

1. Conditions and environments outside of the given specifications, or use outdoors or in a place exposed to direct sunlight.
2. Use for nuclear power, railways, aviation, space equipment, ships, vehicles, military application, equipment affecting human life, body, and property, fuel equipment, entertainment equipment, emergency shut-off circuits, press clutches, brake circuits, safety equipment, etc., and use for applications that do not conform to standard specifications such as catalogs and operation manuals.
3. Use for interlock circuits, except for use with double interlock such as installing a mechanical protection function in case of failure. Please periodically inspect the product to confirm that the product is operating properly.



# Pilot Check Valve Compact Type AKP Series Safety Instructions

## **Caution**

**We develop, design, and manufacture our products to be used for automatic control equipment, and provide them for peaceful use in manufacturing industries.**

**Use in non-manufacturing industries is not covered.**

Products we manufacture and sell cannot be used for the purpose of transactions or certification specified in the Measurement Act.

The new Measurement Act prohibits use of any unit other than SI units in Japan.

## **Limited warranty and Disclaimer/Compliance Requirements**

The product used is subject to the following “Limited warranty and Disclaimer” and “Compliance Requirements”.

Read and accept them before using the product.

### **Limited warranty and Disclaimer**

1. The warranty period of the product is 1 year in service or 1.5 years after the product is delivered, whichever is first.\*2)

Also, the product may have specified durability, running distance or replacement parts. Please consult your nearest sales branch.

2. For any failure or damage reported within the warranty period which is clearly our responsibility, a replacement product or necessary parts will be provided.

This limited warranty applies only to our product independently, and not to any other damage incurred due to the failure of the product.

3. Prior to using SMC products, please read and understand the warranty terms and disclaimers noted in the specified catalog for the particular products.

**\*2) Vacuum pads are excluded from this 1 year warranty.**

A vacuum pad is a consumable part, so it is warranted for a year after it is delivered.

Also, even within the warranty period, the wear of a product due to the use of the vacuum pad or failure due to the deterioration of rubber material are not covered by the limited warranty

### **Compliance Requirements**

1. The use of SMC products with production equipment for the manufacture of weapons of mass destruction (WMD) or any other weapon is strictly prohibited.

2. The exports of SMC products or technology from one country to another are governed by the relevant security laws and regulations of the countries involved in the transaction. Prior to the shipment of a SMC product to another country, assure that all local rules governing that export are known and followed.

## 2. Specific Product Precautions

### Design/ Selection

#### Warning

##### (1) Confirm the specifications.

The products are designed to be used in compressed air systems (including vacuum) only.

Do not operate at pressures, temperatures, etc., beyond the range of specifications, as this can cause damage or malfunction. (Refer to the specifications.)

We do not guarantee against any damage if the product is used outside of the specifications range.

##### (2) Do not disassemble the product or make any modifications, including additional machining.

Doing so may cause human injury and/or an accident.

##### (3) Sonic conductance (C) and critical pressure ratio (b) values for products are representative values.

##### (4) Check if PTFE can be used in application.

PTFE powder (Polytetrafluoroethylene resin) is included in the seal material of the male thread type piping taper thread. Confirm that the use of it will not cause any adverse effect on the system. Please contact SMC if the Safety Data Sheet (SDS) is required.

##### (5) The pilot check valve is a product aimed at the control of the actuator via a temporary intermediate stop.

The pilot check valve is used for temporarily stopping the actuator. Until a pilot signal is input, the valve shuts off the flow path from 2 to 1 and the actuator stops. When a pilot signal is input, the flow path from 2 to 1 is opened. When the residual pressure exhaust button is operated, all flow paths (2 to 1, 21, and exhaust port) are opened.

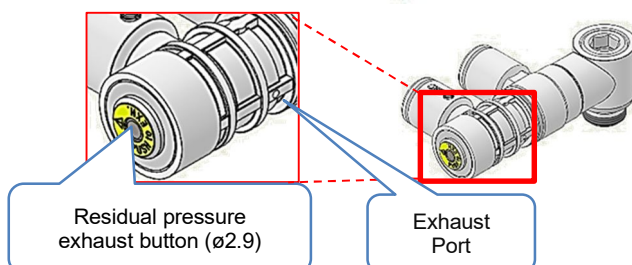
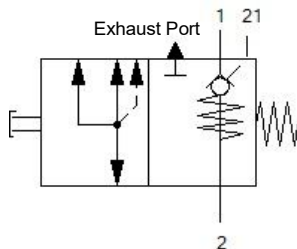

### Design/ Selection

#### Warning

##### (6) The product cannot be used for accurate and precise intermediate stop of the actuator.

Due to the compressibility of air as a fluid, the actuator will continue to move until it reaches a position of pressure balance, even though the pilot check valve closes with an intermediate stop signal.

##### (7) The product cannot be used for retention of the stop position for long hours.

Pilot check valve and actuators are not guaranteed for zero air leakage. Therefore, it is sometimes not possible to hold a stop position for extended period of time. In the event that holding for an extended time is necessary, a mechanical means for holding should be devised.

##### (8) When “AKP-\*-M5” or “AKP-\*-U10” is used, pay attention to the residual pressure on the port 1 side.

Due to the residual pressure on the port 1 side, the responsiveness of the intermediate stop of the actuator may become slower. Use “AKP-\*-M5” or “AKP-\*-U10” in a circuit in which an exhaust center valve is used so that no residual pressure is generated on the port 1 side.

##### (9) Pay attention to the residual pressure within the actuator at the time of intermediate stop.

When the actuator is stopped at the intermediate position by this product, there may be pressure contained inside the actuator, therefore the actuator may suddenly move when the residual pressure is released. Before operating the residual pressure exhaust button, confirm that the surrounding area is secure from any potential hazards or accidents occurring.

##### (10) Use this product after checking the surrounding areas in advance before the release of residual pressure.

The actuator may move at a speed quicker than the intended speed from the original circuit set up when exhausting from the residual pressure release. Confirm this speed will not create additional hazards and pay attention to the air discharged from the exhaust port.

## Design/ Selection

### ⚠ Warning

#### (11) Pay attention to the motion of the actuator at the time of release of the residual pressure.

When operating the residual pressure exhaust button or conducting maintenance or inspection, the actuator may start moving due to the residual pressure. Take appropriate measures in advance to prevent an actuator movement from posing a hazard.

Also pay attention to the operation speed and the movement of the cylinder during exhaust. When an exhaust center valve is used on the actuator supply side (Figure A below), the residual pressure is released from port 1, 21, and the exhaust port. However, when using a closed center valve like the example shown in Figure B below, air is discharged only from port 21 and the exhaust port. Use "AKP-\*-M5" or "AKP-\*-U10" in a circuit with an exhaust center valve.

For the moving direction of the actuator against the corresponding exhaust side, refer to the figure below.

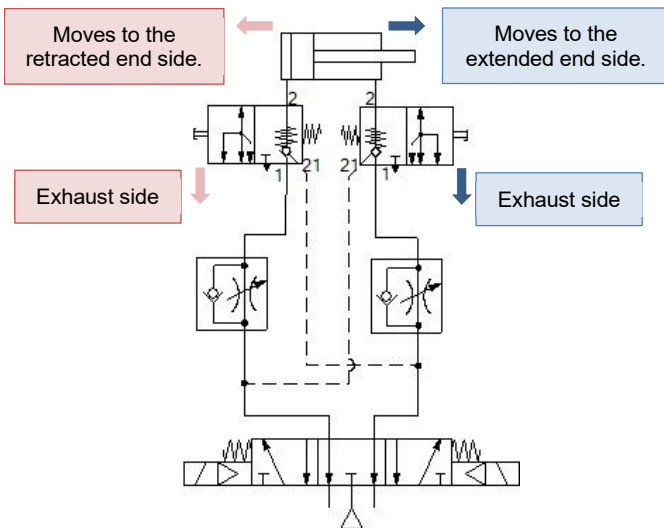

Figure A: Example of piping using exhaust center valve

\*Use "AKP-\*-M5" or "AKP-\*-U10" in a circuit with an exhaust center valve.

## Design/ Selection

### ⚠ Warning

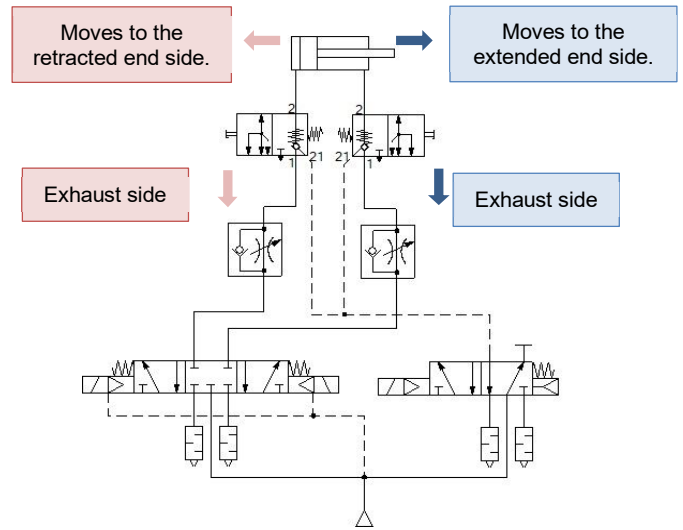

Figure B: Example of piping using closed center valve (Recommended example)

\* "AKP-\*-M5" and "AKP-\*-U10" cannot be used in a circuit in which only a closed center valve is used. When you wish to use "AKP-\*-M5" or "AKP-\*-U10" together in a circuit with a closed center valve, please contact SMC.

#### (12) Push the residual pressure exhaust button all the way to the end position by using a tool.

Push the residual pressure exhaust button all the way to the end position by using a tool having a tip diameter of  $\phi 2.8$  or below. See the table below for the depth and force to push the tool. The higher the residual pressure, the more force is needed to press the override button completely.

Part number	Operating force [N] (reference value)	Operating depth [mm]
AKP-*-M5/U10	5.3 to 8.2	3.5
AKP-*-01	5.1 to 11.9	3.9
AKP-*-02	6.7 to 19.5	3.8
AKP-*-03	10.6 to 34.4	4.7
AKP-*-04	17.1 to 54.4	5.8

#### (13) After operating the residual pressure exhaust button, confirm that the button has returned to the normal position.

Make sure that the residual pressure exhaust button has returned to the end face of the product before operating again. If the button cannot return to the normal position, the intermediate stop function of the actuator will not work. Therefore, replace the product with a new one.

## Design/ Selection

### Warning

(14) **Pay attention to the motion of the actuator at the time of restart after the release of residual pressure.**

When restarting the product after releasing the residual pressure, check the initial driving direction, confirm that the work area is secured, and then restart the product. Failure to follow this instruction may cause the actuator to suddenly move.

(15) **When the product is used in a balance control circuit, the check valve may not be released even when the pilot pressure is 50% of the operating pressure. In this case, obtain the pilot pressure from a position so that the pilot pressure is equivalent to the operating pressure.**

When using the product at the minimum operating pressure, set the pilot pressure to 0.1 MPa or higher. For AKP-\*-M5/U10 pilot check valve, pilot pressure to 0.15 MPa or higher.

(16) **As a reference, we have confirmed through our durability tests that the check valve has a durability against 10 million cycles of ON and OFF operations and the residual pressure exhaust button has a durability against 10,000 cycles of operation at the maximum operating pressure.**

However, note that the tests were conducted under limited conditions.

(17) **In the following cases, malfunctioning or noise due to oscillation may occur.**

- When the differential pressure between the port 1 side and port 2 side is smaller than the minimum operating pressure
- When the IN side piping of the product or the effective area of the directional control valve is smaller than that of the product
- When the pressure drop on the port 1 side is slower than that of the port 2 side during operation of the product
- When the supply pressure at the port 21 is reduced (Refer to the piping diagram below.)
- When the port 1 side piping (tube) is bent or crushed

## Design/ Selection

### Warning

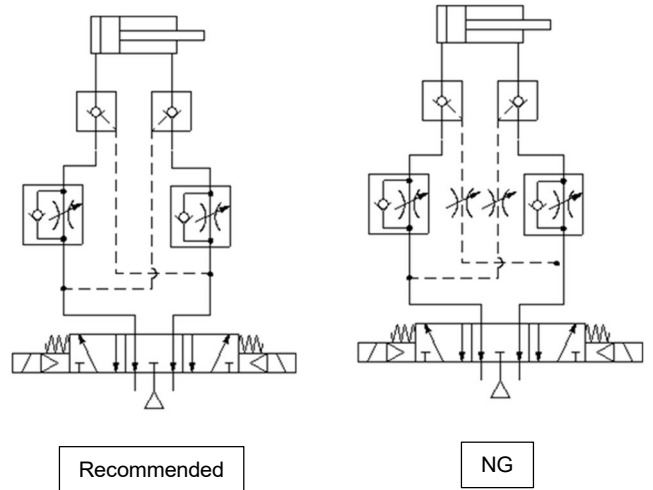

## Mounting

### Warning

#### (1) Operation Manual

Install the products and operate it only after reading the operation Manual carefully and understanding its contents. Also, keep the Manual where it can be referred to as necessary.

#### (2) Ensure sufficient space for maintenance activities.

When installing the products, allow access for maintenance.

#### (3) Tighten threads with the proper tightening torque.

When installing the products, follow the listed proper torque.

#### (4) Use R external threads with Rc internal threads and NPT external threads with NPT internal threads and G external threads with G internal threads.

#### (5) Check piping directions before mounting.

Connect the inlet to the directional control valve and the outlet to the actuator.

#### (6) Do not apply excessive force or shock to the body or fittings with an impact tool.

It can cause damage or air leakage.

#### (7) For handling One-touch fittings, refer to the Fittings and Tubing Precautions.

## Mounting

### **Warning**

**(8) Pay attention to the method of mounting on the cylinder.**

For the horizontal type, a hexagon wrench needs to be used. The product cannot be mounted with an open-end wrench. For the mounting of the vertical type, an open-end wrench needs to be used. Note that the mounting method differs between the vertical type and the horizontal type.

**(9) Conduct mounting and removal of the vertical type by holding the width across flats of the body B and turning it by using an appropriate wrench.**

Do not apply torque at other points as the product may be damaged. Rotate Body A manually for positioning after installation.

**(10) To install and remove the product with hexagonal hole, use an appropriate hex key and push it into the hexagon hole of the stud.**

Do not apply torque at other points as the product may be damaged. Rotate Body A or B manually for positioning after installation. Refer to the applicable dimension of the hexagon wrench.

Connection Thread	Hex Key (Nominal)	
	Metric [mm]	Imperial [Inch]
M5, 10-32UNF	2.5	-
R1/8, G1/8	6	-
NPT1/8	-	7/32"
R1/4, G1/4	8	-
NPT1/4	-	5/16"
R3/8, G3/8	10	-
NPT3/8	-	3/8"
R1/2, G1/2	10	-
NPT1/2	-	3/8"

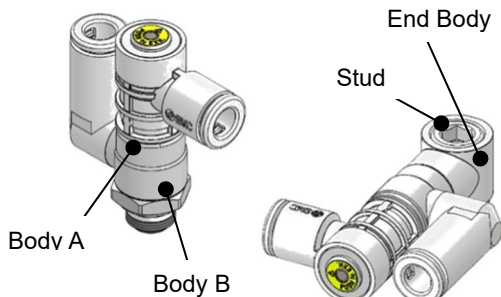

\*Illustrations of vertical type (left) and horizontal type (right) products

**(11) Do not use the product in application that involves continuous rotation. Do not use the product in a manner that applies a moment load.**

Failure to follow these instructions may cause the fitting or product to be damaged.

## Mounting

### **Caution**

**(1) For M5, 10-32UNF**

**① Tightening method**

First, tighten it by hand, then give it an additional 1/6 turn to 1/4 turn with a wrench. A reference value for the tightening torque is 1 to 1.5 N·m.

Note) Excessive tightening may damage the thread portion or deform the gasket and cause air leakage.

If the screw is too shallowly screwed in, it may come loose or air may leak.

**② Chamfered area for female thread**

Conforming to ISO 16030 (air pressure fluid dynamics – connection – ports and stud ends), the chamfered dimensions shown in the table below are recommended.

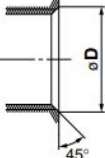

Female thread size	Chamfered port size $\phi D$ (Recommended value)
M5	5.1 to 5.4
10-32UNF	5.0 to 5.3

**(2) For R, NPT, G thread**

**① Tightening method**

To tighten a screw on the vertical type, first tighten it by hand and then hold the width across flats of the body B and turn it by using an appropriate wrench. To tighten a screw on the horizontal type, tighten it by hand and then insert an appropriate hexagon wrench to the hexagonal socket of the stud and turn it.

Refer to the reference values in the table below for the tightening torque.

Connection thread size	Tightening Torque (N·m)
1/8	3 to 5
1/4	8 to 12
3/8	15 to 20
1/2	20 to 25

**② Chamfered area for female thread**

By chamfering as shown in the following table, machining of threads is easier and effective for burr prevention.

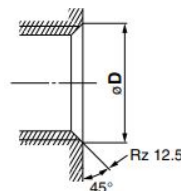

Connection Thread size	Chamfered port size $\phi D$ (Recommended value)		
	Rc	NPT	G Face seal
1/8	10.2 to 10.4	10.5 to 10.7	9.8 to 10.2
1/4	13.6 to 13.8	14.1 to 14.3	13.3 to 13.7
3/8	17.1~17.3	17.4~17.6	16.8~17.2
1/2	21.4~21.6	21.7~21.9	21.0~21.4

\*G thread (face seal) complies with ISO16030-2001.



## Piping Threads with Sealant

### **Caution**

- (1) If the fitting is tightened with excessive torque, a large amount of sealant will seep out. Remove the excess sealant.
- (2) Insufficient tightening may loosen the threads, or cause air leakage.
- (3) **Reuse**
  - ① Normally, fittings with a sealant can be reused 2 to 3 times.
  - ② To prevent air leakage through the sealant, remove any loose sealant stuck to the fitting by blowing air over the threaded portion.
  - ③ If the sealant no longer provides effective sealing, wrap sealing tape over the sealant before reusing. Do not use the sealant in any form other than a tape type.
- (4) Once the fitting has been tightened, backing it out to its original position often causes the sealant to become defective. Air leakage will occur
- (5) Use R external threads with Rc internal threads and NPT external threads with NPT internal threads.

## Piping

### **Caution**

- (1) Refer to the Fittings & Tubing Precautions for handling One-touch fittings.
- (2) **Preparation before piping**

Before piping is connected, it should be thoroughly blown out with air (flushing) or washed to remove chips, cutting oil and other debris from inside the pipe.
- (3) **Winding of sealant tape**

When screwing together pipes and fittings, etc., be certain that chips from the pipe threads and sealing material do not get inside the pipe. Also, when the sealant tape is used, leave approx. 1 thread ridges exposed at the end of the threads.

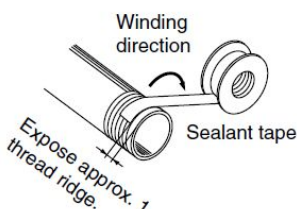

## Precautions for One-Touch Tube Fittings

### Piping

### **Caution**

- (1) **Connection and disconnection of tube from one-touch fitting**
  - ① **Installation of tube**
    - 1) Cut the tube perpendicularly, being careful not to damage the external surface. Use an SMC tube cutter TK-1, 2, 3 or 6. Do not cut the tubing with pliers, nippers, scissors, etc., otherwise the tubing will be deformed and problems may result.
    - 2) The outside diameter of the polyurethane tubing swells when internal pressure is applied to it. Therefore, it may be impossible to re-insert the tubing into One-touch fittings. Check the tubing outside diameter, and when the accuracy of the outside diameter is +0.07mm or larger for  $\phi 2$ , and +0.15mm or larger for other sizes, re-insert it into the One-touch fitting without cutting the tube. When the tubing is re-inserted into the One-touch fitting, confirm that the tubing goes through the release button smoothly.
    - 3) Grasp the tubing, and slowly push it straight (0 to 5°) into the One-touch fitting until it comes to a stop.
    - 4) Pull the tubing back gently to make sure it has a positive seal. Insufficient installation may cause air to leak or the tubing to release. As a guide for checking if the tubing is pulled out or not, refer to the following table.
  - ② **Removal of the tube**
    - 1) Push the release button flange evenly and sufficiently to release the tube. Do not push in the tubing before pressing the release button.
    - 2) Pull out the tubing while keeping the release button depressed. If the release button is not held down sufficiently, the tubing cannot be withdrawn.
    - 3) To reuse the tubing, remove the previously lodged portion of the tubing. If the lodged portion is left on without being removed, it may result in air leakage and make the removal of the tubing difficult.

## Piping

### **Caution**

**(2) Connection of the metal rod accessories**

Do not use tube, resin plug, reducer, etc. after connecting a fitting with a metal rod (KC series, etc.) to a One-touch fitting. This can cause the disconnection of tube.

**(3) When mounting the tube, resin plug or metal rod, do not press the release button.**

Do not press the release button unnecessarily before mounting tubing, resin plugs and metal rods. This can cause the disconnection of tube.

**(4) When using a tubing other than from SMC, confirm that the tube material and the O.D. accuracy satisfy the following specifications.**

- 1) Nylon tube  $\pm 0.1$  mm max.
- 2) Soft nylon tube  $\pm 0.1$  mm max.
- 3) Polyurethane tube  $+0.15$  mm at max.  
Within  $-0.2$  mm

Do not use the tubing which does not satisfy the specified tubing O.D. accuracy, or if the tubing has a different I.D., material, hardness, or surface roughness from those of SMC's tubing. If you have any questions, please consult SMC. Failure to satisfy the specifications may lead to difficulty in connecting the tubing, leakage, disconnection of the tubing, or fitting damage.

### Recommended Piping Conditions

**(1) When connecting piping to the One-touch fitting, use a pipe length with sufficient margin, in accordance with the piping conditions shown in Figure 1.**

Also, when using a tying band, etc., to bind the piping together, make sure that external force does not come to bear on the fitting. (see Figure 2)

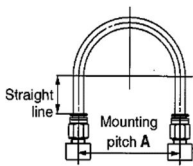

Figure 1 Recommended piping

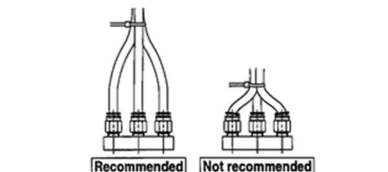

Fig. 2 When using a tying band to bind the piping together

Unit:mm

Tubing size	Mounting pitch A			Straight-line length
	Nylon tube	Soft nylon tube	Polyurethane tube	
$\phi 4, \phi 5/32''$	56 or more	44 or more	26 or more	20 or more
$\phi 6$	84 or more	66 or more	39 or more	30 or more
$\phi 1/4''$	89 or more	70 or more	57 or more	32 or more
$\phi 8, \phi 5/16''$	112 or more	88 or more	52 or more	40 or more
$\phi 10$	140 or more	110 or more	69 or more	50 or more
$\phi 12$	168 or more	132 or more	88 or more	60 or more

## Air Supply

### **Warning**

**(1) Type of fluids**

Use compressed air as the fluid used.

**(2) When there is a large amount of drainage**

Compressed air containing a large amount of drainage can cause the malfunction of pneumatic equipment. An air dryer or water separator should be installed upstream from filters.

**(3) Drain flushing**

If condensation in the drain bowl is not emptied on a regular basis, the bowl will overflow and allow the condensation to enter the compressed air lines. This causes the malfunction of pneumatic equipment.

If the drain bowl is difficult to check and remove, the installation of a drain bowl with an auto drain option is recommended.

For compressed air quality, refer to SMC catalog "Compressed Air Purification System".

**(4) Use clean air**

Do not use compressed air that contains chemicals, synthetic oils that include organic solvents, salt, corrosive gases, etc., as it can cause damage or malfunction.

### **Caution**

**(1) Install an air filter.**

Install an air filter upstream near the valve.

For the filtration rating, select 5  $\mu\text{m}$  or below, or select a rating equivalent to or lower than ISO 8573-1:2010 [6:4:4]\*.

\*This is equivalent to the filtration performance achieved when an air filter is attached for inlet side compressed air with purity class of [7:4:4].

**(2) Ensure that the fluid and ambient temperatures are within the specified range.**

If the fluid temperature is 5  $^{\circ}\text{C}$  or less, the moisture in the circuit could freeze, causing damage to the seals or leading to equipment malfunction. Therefore, take appropriate measures to prevent freezing.

For compressed air quality, refer to SMC catalog "Compressed Air Purification System".

## Operating environment

### **Warning**

- (1) **Do not use in an atmosphere containing corrosive gases, chemicals, sea water, water, water steam, or where there is direct contact with any of these.**
- (2) **Do not expose the product to direct sunlight for an extended period of time.**
- (3) **Do not mount the product in locations where it is exposed to radiant heat.**

## Maintenance

### **Warning**

- (1) **Perform maintenance and inspection according to the procedures indicated in the operation manual.**  
If handled improperly, malfunction or damage of machinery and equipment may occur.
- (2) **Maintenance work**  
If handled improperly, compressed air can be dangerous.  
Assembly, handling, repair and element replacement of pneumatic systems should be performed by a knowledgeable and experienced person.
- (3) **Drain flushing**  
Remove drainage from air filters regularly.
- (4) **Removal of equipment, and supply/exhaust of compressed air**  
Before components are removed, first confirm that measures are in place to prevent workpieces from dropping, run-away equipment, etc.  
Then, Cut the supply pressure and electric power, and exhaust all compressed air from the system using the residual pressure release function.  
When machinery is restarted, proceed with caution after confirming that appropriate measures are in place to prevent sudden movement.

### 3. Application

This product is designed to provide a temporary intermediate stop of a pneumatic actuator.

### 4. Specifications

Fluid	Air
Proof pressure	1.05MPa
Maximum operating pressure	0.7MPa
Minimum operating pressure	0.1MPa
Pilot check valve operating pressure	More than 50% of operating pressure (0.1 MPa or more <sup>(note 2)</sup> )
Ambient and fluid temperature	-5 to 60°C (No freezing)
Applicable tube materials <sup>(note 1)</sup>	Nylon, soft nylon, polyurethane, FEP, PFA

Note1: Pay attention to the maximum operating pressure for soft nylon and polyurethane.

Note2: For AKP-\*-M5/U10 pilot check valve, pressure must be more than 50% of operating pressure and 0.15 MPa or more.

### 5. Malfunctions and Countermeasures

Trouble	Possible causes	Countermeasure
Actuator is Unable to reach an intermediate stop position.	The piping orientation is incorrect.	Connect the IN (port 1, port 21) side to the directional control valve, and OUT (port 2) side to the actuator.
	Dust inside.	Conduct air blow from the port 1 (IN) side. A foreign matter may be attached to the valve. If the condition does not improve even after air blow, install an air filter to the piping, and replace the product with a new one.
	The residual pressure exhaust button has not returned to the normal position.	If the button has not returned to the end face of the product, the product may have failed. Replace the product with new one.
Air leaks from the One-touch fitting. Or the tubing disconnects.	Tubing has been cut using pliers or nipper.	Use tube cutters.
	The tolerance of the outside diameter of the tubing in use is beyond the specification.	When using a tubing other than from SMC, confirm that the tube material and the O.D. accuracy satisfy the following specifications. 1) Nylon tube           ±0.1 mm max. 2) Soft nylon tube     ±0.1 mm max. 3) Polyurethane tube +0.15 mm at max. Within -0.2 mm

# 6. Construction

**Vertical Elbow type**

Seal method: Face seal  
For G

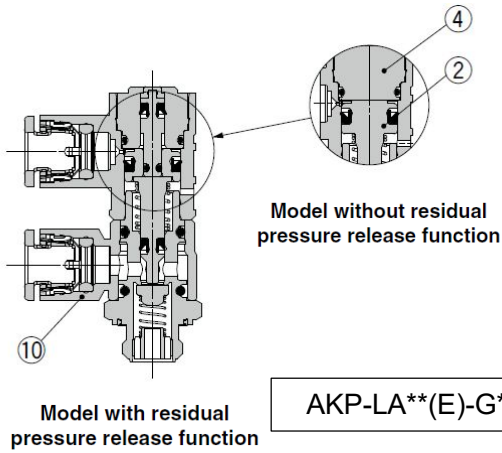

**Vertical Universal type**

Seal method: Face seal  
For G

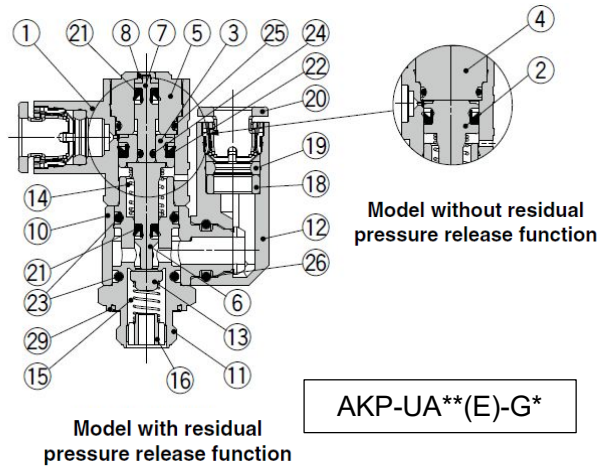

**Horizontal Elbow type**

Seal method: Face seal  
For G

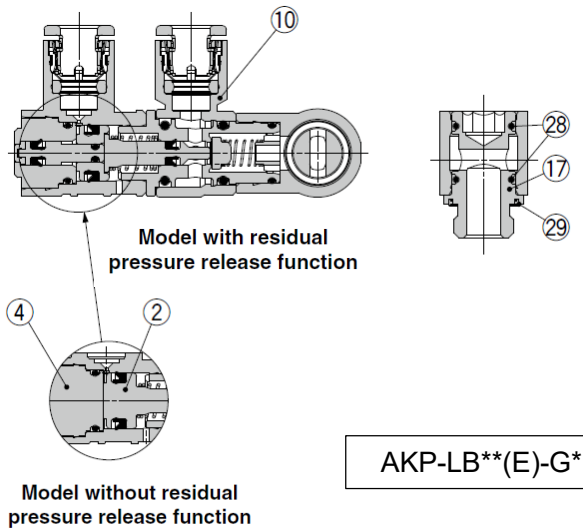

**Horizontal Universal type**

Seal method: Face seal  
For G

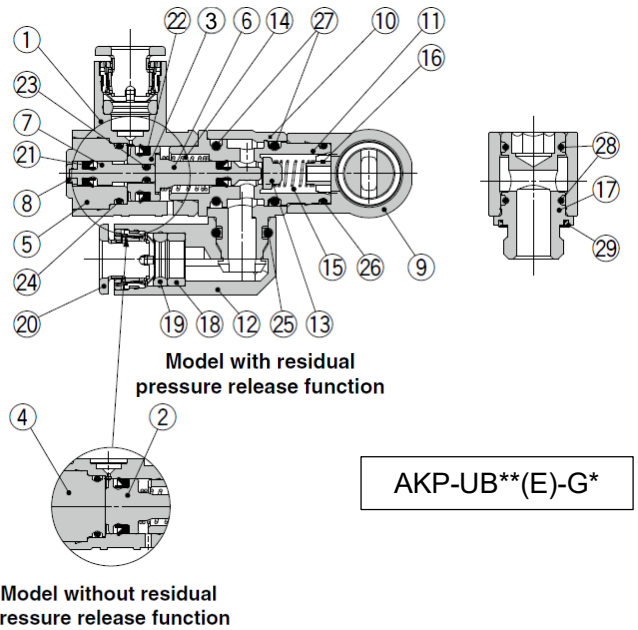

### Horizontal Elbow type

Seal method: Sealant  
For R, NPT

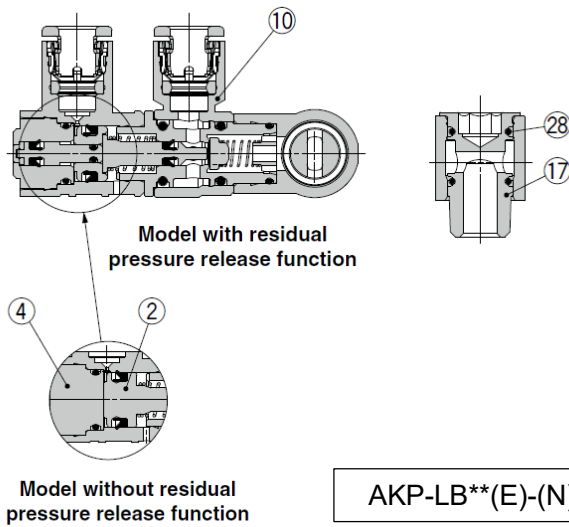

AKP-LB\*\*(E)-(N)\*

### Horizontal Universal type

Seal method: Sealant  
For R, NPT

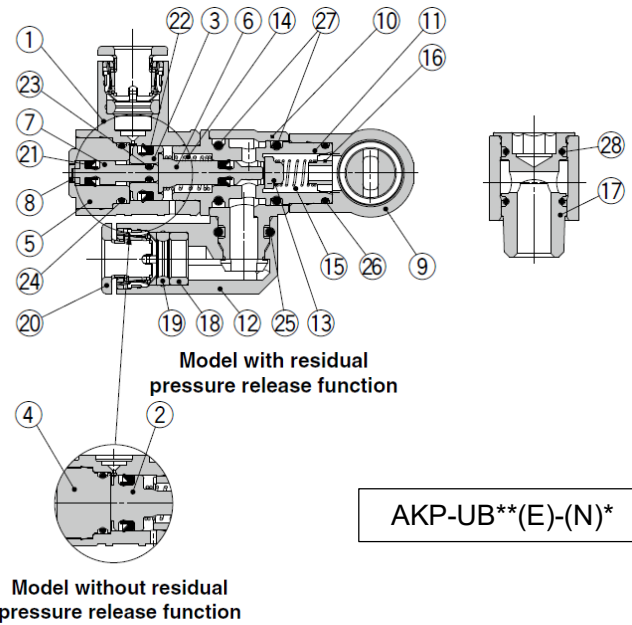

AKP-UB\*\*(E)-(N)\*

#### Component Parts

No.	Description	Material	Note
1	Pilot body	PBT	
2	Piston A	Brass	Electroless nickel plating
3	Piston B	Brass	Electroless nickel plating
4	End cover A	Brass	Electroless nickel plating
5	End cover B	Brass	Electroless nickel plating
6	Piston rod	Brass	Electroless nickel plating
7	Push rod	Aluminum alloy	
8	Push rod cover	PBT	
9	End Body	PBT	
10	Body A	PBT	
11	Body B	Brass	Electroless nickel plating
12	Elbow body	PBT	
13	Valve	NBR	
14	Spring	Stainless steel	
15	Spring	Stainless steel	

No.	Description	Material	Note
16	Guide	Brass	Electroless nickel plating
17	Stud	Brass	Electroless nickel plating
18	Spacer	POM or PBT	
19	Seal	NBR	
20	Cassette	—	
21	Seal	NBR	
22	Seal	NBR	
23	O-ring	NBR	
24	O-ring	NBR	
25	O-ring	NBR	
26	O-ring	NBR	
27	O-ring	NBR	
28	O-ring	NBR	
29	Seal	NBR	G thread type

**Vertical Elbow type**

Seal method: **Gasket seal**  
For **M5, 10-32UNF**

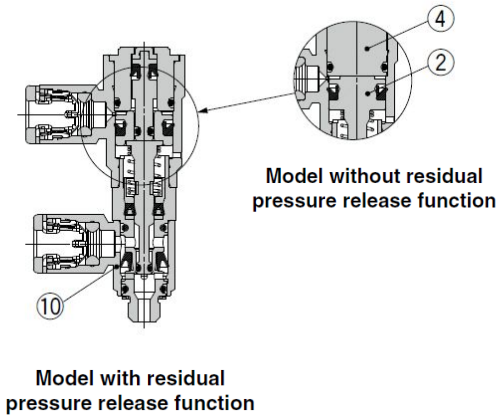

AKP-LA\*\*(E)-M5/U10

**Vertical Universal type**

Seal method: **Gasket seal**  
For **M5, 10-32UNF**

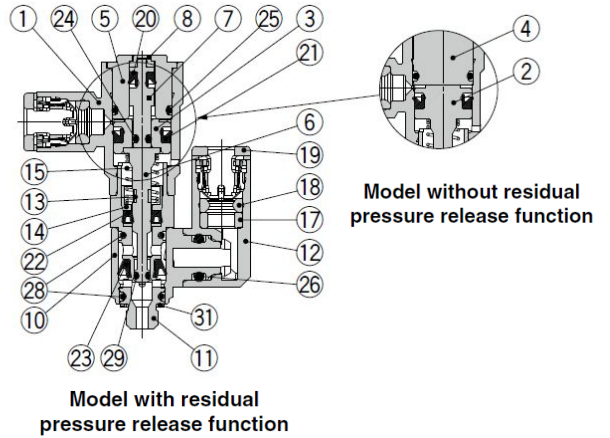

AKP-UA\*\*(E)-M5/U10

**Horizontal Elbow type**

Seal method: **Gasket seal**  
For **M5, 10-32UNF**

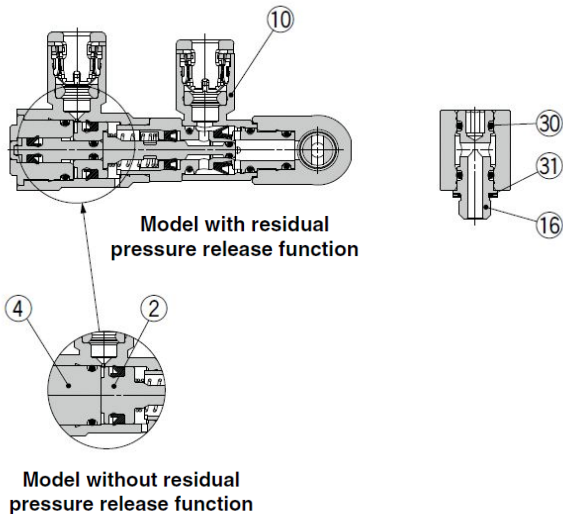

AKP-LB\*\*(E)-M5/U10

**Horizontal Universal type**

Seal method: **Gasket seal**  
For **M5, 10-32UNF**

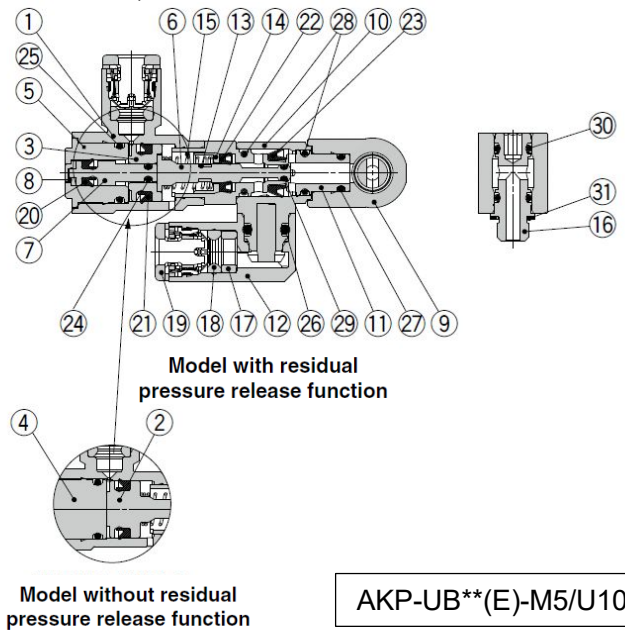

AKP-UB\*\*(E)-M5/U10

Component Parts

No.	Description	Material	Note
1	Pilot body	PBT	
2	Piston A	Brass	Electroless nickel plating
3	Piston B	Brass	Electroless nickel plating
4	End cover A	Brass	Electroless nickel plating
5	End cover B	Brass	Electroless nickel plating
6	Piston rod	Brass	Electroless nickel plating
7	Push rod	Aluminum alloy	
8	Push rod cover	PBT	
9	End Body	PBT	
10	Body A	PBT	
11	Body B	Brass	Electroless nickel plating
12	Elbow body	PBT	
13	Ring	POM	
14	Seal retainer	Brass	Electroless nickel plating
15	Spring	Stainless steel	

No.	Description	Material	Note
16	Stud	Brass	Electroless nickel plating
17	Spacer	POM or PBT	
18	Seal	NBR	
19	Cassette	—	
20	Seal	NBR	
21	Seal	NBR	
22	Seal	NBR	
23	U-seal	HNBR	
24	O-ring	NBR	
25	O-ring	NBR	
26	O-ring	NBR	
27	O-ring	NBR	
28	O-ring	NBR	
29	O-ring	NBR	
30	O-ring	NBR	
31	Gasket	Stainless steel/NBR	

#### Revision history

Version 1: Added model size M5, U10, 3/8, 1/2

Version 2: Change format

Mounting Warning (10) Correction

Version 3: Delete SMC address.

"Safety Instruction" changed.

## SMC Corporation

Tel: + 81 3 5207 8249 Fax: +81 3 5298 5362

URL <https://www.smeworld.com>

---

Note: Specifications are subject to change without prior notice and any obligation on the part of the manufacturer.  
© SMC Corporation All Rights Reserved