



Operation Manual

PRODUCT NAME

Filter Regulator

MODEL / Series / Product Number

AW30- (F, N) 02 ~ (F, N) 04 (C) -2 (R) -X2622 (A, B, C)

AW40- (F, N) 02 ~ (F, N) 06 (C) -2 (R) -X2622 (A, B, C)

SMC Corporation

Contents

	Page
1. SAFETY INSTRUCTIONS	2-5
2. APPLICATION	6
3. SPECIFICATIONS	6
4. HOW TO ORDER	7
5. TROUBLESHOOTING	8
6. CONSTRUCTION / PARTS LIST	9
7. REPLACEMENT PROCEDURE	10-11
8. DISASSEMBLY DRAWING	12-13
9. DIMENSIONS	14



Safety Instructions

These safety instructions are intended to prevent hazardous situations and/or equipment damage. These instructions indicate the level of potential hazard with the labels of “**Caution**,” “**Warning**” or “**Danger**.” They are all important notes for safety and must be followed in addition to International Standards (ISO/IEC)*1), and other safety regulations.

*1) ISO 4414: Pneumatic fluid power - General rules and safety requirements for systems and their components
ISO 4413: Hydraulic fluid power - General rules and safety requirements for systems and their components
IEC 60204-1: Safety of machinery - Electrical equipment of machines - Part 1: General requirements
ISO 10218-1: Robots and robotic devices - Safety requirements for industrial robots - Part 1: Robots
etc.



Danger

Danger indicates a hazard with a high level of risk which, if not avoided, will result in death or serious injury.



Warning

Warning indicates a hazard with a medium level of risk which, if not avoided, could result in death or serious injury.



Caution

Caution indicates a hazard with a low level of risk which, if not avoided, could result in minor or moderate injury.

Warning

1. The compatibility of the product is the responsibility of the person who designs the equipment or decides its specifications.

Since the product specified here is used under various operating conditions, its compatibility with specific equipment must be decided by the person who designs the equipment or decides its specifications based on necessary analysis and test results. The expected performance and safety assurance of the equipment will be the responsibility of the person who has determined its compatibility with the product. This person should also continuously review all specifications of the product referring to its latest catalog information, with a view to giving due consideration to any possibility of equipment failure when configuring the equipment.

2. Only personnel with appropriate training should operate machinery and equipment.

The product specified here may become unsafe if handled incorrectly. The assembly, operation and maintenance of machines or equipment including our products must be performed by an operator who is appropriately trained and experienced.

3. Do not service or attempt to remove product and machinery/equipment until safety is confirmed.

1. The inspection and maintenance of machinery/equipment should only be performed after measures to prevent falling or runaway of the driven objects have been confirmed.
2. When the product is to be removed, confirm that the safety measures as mentioned above are implemented and the power from any appropriate source is cut, and read and understand the specific product precautions of all relevant products carefully.
3. Before machinery/equipment is restarted, take measures to prevent unexpected operation and malfunction.

4. Our products cannot be used beyond their specifications. Our products are not developed, designed, and manufactured to be used under the following conditions or environments. Use under such conditions or environments is not covered.

1. Conditions and environments outside of the given specifications, or use outdoors or in a place exposed to direct sunlight.
2. Use for nuclear power, railways, aviation, space equipment, ships, vehicles, military application, equipment affecting human life, body, and property, fuel equipment, entertainment equipment, emergency shut-off circuits, press clutches, brake circuits, safety equipment, etc., and use for applications that do not conform to standard specifications such as catalogs and operation manuals.
3. Use for interlock circuits, except for use with double interlock such as installing a mechanical protection function in case of failure. Please periodically inspect the product to confirm that the product is operating properly.



Safety Instructions

Caution

We develop, design, and manufacture our products to be used for automatic control equipment, and provide them for peaceful use in manufacturing industries.

Use in non-manufacturing industries is not covered.

Products we manufacture and sell cannot be used for the purpose of transactions or certification specified in the Measurement Act.

The new Measurement Act prohibits use of any unit other than SI units in Japan.

Limited warranty and Disclaimer/Compliance Requirements

The product used is subject to the following “Limited warranty and Disclaimer” and “Compliance Requirements”. Read and accept them before using the product.

Limited warranty and Disclaimer

1. The warranty period of the product is 1 year in service or 1.5 years after the product is delivered, whichever is first.*2)
Also, the product may have specified durability, running distance or replacement parts. Please consult your nearest sales branch.
2. For any failure or damage reported within the warranty period which is clearly our responsibility, a replacement product or necessary parts will be provided.
This limited warranty applies only to our product independently, and not to any other damage incurred due to the failure of the product.
3. Prior to using SMC products, please read and understand the warranty terms and disclaimers noted in the specified catalog for the particular products.

***2) Vacuum pads are excluded from this 1 year warranty.**

A vacuum pad is a consumable part, so it is warranted for a year after it is delivered.

Also, even within the warranty period, the wear of a product due to the use of the vacuum pad or failure due to the deterioration of rubber material are not covered by the limited warranty

Compliance Requirements

1. The use of SMC products with production equipment for the manufacture of weapons of mass destruction (WMD) or any other weapon is strictly prohibited.
2. The exports of SMC products or technology from one country to another are governed by the relevant security laws and regulations of the countries involved in the transaction. Prior to the shipment of a SMC product to another country, assure that all local rules governing that export are known and followed.

Precautions for design

WARNING

- ① If no leakage is allowed due to the environment, it cannot be used. Or operating fluid is not air, it cannot be used.
- ② Organic solvents including thinner, acetone, alcohol and ethylene chloride; chemicals including sulphuric acid, nitric acid and hydrochloric acid; cutting oil, synthetic oils, ester-based compressor oil, alkali, kerosene, gasoline, lock material of screw are harmful. Do not use the product where these are present.
- ③ Shield from ultra violet light and radiation with protective cover.
- ④ A safety device needs to be installed if output pressure is exceeding the set pressure, otherwise this can cause breakage of outlet device and equipment or malfunction.

CAUTION

- ① The use outside specifications is prohibited.
- ② Air consumption from the relieving port is allowed to be 0.1L/min(ANR) or less.

Selection

WARNING

- ① Grease used for internal sliding surface and packing may leak to the outlet.
- ② Residual pressure of product without backflow function is released unstably even though the inlet pressure is released (residual pressure might be left in the product).
- ③ Long absence of operation or operation with outlet circuit sealed or balance circuit may cause pressure fluctuation in outlet set pressure.
- ④ Set pressure of outlet pressure shall be 85% or less of inlet pressure. Pressure over 85% makes operation susceptible to flow and inlet pressure which lead to cause unstable operation.
- ⑤ Maximum set pressure range in the spec. has margin. Pressure set may be higher than the maximum value.
- ⑥ Cannot be used in circuits that requires high exhaust sensitivity or set precision.
- ⑦ N.C. type auto drain should be use 0.15MPa or more to avoid operating failure.

Installation

CAUTION

- ① Connect the product ensuring the direction of "IN" and "OUT" for air direction and indicated arrow. Incorrect connections may cause malfunction.
- ② Install vertically so that outlet of drain would turned downward. Use with the outlet of drain turned horizontal or upward causes malfunction.
- ③ Install with enough space around the product to perform regular maintenance and operation. Refer to section "9. DIMENSIONS" for necessary space.
- ④ Do not drop or apply impact during transportation or installation. Damage of products or pressure gauge can result in malfunction.
- ⑤ Do not install in areas with high humidity or high temperature. It may cause malfunction.

Adjustment

WARNING

- ① Adjust the set pressure ensuring correct inlet and outlet pressures. Turning the adjust screw excessively can cause damage to the internal parts.
- ② Use the spanner for the operation of the adjust screw. Refer to "9. DIMENSIONS" for applicable spanner.

CAUTION

- ① For the product with a pressure gauge, do not apply pressure exceeding the maximum scale of the pressure gauge in order to protect the gauge.
- ② Adjust pressure incrementally. Pressure may become lower than set pressure if adjusted by decreasing the value. Rotate the adjust screw clockwise to raise the set pressure. Counterclockwise to reduce the pressure. Moreover, lock the adjust screw with the lock nut after setting pressure.

AW30: Spanner Nominal: 10 / Recommended torque : M6 = 2.6 N·m

AW40: Spanner Nominal: 13 / Recommended torque : M8 = 6.2 N·m

- ③ Outlet pressure may rise if eliminate the inlet pressure after pressure setting and supply pressure again. The pressure becomes close to the set pressure after air is consumed in outlet.
- ④ Outlet pressure may change if uses for a long time. Please confirm set pressure regularly.

Piping



WARNING

- ① Before piping is connected, it should be thoroughly blown out with air (flushing) or washed to remove chips, cutting oil and solid foreign material from inside the pipe. Contamination of piping may cause damage or malfunction.
- ② When screwing together pipes and fittings, etc., be certain that chips from the pipe threads and sealant do not get inside the pipe. When a sealant tape is used, leave 1 thread ridge exposed at the end of the threads.
- ③ Connect piping/fittings using the recommended torque while holding the female thread side tightly. Insufficient tightening torque leads to cause of loosening or sealing failure, and excessive tightening torque leads to cause of breakage of screws. Tightening without holding female thread applies an excessive force to the piping bracket directly, leading to breakage.

Recommended torque	unit: N·m			
Thread size	1/4	3/8	1/2	3/4
Torque	8 to 12	15 to 20	20 to 25	28 to 30

- ④ Before using an SMC fitting and S coupler, please refer to "Tightening the threaded portion of the connection thread" of the Fittings & Tubing Precautions.
- ⑤ Do not apply torsion or bending moment other than the weight of the product itself. External piping needs to be supported separately as it may cause breakage. Non-flexible piping like steel tube is susceptible to excessive moment load or vibration. Insert flexible tubes to prevent this.
- ⑥ The piping for drain from N.C. type auto drain should be connected under the following requirements to avoid operating failure.
I.D. $\phi 4$ ($\phi 3/16$ ") or larger, Length 5 m (200 inch) or shorter

Air Source



WARNING

- ① Use clean air. Do not use compressed air containing chemicals, organic solvent, synthetic oil or corrosive gas as it may be cause of breakage of components or operation
- ② Air containing too much moisture may cause malfunction. Install an air drier or aftercooler before the regulator.

Maintenance



WARNING

- ① Maintenance and checks should be done by following the procedure in this operation manual. Incorrect handling of the product may cause breakage or operation failure of the equipment or device.
- ② Open and close drain cock manually. The use of tools may cause damage the drain cock.
- ③ Replace the element before 2 years passed since purchase or pressure drop from initial outlet pressure reaches 0.1MPa. Or the element is broken.
- ④ Discharge the drain in the bowl by opening drain cock before the drain level reaches element holder.



CAUTION

- ① If an emergency countermeasure is to be taken during setting failure or exhaust leakage, the internal valve seating part should be checked. If failure such as foreign matter is found, remove it before performing the emergency countermeasure.
- ② Check the element periodically and replace it with a new one if necessary. If it is found that outlet pressure drops lower than the normal condition or the flow is restricted during operation, check the condition of the element.
For the N.C. type auto drain, when there is no pressure, drain which does not operate the auto drain mechanism will remain in the bowl. It is recommended to release the residual drain manually at the end of the working day.

2. APPLICATION

This instrument aims at, eliminating excess saturated water of the air line and solid foreign matter, pressure controlling of air lines.

3. SPECIFICATIONS

Model	AW30-X2622	AW40-X2622
Port size	1/4, 3/8, 1/2	1/4, 3/8, 1/2, 3/4
Gauge port size	1/8	1/4
Fluid	Air	
Ambient and fluid temperature ^{Note)}	-40~80°C (No freezing)	
With auto drain	-5~60°C (No freezing)	
Proof pressure	3.0MPa	
With auto drain	1.5MPa	
Max. operating pressure	2.0MPa	
With auto drain	1.0MPa	
Set pressure range	0.05~0.85MPa	
Filtration	5μm	
Drain capacity	20cm ³	80cm ³
Construction	Relieving type	
Mass	1.19kg	3.40kg

Note) Packings and resin parts have been changed to special materials to be resistant under their environmental condition such as cold region and tropical region.

4. How to Order

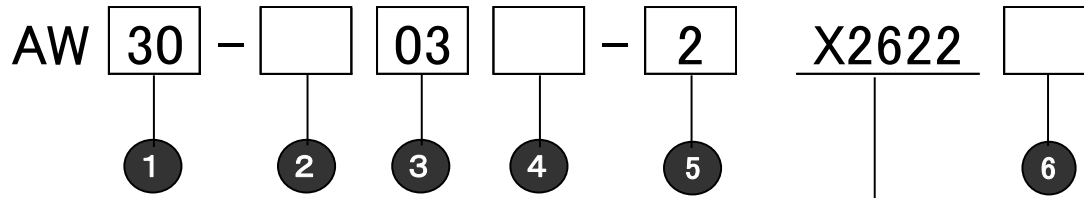

- External parts material: SUS316
- Ambient and fluid temp.: -40 to 80°C (No freezing)
(Except with auto drain)

		Symbol	Description	1	
				Body size	
				30	40
2	Thread type	Nil	Rc	●	●
		N	NPT	●	●
		F	G	●	●
		+			
3	Port size	02	1/4	●	●
		03	3/8	●	●
		04	1/2	●	●
		06	3/4	—	●
		+			
4 <small>Note1)</small>	Option a	Float type auto drain	Nil Without auto drain	●	●
			C With float type auto drain (N.C.)		
		+			
5 <small>Note1)</small> <small>Note2)</small>	Semi-standard b	Bowl	2 Metal bowl	●	●
		c	Flow direction	Nil Flow direction : Left to right	●
	R Flow direction : Right to left		●	●	
		+			
6	Option	Nil	—	●	●
		A	Round type pressure gauge (Without limit indicator) <small>Note3)</small>	●	●
		B	With bracket assembled	●	●
		C	Round type pressure gauge (Without limit indicator) <small>Note3)</small> With bracket assembled	●	●

Note 1) Select one each for a to c.

Note 2) When more than one symbol is required, indicate in numerical order, then alphabetical order.

Example) AW30-03C-2R-X2622A

Note 3) Pressure gauge included not installed.

5. TROUBLESHOOTING

Refer to "6. CONSTRUCTION/PARTS LIST" and "8. DISASSEMBLY DRAWING".

TROUBLE		POSSIBLE CAUSE	REMEDY
Demarcation	Phenomenon		
Pressure	Pressure is not regulated.	1. Opposite flow direction or opposite installation of filter regulator.	1. Check flow direction and install the filter regulator correctly if wrong.
		2. Adjust spring is damaged.	2. Replace the adjust spring.
		3. Valve spring is damaged.	3. Replace the valve spring.
		4. Foreign materials caught in valve seat or valve O ring.	4. Remove the valve assembly to clean valve, valve seat and the valve O-ring. Then, grease up the valve O-ring and the sliding surface.
		5. Valve rubber seat is damaged.	5. Replace the valve assembly.
	Set pressure does not return to zero when adjust screw is loosened.	1. Foreign materials caught in valve seat or valve O ring.	1. Remove the valve guide to clean valve, valve seat and the valve O-ring. Then, grease up the valve O-ring and the sliding surface.
		2. Valve rubber seat is damaged.	2. Replace the valve assembly.
		3. Valve spring is damaged.	3. Replace the valve spring.
4. Valve adheres to the valve guide.		4. Wash the sliding surface of valve O-ring and grease up.	
Flow rate	Large air resistance reduces flow rate.	1. Clog of the element.	1. Clean or replace the element.
Air leaks	Air leaks from the bonnet exhaust port.	1. Diaphragm is damaged.	1. Replace the diaphragm assembly.
		2. Foreign material is caught in the relieving valve seat.	2. Clean the relieving valve seat, or replace the diaphragm assembly.
		3. Foreign material is caught in the valve seat of valve O ring.	3. Remove the valve guide to clean valve, valve seat and the valve O-ring. Then, grease up the valve O-ring and the sliding surface.
		4. Valve rubber seat is damaged.	4. Replace the valve assembly.
		5. Back pressure exceeding the set pressure is applied to the outlet.	5. Revise the air circuit so that back pressure does not exceed the set pressure.
	Air leaks between the bonnet and the body.	1. Loosened bonnet.	1. Fasten the bonnet.
		2. Diaphragm is damaged.	2. Grease up before assembling.
Air leaks from the bowl and the body.	1. Breakage of bowl O ring.	1. Replace the bowl O-ring. Grease up before assembling.	
Air leaks from the bowl.	1. Breakage of bowl.	1. Replace the bowl assembly.	
Air leaks from the drain cock.	1. The foreign matter caught in the valve of the drain cock. the drain cock.	1. Open the drain cock for a few seconds for blowing.	
	2. Breakage of the seating part of the drain cock.	2. Replace the bowl assembly.	
Operational	Draining isn't perfumed though the drain cock is opened.	1. Clock of outlet of the drain cock due to solid foreign matter etc.	1. Replace the bowl assembly.
	Too much drain comes from the piping of secondary side.	1. Drain level reaches the element holder.	1. Open the drain cock for draining and replace the element.

Note) Grease pack for maintenance "GR-F-####" is recommended for use. (See table 1, table 2)

Table 1. Coating amount per unit

Model	Mass(g)
AW30	0.45
AW40	0.6

Table 2. Grease pack No.

No.	Mass(g)
GR-F-005	5
GR-F-050	50
GR-F-100	100
GR-F-200	200
GR-F-500	500

6. CONSTRUCTION/PARTS LIST

1) Construction

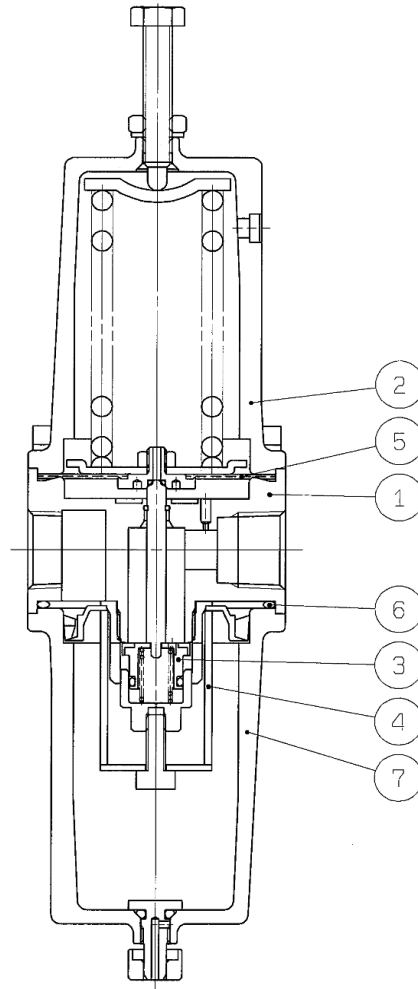

2) PARTS LIST

Component Parts

No.	Description	Material
①	Body	SCS14A (Equivalent to SUS316)
②	Bonnet	SCS14A (Equivalent to SUS316)

Option/Replacement Parts

No.	Description	Thread	Material	Part No.	
				AW30-X2622	AW40-X2622
③	Valve assembly	—	SUS316/Low-temp. NBR	AW30P-340AS-X2622	AW40P-340AS-X2622
④	Element	—	SUS316L	AF30P-060S-7-5S	AF40P-060S-7-5S
⑤	Diaphragm assembly	—	CR	AR30P-150AS-X2622	AR40P-150AS-X2622
⑥	Bowl O-ring	—	Low-temp. NBR	KA02964(45.5x2)	KA01714(66.5x2)
⑦	Bowl assembly ^{Note1)} Float type auto drain (N.C.) ^{Note1)}	—	Bowl:SCS14A (Equivalent to SUS316)	C3SF-2-X2622	C4SF-2-X2622
				AD37-2-X2622	AD47-2-X2622
				AD37N-2-X2622	AD47N-2-X2622
				AD37F-2-X2622	AD47F-2-X2622
⑧	Bracket	—	SUS316	AR30P-271-X2622	AR40P-271-X2622
⑨	Pressure gauge	Rc	—	G43-10-01-X3	G43-10-02-X3
		NPT	—	G43-10-N01-X3	G43-10-N02-X3
		G	—	G43-10-01-X3	G43-10-02-X3

Note1) Bowl assembly and Float type auto drain includes ⑥Bowl O-ring.

Note2) The number in the table is corresponding to the number in structural drawing (above-mentioned figure) and "8. DISASSEMBLY DRAWING".

7. REPLACEMENT PROCEDURE

WARNING

Before replacement, ensure that the filter regulator is not pressurized.

Also, make sure to loosen the pressure adjust screw so that the set pressure is zero.

Replace referring to "8. DISASSEMBLY DRAWING".

After replacement, ensure that specified function is satisfied and external leakage is not found before starting operation.

1) Bowl assembly/element

Process	Procedure	Tools	Check item									
Disassembly	1) Remove the bowl assembly. The bolts (4 pcs) and the spring washers (4 pcs) are removed.	Hexagon wrench Nominal: <table border="1"><tr><td>AW30</td><td>3</td></tr><tr><td>AW40</td><td>5</td></tr></table>	AW30	3	AW40	5	—					
	AW30	3										
AW40	5											
2) Remove the element. Rotate the bolt for fixing element counterclockwise, and element holder, element, and deflector are removed.	Hexagon wrench Nominal: 3	—										
Assembly	3) Mount the element. Mount parts to the body in order of deflector, element, and element holder. And, install it with the bolt for fixing element.	Hexagon wrench Nominal: 3	Tightening torque 0.76±0.08N·m									
	4) Mount the bowl assembly. Mount the bowl to the body, and settle it temporary with bolts (4 pcs) with a hexagon wrench. Then, tighten bolts diagonally with the tightening torque in the check item to settle.	Hexagon wrench Nominal: <table border="1"><tr><td>AW30</td><td>3</td></tr><tr><td>AW40</td><td>5</td></tr></table>	AW30	3	AW40	5	<table border="1"><tr><td colspan="2">Tightening torque</td></tr><tr><td>AW30</td><td>2.35±0.3N·m</td></tr><tr><td>AW40</td><td>4.5±1N·m</td></tr></table>	Tightening torque		AW30	2.35±0.3N·m	AW40
AW30	3											
AW40	5											
Tightening torque												
AW30	2.35±0.3N·m											
AW40	4.5±1N·m											

2) Diaphragm assembly

Process	Procedure	Tool	Check item									
Disassembly	1) Remove the bonnet. The bolts (4 pcs) and the spring washers (4 pcs) are removed.	Hexagon wrench Nominal: <table border="1"><tr><td>AW30</td><td>3</td></tr><tr><td>AW40</td><td>5</td></tr></table>	AW30	3	AW40	5	—					
	AW30	3										
AW40	5											
2) Remove parts in order of the adjusting spring holder, adjust spring, and the diaphragm assembly.	—	—										
Assembly	3) Mount parts to the body in order of the diaphragm assembly, adjust spring, and adjust spring holder. Mind the direction of the adjust spring holder. See attached "8. disassembly drawing".	—	Direction of adjust spring holder									
	4) Mount the bonnet to the body. Turn the convex part of the bonnet (relief port side) to out port side. Mount the bonnet to the body, and settle it temporary with bolts (4 pcs) with a hexagon wrench. Then, tighten bolts diagonally with the tightening torque in the check item to settle.	Hexagon wrench Nominal: <table border="1"><tr><td>AW30</td><td>3</td></tr><tr><td>AW40</td><td>5</td></tr></table>	AW30	3	AW40	5	<table border="1"><tr><td colspan="2">Tightening torque</td></tr><tr><td>AW30</td><td>2.35±0.3N·m</td></tr><tr><td>AW40</td><td>4.5±1N·m</td></tr></table>	Tightening torque		AW30	2.35±0.3N·m	AW40
AW30	3											
AW40	5											
Tightening torque												
AW30	2.35±0.3N·m											
AW40	4.5±1N·m											

3) Valve assembly

Process	Procedure	Tools	Check item					
Disassembly	1) Remove valve guid after removing bowl assembly and element. After removing the bowl assembly and element, hold the valve guide with a spanner to rotate it counterclockwise and remove the valve guide.	Spanner Nominal : 7	—					
	2) Remove the valve spring.	—	—					
	3) Remove the valve assembly.	—	—					
Assembly	4) Mount the valve assembly. Mate the stem convex and the valve center hole.	—	Positioning the stem and the valve (centering)					
	5) Mount the valve spring. Insert the valve spring to the valve hole.	—	—					
	6) Mount the valve guide. Hold the valve guide with a spanner to rotate it clockwise and mount the valve guide. See check item for the tightening torque.	Spanner Nominal : 7	<table border="1"> <tr> <td colspan="2">Tightening torque</td> </tr> <tr> <td>AW30</td> <td>2.35±0.3N·m</td> </tr> <tr> <td>AW40</td> <td>4.5±1N·m</td> </tr> </table>	Tightening torque		AW30	2.35±0.3N·m	AW40
Tightening torque								
AW30	2.35±0.3N·m							
AW40	4.5±1N·m							

4) Bracket

Process	Procedure	Tools	Check items					
Assembly	1) Remove the bolts (2 pcs) and the spring washers (2 pcs) of the product back side by rotating counterclockwise.	Hexagon wrench Nominal : AW30 3 AW40 5	—					
	2) Mount the bracket on the product. Then, install the bolts (2 pcs) and the spring washers (2 pcs) remove at 1). Refer to "8. DISASSEMBLY DRAWING 2) Bracket Disassembly drawing".	Hexagon wrench Nominal : AW30 3 AW40 5	<table border="1"> <tr> <td colspan="2">Tightening torque :</td> </tr> <tr> <td>AW30</td> <td>2.35±0.3N·m</td> </tr> <tr> <td>AW40</td> <td>4.5±1N·m</td> </tr> </table>	Tightening torque :		AW30	2.35±0.3N·m	AW40
Tightening torque :								
AW30	2.35±0.3N·m							
AW40	4.5±1N·m							

5) Round type pressure gauge

Process	Procedure	Tools	Check item					
Disassembly	1) Remove the pressure gauge. Hold the width across flats of the pressure gauge with a spanner. Then, rotate counterclockwise to remove.	Spanner Nominal : 14	—					
Assembly	2) Rap the pressure gauge thread with the seal tape leaving 1 threads from the end.	—	Wrap seal tape leaving 1 threads					
	3) Mount the pressure gauge. Hold the width across flats of the pressure gauge with a spanner. Then, rotate clockwise to mount. See Check item for tightening torque of pressure gauge.	Spanner Nominal : 14	<table border="1"> <tr> <td colspan="2">Tightening torque :</td> </tr> <tr> <td>AW30</td> <td>3 to 5N·m</td> </tr> <tr> <td>AW40</td> <td>8 to 12N·m</td> </tr> </table>	Tightening torque :		AW30	3 to 5N·m	AW40
Tightening torque :								
AW30	3 to 5N·m							
AW40	8 to 12N·m							

8. DISASSEMBLY DRAWING

1) Product Disassembly drawing

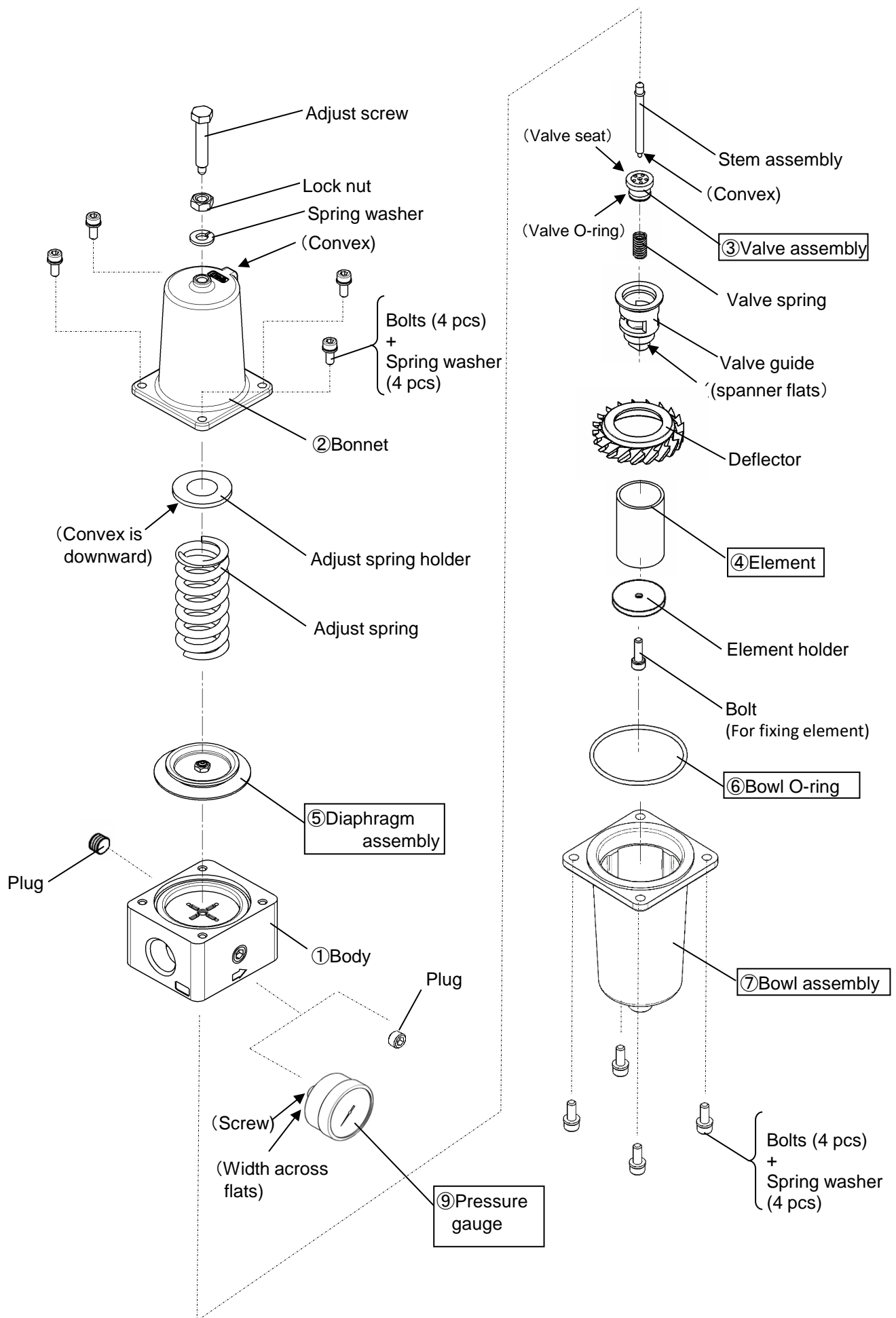

2) Bracket Disassembly drawing

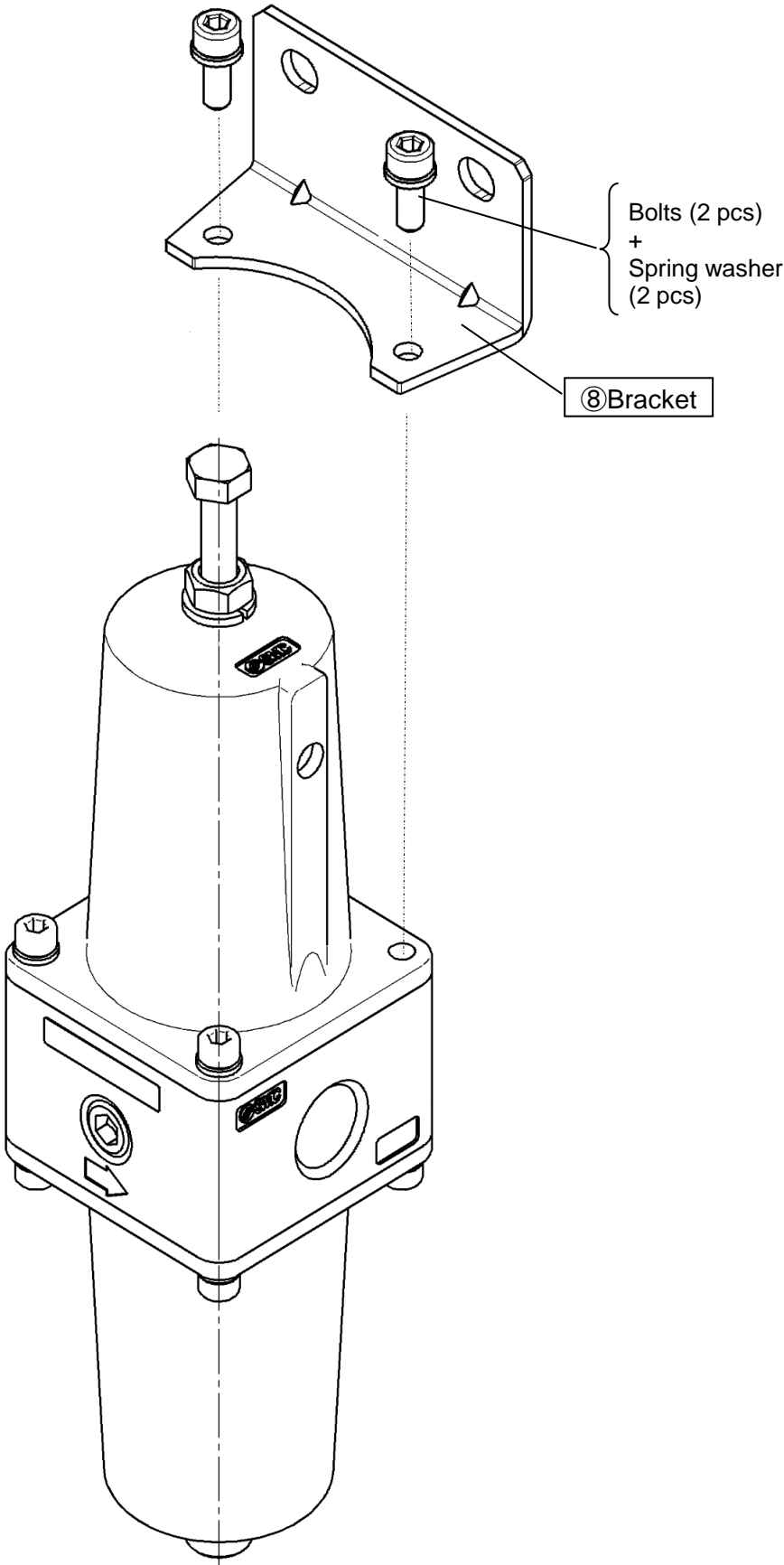

9. DIMENSIONS

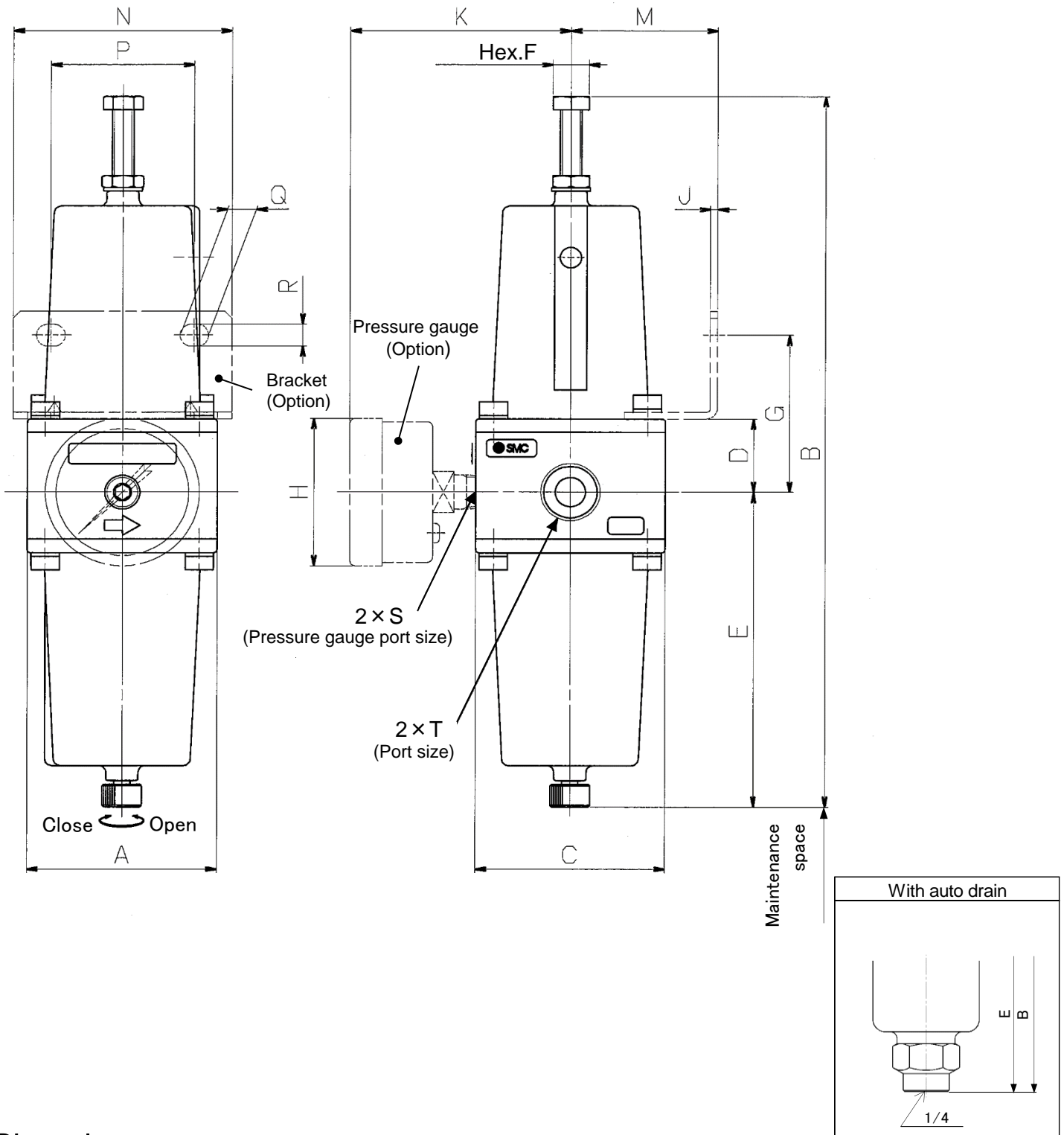

Dimensions

Model	T	S	A	B	C	D	E	F	G	H	J	K	M
AW30-X2622	1/4, 3/8, 1/2	1/8	53	207.7	53	21.1	92.1	10	45.7	φ 43	2	65.5	40.5
AW40-X2622	1/4, 3/8, 1/2, 3/4	1/4	75	334	72	29.8	146	13	56	φ 43	2.5	75	50

Model	N	P	Q	R	With auto drain		Maintenance space
					B	E	
AW30-X2622	61	40	8	6.5	250.1	134.5	40
AW40-X2622	80	54	10.5	8.5	361.6	173.4	70

Revision history

A: Added note ④ of "piping". Corrected tightening torque (Bonnet and bowl mounting screw). Renewal of external dimensions.	July 2019
B: Add: Applicable part number(AW30-04-X2622) Note for auto drain, Grease pack No. Change: "Safety Instructions"(P2,3) Recommended tightening torque Format change: "How to Order"	Mar. 2024

SMC Corporation

Tel: + 81 3 5207 8249 Fax: +81 3 5298 5362
URL <https://www.smcworld.com>