



Operation Manual

PRODUCT NAME

Speed Controller Standard Type
Elbow Type (Metal Body)

MODEL / Series / Product Number

AS1400-M3
AS12*0~AS42*0

SMC Corporation

Contents

1. Safety Instructions	2 ~ 3
2. Specific Product Precautions	4 ~ 6
3. Application	7
4. Specifications	7
5. Troubleshooting	7
6. Construction	8



Speed Controller Standard Type Elbow Type (Metal Body) / AS Series Safety Instructions

These safety instructions are intended to prevent hazardous situations and/or equipment damage. These instructions indicate the level of potential hazard with the labels of “**Caution**,” “**Warning**” or “**Danger**.” They are all important notes for safety and must be followed in addition to International Standards (ISO/IEC)^{*)}, and other safety regulations.

*1) ISO 4414: Pneumatic fluid power - General rules and safety requirements for systems and their components
ISO 4413: Hydraulic fluid power - General rules and safety requirements for systems and their components
IEC 60204-1: Safety of machinery - Electrical equipment of machines - Part 1: General requirements
ISO 10218-1: Robots and robotic devices - Safety requirements for industrial robots - Part 1: Robots
etc.



Danger

Danger indicates a hazard with a high level of risk which, if not avoided, will result in death or serious injury.



Warning

Warning indicates a hazard with a medium level of risk which, if not avoided, could result in death or serious injury.



Caution

Caution indicates a hazard with a low level of risk which, if not avoided, could result in minor or moderate injury.



Warning

1. The compatibility of the product is the responsibility of the person who designs the equipment or decides its specifications.

Since the product specified here is used under various operating conditions, its compatibility with specific equipment must be decided by the person who designs the equipment or decides its specifications based on necessary analysis and test results. The expected performance and safety assurance of the equipment will be the responsibility of the person who has determined its compatibility with the product. This person should also continuously review all specifications of the product referring to its latest catalog information, with a view to giving due consideration to any possibility of equipment failure when configuring the equipment.

2. Only personnel with appropriate training should operate machinery and equipment.

The product specified here may become unsafe if handled incorrectly. The assembly, operation and maintenance of machines or equipment including our products must be performed by an operator who is appropriately trained and experienced.

3. Do not service or attempt to remove product and machinery/equipment until safety is confirmed.

1. The inspection and maintenance of machinery/equipment should only be performed after measures to prevent falling or runaway of the driven objects have been confirmed.
2. When the product is to be removed, confirm that the safety measures as mentioned above are implemented and the power from any appropriate source is cut, and read and understand the specific product precautions of all relevant products carefully.
3. Before machinery/equipment is restarted, take measures to prevent unexpected operation and malfunction.

4. Our products cannot be used beyond their specifications. Our products are not developed, designed, and manufactured to be used under the following conditions or environments. Use under such conditions or environments is not covered.

1. Conditions and environments outside of the given specifications, or use outdoors or in a place exposed to direct sunlight.
2. Use for nuclear power, railways, aviation, space equipment, ships, vehicles, military application, equipment affecting human life, body, and property, fuel equipment, entertainment equipment, emergency shut-off circuits, press clutches, brake circuits, safety equipment, etc., and use for applications that do not conform to standard specifications such as catalogs and operation manuals.
3. Use for interlock circuits, except for use with double interlock such as installing a mechanical protection function in case of failure. Please periodically inspect the product to confirm that the product is operating properly.



Speed Controller Standard Type Elbow Type (Metal Body) / AS Series Safety Instructions

Caution

We develop, design, and manufacture our products to be used for automatic control equipment, and provide them for peaceful use in manufacturing industries.

Use in non-manufacturing industries is not covered.

Products we manufacture and sell cannot be used for the purpose of transactions or certification specified in the Measurement Act.

The new Measurement Act prohibits use of any unit other than SI units in Japan.

Limited warranty and Disclaimer/Compliance Requirements

The product used is subject to the following “Limited warranty and Disclaimer” and “Compliance Requirements”. Read and accept them before using the product.

Limited warranty and Disclaimer

1. The warranty period of the product is 1 year in service or 1.5 years after the product is delivered, whichever is first.*2)

Also, the product may have specified durability, running distance or replacement parts. Please consult your nearest sales branch.

2. For any failure or damage reported within the warranty period which is clearly our responsibility, a replacement product or necessary parts will be provided.

This limited warranty applies only to our product independently, and not to any other damage incurred due to the failure of the product.

3. Prior to using SMC products, please read and understand the warranty terms and disclaimers noted in the specified catalog for the particular products.

***2) Vacuum pads are excluded from this 1 year warranty.**

A vacuum pad is a consumable part, so it is warranted for a year after it is delivered.

Also, even within the warranty period, the wear of a product due to the use of the vacuum pad or failure due to the deterioration of rubber material are not covered by the limited warranty

Compliance Requirements

1. The use of SMC products with production equipment for the manufacture of weapons of mass destruction (WMD) or any other weapon is strictly prohibited.

2. The exports of SMC products or technology from one country to another are governed by the relevant security laws and regulations of the countries involved in the transaction. Prior to the shipment of a SMC product to another country, assure that all local rules governing that export are known and followed.

2. Specific Product Precautions

Design/ Selection

Warning

(1) Confirm the specifications.

Do not operate at pressures, temperatures, etc., beyond the range of specifications, as this can cause damage or malfunction. (Refer to the specifications.)

We do not guarantee against any damage if the product is used outside of the specifications range.

(2) Products mentioned in this catalog are not designed for use as stop valves with zero air leakage.

A certain amount of leakage is allowed in the products specifications. Tightening the needle to reduce leakage to zero may result in equipment damage.

(3) Do not disassemble the product or make any modifications, including additional machining.

Doing so may cause human injury and/or an accident.

(4) The flow rate characteristics for each product are representative values.

The flow rate characteristics are characteristics of each individual product. Actual values may differ depending on the piping, circuitry, pressure conditions, etc. Also, depending on product specifications, there may be variations in the zero needle rotations position of the flow rate characteristics.

(5) Check if that PTFE can be used in application.

PTFE powder (Polytetrafluoroethylene resin) is included in the seal material for piping taper thread of male thread type. Confirm that the use of it will not cause any adverse effect on the system.

Please contact SMC if the Safety Data Sheet (SDS) is required.

Mounting

Warning

(1) Operation Manual

Install the products and operate it only after reading the operation manual carefully and understanding its contents. Also, keep the manual where it can be referred to as necessary.

Mounting

Warning

(2) Ensure sufficient space for maintenance activities.

When installing the products, allow access for maintenance.

(3) Confirm that the lock nut is tightened.

A loose lock nut may cause speed changes in the actuator.

(4) Check the degree of rotation of the needle valve.

The Products in this catalog are retainer type so that the needle is not removed completely. Over rotation will cause damage.

(5) Do not use tools such as pliers to rotate the knob.

This can cause idle rotation of the knob or damage.

(6) Confirm the air flow direction.

Mounting backward is dangerous, because the speed adjustment needle will not work and the actuator may lurch suddenly.

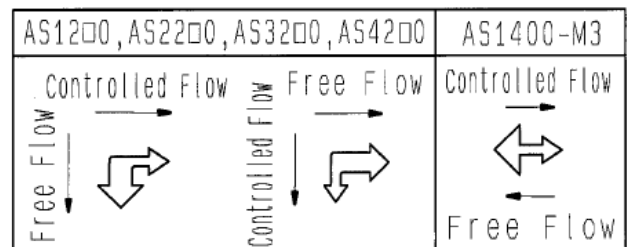

(7) Adjust the needle by opening the needle slowly after having closed it completely.

Loose needle valves may cause unexpected sudden actuator lurching.

When a needle valve is turned clockwise, it is closed and cylinder speed decreases. When a needle valve is turned counterclockwise, it is open and cylinder speed increases.

(8) Do not apply excessive force or shock to the body or fittings with an impact tool.

This can cause damage or air leakage.

(9) Tighten threads with the proper tightening torque.

When installing the products, follow the listed proper torque.

(10) For installation/removal, please tighten the hexagonal width across flats of Body B (AS1400-M3: joint) with an appropriate spanner.

Do not apply torque at other points as the product may be damaged. For AS22*0 ~ AS42*0, the Body A can be rotated after installation.

Mounting

Caution

(1) Tightening method

The proper tightening torques of the fitting are as shown in the table below. As a guide, tighten by hand, then turn it two or three turns with a wrench. Pay attention not to over tighten the product. Check the dimensions of each product for the hexagon width across flats.

Connection thread size	Tightening rotate value after hand-tightening	[Reference value] Tightening torque N · m
M3	1/4 turn ^{Note1)}	0.4 to 0.5
M5 10/32-UNF	1/6 turn	1 to 1.5
1/8	2 to 3 turn	3 to 5
1/4	2 to 3 turn	8 to 12
3/8	2 to 3 turn	15 to 20
1/2	2 to 3 turn	20 to 25

Note1) AS1400-M3 is 1/2 turn after hand-tightening.

- (2) The proper tightening torques for hexagon lock nuts are shown in the table below. For standard installation, turn 15 to 30° using a tool after fastening by hand. Pay attention not to over tighten the product. Check the dimensions for each product for the width across flats.**

Model Number	Proper tightening torque (N · m)	Lock nut width across flats
AS1200-M3 AS1400-M3	0.07	4.5
AS12□0-M5	0.3	7
AS22□0-01	1	10
AS22□0-02	1.2	12
AS32□0	2	14
AS42□0	6	17

Piping

Caution

- (1) Refer to the Fittings & Tubing Precautions for handling One-touch fittings.**

(2) Preparation before piping

Before piping is connected, it should be thoroughly blown out with air (flushing) or washed to remove chips, cutting oil and other debris from inside the pipe.

(3) Winding of sealant tape

When screwing together pipes and fittings, etc., be certain that chips from the pipe threads and sealing material do not get inside the pipe. Also, when the sealant tape is used, leave approx. 1 thread ridges exposed at the end of the threads.

Air Supply

Warning

(1) Type of fluids

Use compressed air as the fluid used.

(2) When there is a large amount of drainage

Compressed air containing a large amount of drainage can cause the malfunction of pneumatic equipment. An air dryer or water separator should be installed upstream from filters.

(3) Drain flushing

If condensation in the drain bowl is not emptied on a regular basis, the bowl will overflow and allow the condensation to enter the compressed air lines. This causes the malfunction of pneumatic equipment.

If the drain bowl is difficult to check and remove, the installation of a drain bowl with an auto drain option is recommended.

For compressed air quality, refer to SMC catalog "Compressed Air Purification System".

(4) Use clean air

Do not use compressed air that contains chemicals, synthetic oils that include organic solvents, salt, corrosive gases, etc., as it can cause damage or malfunction.

Caution

(1) Install an air filter.

Install an air filter upstream near the valve. Select an air filter with a filtration size of 5µm or smaller.

(2) Take measures to ensure air quality, such as by installing an aftercooler, air dryer, or water separator.

Compressed air that contains a large amount of drainage can cause the malfunction of pneumatic equipment, such as flow control equipment. Therefore, take appropriate measures to ensure air quality, such as by providing an aftercooler, air dryer, or water separator.

(3) Ensure that the fluid and ambient temperatures are within the specified range.

If the fluid temperature is 5°C or less, the moisture in the circuit could freeze, causing damage to the seals or leading to equipment malfunction. Therefore, take appropriate measures to prevent freezing.

For compressed air quality, refer to SMC catalog "Compressed Air Purification System".

Operating environment

Warning

- (1) **Do not use in an atmosphere containing corrosive gases, chemicals, sea water, water, water steam, or where there is direct contact with any of these.**

Refer to each construction drawing for information on the materials of flow control equipment.

- (2) **Do not expose the product to direct sunlight for an extended period of time.**
- (3) **Do not use in a place subject to heavy vibration and/or shock.**
- (4) **Do not mount the product in locations where it is exposed to radiant heat.**

Maintenance

Warning

- (1) **Perform maintenance and inspection according to the procedures indicated in the operation manual.**

If handled improperly, malfunction or damage of machinery and equipment may occur.

- (2) **Maintenance work**

If handled improperly, compressed air can be dangerous.

Assembly, handling, repair and element replacement of pneumatic systems should be performed by a knowledgeable and experienced person.

- (3) **Drain flushing**

Remove drainage from air filters regularly.

- (4) **Removal of equipment, and supply/exhaust of compressed air**

Before components are removed, first confirm that measures are in place to prevent workpieces from dropping, run-away equipment, etc.

Then, Cut the supply pressure and electric power, and exhaust all compressed air from the system using the residual pressure release function.

When machinery is restarted, proceed with caution after confirming that appropriate measures are in place to prevent sudden movement.

3. Application

This product is designed to control the speed of a pneumatic actuator.

4. Specifications

Proof pressure	1.5 Mpa ^{Note1)}
Max. operating pressure	1 Mpa ^{Note2)}
Min. operating pressure	0.1 Mpa
Ambient and fluid temperature	-5 to 60°C (No freezing)
Needle rotate value	10 turns (M5: 8 turns)

Note1) AS1200-M3,AS1400-M3 : 1.05MPa.

Note2) AS1200-M3,AS1400-M3 : 0.7MPa.

5. Troubleshooting

Trouble	Possible causes	Countemeasures
The speed (flow rate) cannot be adjusting.	The direction of check valve is reversed.	Confirm which control is used meter-out or meter-in in accordance with operating conditions.
	There are some dust inside.	Lock nut : is silver→open a needle to its full width, and flush (air blow) from the one touch fitting. Lock nut : is black→open a needle to its full width, and flush (air blow) from the male thread.

6. Construction

AS1400-M3

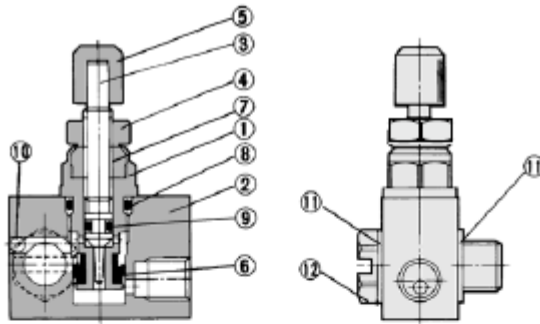

Component Parts

No.	Description	Material	Note
1	Body B	Brass	Electroless nickel plated
2	Body A	Brass	Electroless nickel plated
3	Needle	Brass	Electroless nickel plated
4	Lock nut	Steel ⁽¹⁾	Zinc chromated ⁽¹⁾
5	Handle	Brass	Electroless nickel plated
6	U seal	HNBR	
7	Needle guide	Brass	Electroless nickel plated
8	O-ring	NBR	
9	O-ring	NBR	
10	Steel ball	Chromium bearing steel	
11	Gasket	PVC	
12	Joint	Brass	Electroless nickel plated

Note 1) The material and surface treatment of the lock nut option-J (round type) is brass and electroless nickel plating, respectively.

Meter-out type

AS1200-M3, M5, U10/32

AS2200, 3200, 4200

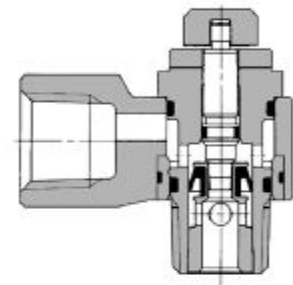
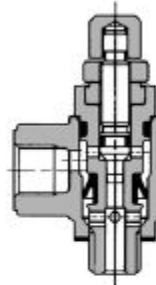
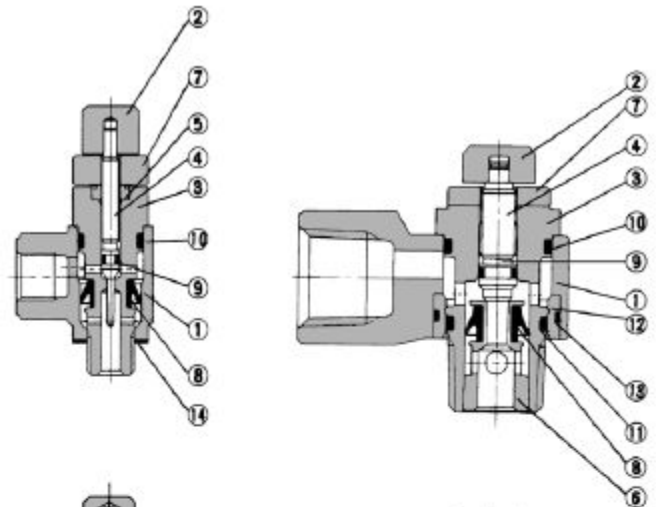

Meter-in type

AS1210-M5, U10/32

AS2210, 3210, 4210

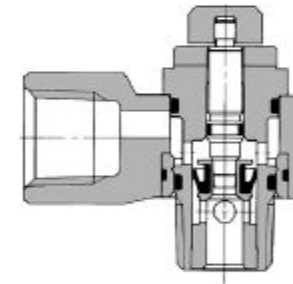
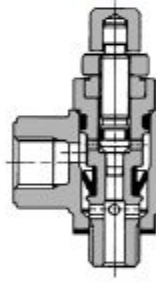

Component Parts

No.	Description	Material	Note
1	Body A	Zinc alloy	
2	Handle	Brass	Electroless nickel plated
3	Body B	Brass	Electroless nickel plated
4	Needle	Brass	Electroless nickel plated
5	Needle guide	Brass	Electroless nickel plated
6	Seat ring	Brass	Electroless nickel plated ⁽¹⁾
7	Lock nut	Steel ⁽²⁾	Meter-out Zinc chromate plated ⁽³⁾
			Meter-in Black zinc chromate plated
8	U seal	HNBR	
9	O-ring	NBR	
10	O-ring	NBR	
11	O-ring	NBR	
12	Bushing	PBT	01 to 04 type
13	O-ring		01 to 04 type
		PVC	M3 type
14	Gasket	NBR, Stainless steel	M5, U10/32 type

Note 1) For the AS4200 type only, the electroless nickel plating specification is available for option N.
 Note 2) The material of the lock nut option-J (round type) is brass. However, note that only the AS2200 uses steel.

Note 3) The surface treatment of the lock nut option-J (round type) is electroless nickel plated.

Revision history
B: Delete SMC address. "Safety Instruction" changed.

SMC Corporation

Tel: + 81 3 5207 8249 Fax: +81 3 5298 5362

URL <https://www.smeworld.com>

Note: Specifications are subject to change without prior notice and any obligation on the part of the manufacturer.
© SMC Corporation All Rights Reserved