



OPERATION MANUAL

PRODUCT NAME: REGULATOR

MODEL : ARX20-01~02

ARX21-01~02

- READ THIS OPERATION MANUAL CAREFULLY BEFORE USE IT.
- NEVER INSTALL THE PRODUCT UNTIL FINISH READING THIS MANUAL.
- KEEP THIS MANUAL ALL THE TIME FOR YOUR REFERENCE.

SMC CORPORATION

CONTENTS

1. PRECAUTIONS FOR SAFETY.....	1~4
2. PURPOSE.....	5
3. SPECIFICATIONS.....	5
4. HOW TO ORDER.....	5
5. TROUBLESHOOTING.....	6
6. CONSTRUCTION/PARTS LIST.....	7
7. SPARE PARTS.....	7

CONTACT ADDRESS: SMC CORPORATION

AKIHABARAUDX 15F, 4-14-1, SOTOKANDA, CHIYODA-KU, TOKYO
101-0021, JAPAN
TEL: 03-5207-8271

1. PRECAUTIONS FOR SAFETY

Precautions shown here are to ensure the product is used correctly and safely, and to prevent hazard and damage inflicting upon people from occurring. These precautions are divided into three categories, " Caution ", " Warning ", and " Danger " to indicate the degree of possible hazard and damage, and of urgency.

As all these are important for safety, never fail to follow them in addition of ISO4414, JIS B8370, and other safety regulations.

 Caution : Possible harmful effects are expected to be on people and possible loss is expected only of objects when wrong operation occurred.

 Warning : Possible loss or serious injury of people is expected when wrong operation occurred.

 Danger : Imminent danger that possible loss or serious injury of people is expected without evacuation.

*1 : ISO 4414 : Pneumatic fluid power-Recommendations for the application of equipment to transmission and control systems.

*2 : JIS B 8370 : Common regulations for pneumatic systems.

⚠ Warning

- ① Suitability of pneumatic equipment should be determined by a designer of the pneumatic system or a person who prescribes its specifications.

Since the product shown here is used in various operating conditions, its suitability to a system should be determined by the pneumatic system designer or the person prescribes its specifications based on necessary analyses and tests. The person who determined the suitability of the system is responsible for the performance at a certain point of time and safety assurance of this system. A system should be constructed by referring to the latest product information and catalogues, discussing all the contents of specifications, and considering possibilities of equipment failure.

- ② Equipment should be handled by those who have sufficient knowledge and experience.

Compressed air fluid could be hazardous if it is handled incorrectly. Assembly, operation and maintenance of machinery and equipment for which pneumatic apparatuses are used should be performed by those who have sufficient knowledge and experience.

- ③ Never handle the machinery or equipment, or never take out the apparatuses until safety is confirmed.

- a. Check and maintenance of machinery or equipment should be performed after it is confirmed that dropping or uncontrollable running prevention measures are taken for the equipment on which the product is mounted.
- b. Apparatuses should be taken out after it is confirmed equipment corresponding to air supply, that is an energy source, should be turned off ; and compressed air in the system should be exhausted.
- c. Re-starting of machinery or equipment should be done with ample care after it is confirmed that prevention measures for sudden movement are taken.

- ④ When the product is used in the following conditions or environment, considerations for safety measures should be given along with consultation to our company.

- a. Outdoor usage, or usage in conditions or environment outside of the specifications indicated.
- b. Usage for nuclear power, railroad, air navigation, vehicle, medical equipment, appliances contacting food and beverage, entertainment apparatuses, emergency shutdown circuits, clutch/break circuits for pressing, and safety devices.
- c. Usage for applications which especially require safety because considerable effects to people and properties are expected.

DESIGN • SELECTION

⚠ Warning

- ① Confirm specifications.

Products presented in this catalog are designed to be used in compressed air system only. Do not use them out of the specified ranges of pressure and temperature, otherwise breakdown or malfunction may occur.

- ② Confirm setting pressure range.

make sure to attach a safety device where output pressure beyond the setting pressure range may result in breakdown or malfunction at the outlet side.

- ③ Release residual pressure.

Secondary pressure may remain as releasing primary pressure at low secondary Pressure setting. Provide a residual pressure releasing circuit for secure Secondary pressure removal.

- ④ Contact SMC for use in a secondary closed circuit or balance circuit.

- ⑤ Set secondary pressure range 85% or less of maximum setting pressure and primary Pressure so as not to increase pressure drop.

INSTALLATION

⚠ Warning

- ① Mount a product with a good understanding of its operation manual.

Keep the manual handy so that it can be referred if necessary.

- ② Ensure space needed for maintenance.

- ③ Strictly follow tightening torque specification.

PT, NPT, PF	Recommended tightening Torque
1/6	7 to 9 N · m
1/4	12 to 14 N · m

⚠ Caution

- ④ For proper pressure setting,

- 1) set pressure upward and lock the handle when setting is completed and
- 2) confirm "SUP" mark indicating the air supply port.

PIPING

⚠ Caution

- ① Before piping

Thoroughly air blow (flush) or wash pipes to remove chips, cutting oil and dust Before piping.

- ② Sealant tape

When pipes and fittings are screwed in, avoid chips from thread or sealant entering Piping. Leave 1.5 to 2 threads uncovered on the tip when applying sealant tape.

AIR SUPPLY

⚠ Warning

- ① Operating fluid
Contact SMC if other fluid than compressed air is used for operation.
- ② Air quality
Use clean air. Compressed air containing chemicals, synthetic oil with organic Solvents, salinity, corrosive gases and other impurities may result in breakage Or malfunction.

ENVIRONMENT

⚠ Warning

- ① Do not use a product in an environment where it is directly exposed to corrosive Gases, chemicals, salt water, water or steam.
- ② Shut down direct sunlight in a place where a product is exposed to it.
- ③ Do not mount a product in a location where there is strong vibration and/or shock.
- ④ Do not use a product in a place where it is exposed to radiant heat from heat Source closely located.

MAINTENANCE

⚠ Warning

- ① Maintenance work
Compressed air can be dangerous when wrongly handled. Follow specifications, and Only allow qualified personnel with knowledge of pneumatic equipment to maintain Products.
- ② Checkout before maintenance
Before attempting any kind of maintenance, make sure that a product to be worked On is open to atmosphere as cutting power supply, stopping compressed air from Piping.
- ③ Checkout after maintenance
After mounting and/or repair, supply compressed air and power to the equipment and check for proper operation and possible air leak. If the equipment has so Much leak as to make noise or improper operation, stop operating it and verify Mounting.
- ④ Remodeling prohibited.
Do not remodel a product.

2. PURPOSE

This instrument aims at pressure controlling of air line.

3. SPECIFICATIONS

MODEL	ARX20	
REGULATOR CONSTRUCTION	PISTON TYPE REGULATOR	
RELIEF MACHANISM	RELIEF TYPE	
PORT SIZE	Rc (PT) 1/8, 1/4	
GUAGE PORT SIZE	Rc (PT) 1/8, 1/4	
PROOF PRESSURE MPa {kgf/cm ² }	3.0	
MAX. WORKING PRESSURE MPa {kgf/cm ² }	2.0	
SET PRESSURE	LOW PRESSURE TYPE	0.05~0.3 MPa
	STANDARD TYPE	0.05~0.85 MPa
WORKING FLUID	AIR	
AMBIENT & MEDIA TEMPERATURE °C	-5~60	
WEIGHT g	110	

4. HOW TO ORDER

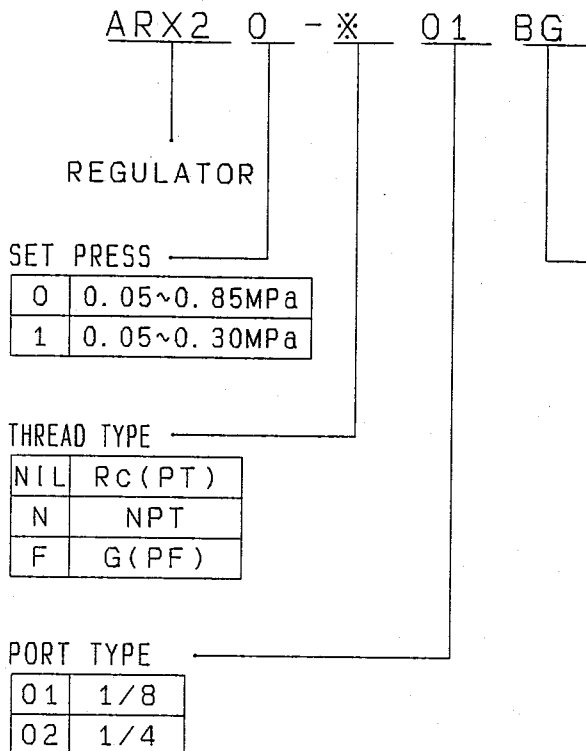

OPTIONS

B	BRACKET	1348112	
G	PRESSURED GAUGE	ARX20-NIL**	G36-10-01 G46-10-02
		ARX21-NIL**	G36-4-01 G46-4-02
		ARX20-N**	G36-P10-N01 G46-P10-N02
		ARX21-N**	G36-P4-N01 G46-P4-N02
P	PANEL NUT	1348110A	

COMBINATION OF OPTIONS

B	BG	*PANEL NUT ATTACHED FOR B
G	GP	
P		

5 . TROUBLESHOOTING

TROUBLE	POSSIBLE CAUSE	REMEDY
Pressure is not regulated.	<ol style="list-style-type: none"> 1. Opposite flow direction or opposite installation of regulator. 2. Broken pressure adjust Spring. 3. Broken valve spring. 4. Foreign materials caught in valve seat. 5. Damaged rubber lining on valve. 	<ol style="list-style-type: none"> 1. Check flow direction, and Install the regulator Correctly if wrong. 2. Replace the adjust spring. 3. Replace the valve spring. 4. Remove bonnet and clean valve seat and valve . 5. Replace the valve.
Set pressure does not return to 0 when pressure regulating handle is loosened.	<ol style="list-style-type: none"> 1. Foreign materials caught in valve seat. 2. Damaged rubber lining on valve. 3. Broken valve spring. 	<ol style="list-style-type: none"> 1. Remove bonnet and clean valve seat and valve. 2. Replace the valve. 3. Replace the valve spring.
Air leaks near handle. (in side of handle)	<ol style="list-style-type: none"> 1. Piston "O" ring is broken Or caught dust. 2. Foreign materials caught in relief seat of valve. 	<ol style="list-style-type: none"> 1. Replace Piston "O" ring or Clean seat and Piston "O" ring. Apply grease to seat and Piston "O" ring after Cleaning. 2. Remove bonnet and clean valve and piston.
Air leaks near bonnet.	<ol style="list-style-type: none"> 1. Loosened bonnet. 2. Piston "O" ring is broken Or caught dust. 	<ol style="list-style-type: none"> 1. Fasten the bonnet evenly. 2. Replace Piston "O" ring or clean seat and piston "O" ring. Apply grease to seat and Piston "O" ring after Cleaning.

6. CONSTRUCTION/PARTS LIST

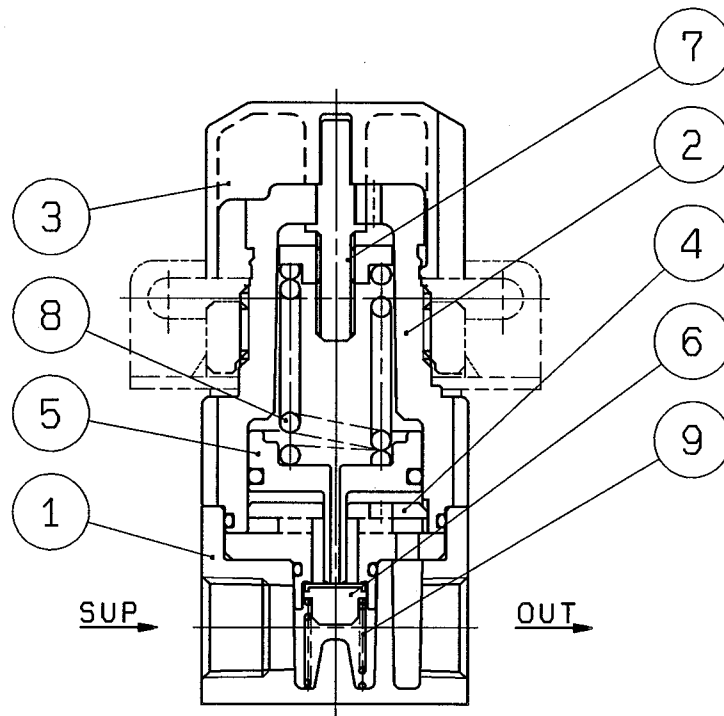

No.	PART NAME
1	BODY
2	BONNET ASSEMBLY
3	HANDLE
4	VALVE SEAT ASSEMBLY
5	PISTON ASSEMBLY
6	VALVE
7	ADJUST SCREW
8	ADJUST SPRING
9	VALVE SPRING

7. SPARE PARTS

A	No.	Description	Material	Part no.
	3	Handle	POM	1348102 #1
	5	Piston assembly	POM · NBR	1348104A
	6	Valve	Brass · NBR	1348114
	8	Adjusting spring	Steel wire	1348108 (For 0.85MP a) 1348108-1 (For 0.3 MP a)
	9	Valve spring	Stainless steel	1348109