



ORIGINAL INSTRUCTIONS



Refer to Declaration of Conformity for relevant Directives

**Instruction Manual**  
**Dual Rod Cylinder**  
**55-CXS(J) Series**

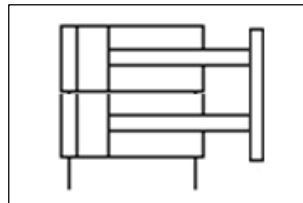
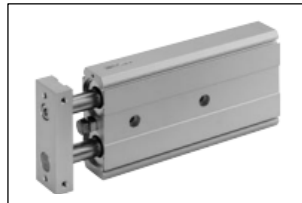

CE Ex II 2GD	Ex h IIC T6/T5 Gb	-10°C ≤ Ta ≤ +60°C
	Ex h IIIC T78°C/T98°C Db	

**ATEX Marking Description:**

Ex	Specific Marking for Explosion Protection
II	Equipment Group
2	Equipment Category
GD	Environment (Gas/Dust)
Ex h	General Protection Level Symbols
IIC	Gas Sub-Division
IIIC	Dust Sub-Division
T	Temp. Classification
Gb/Db	Equipment Protection Level
X	Special Conditions of Use
Ta	Ambient Temperature Range

The intended use of this ATEX Category 2 actuator is to convert the potential energy provided by compressed air into a force which causes mechanical linear motion.

Certificate Number:	SMC19.0042 X
---------------------	--------------

**Note 1:** The X at the end of the certificate number represents that this product is subject to "Special Conditions of Use", please see Section 2.3.

**1 Safety Instructions**

These safety instructions are intended to prevent hazardous situations and/or equipment damage. These instructions indicate the level of potential hazard with the labels of "Caution," "Warning" or "Danger." They are all important notes for safety and must be followed in addition to International Standards (ISO/IEC<sup>1)</sup>, and other safety regulations.

<sup>1)</sup> ISO 4414: Pneumatic fluid power - General rules relating to systems.  
ISO 4413: Hydraulic fluid power - General rules relating to systems.  
IEC 60204-1: Safety of machinery - Electrical equipment of machines. (Part 1: General requirements)  
ISO 10218-1: Manipulating industrial robots -Safety. etc.

- Refer to product catalogue, Operation Manual and Handling Precautions for SMC Products for additional information.
- Keep this manual in a safe place for future reference.

	<b>Caution</b>	Caution indicates a hazard with a low level of risk which, if not avoided, could result in minor or moderate injury.
	<b>Warning</b>	Warning indicates a hazard with a medium level of risk which, if not avoided, could result in death or serious injury.
	<b>Danger</b>	Danger indicates a hazard with a high level of risk which, if not avoided, will result in death or serious injury.

**Warning**

- Always ensure compliance with relevant safety laws and standards.
- All work must be carried out in a safe manner by a qualified person in compliance with applicable national regulations.

**2 Specifications**

This product is certified to ATEX Category 2GD and therefore is suitable for use in Zones 1, 2, 21 and 22 only.

**2.1 Product Specifications:**

Refer to the operation manual for this product;

**2.1.1 Standard CXS Product:**

Fluid	Air	
Max. Operating Pressure	0.7 MPa	
Min. Operating Pressure	Ø 6	0.15 MPa
	Ø 10 ~ Ø 15	0.10 MPa
	Ø 20 ~ Ø 32	0.05 MPa
Ambient & Fluid Temperature	-10°C to +60°C	
Lubrication	Not Required	
Operating Piston Speed	Ø 6	30 to 300 mm/s
	Ø 10	30 to 800 mm/s
	Ø 15 ~ Ø 20	30 to 700 mm/s
	Ø 25 ~ Ø 32	30 to 600 mm/s
Cushion	Rubber Bumper	
Allowable Kinetic Energy	Ø 6	0.002 J
	Ø 10	0.064 J
	Ø 15	0.095 J
	Ø 20	0.170 J
	Ø 25	0.270 J
Ø 32	0.320 J	

**2.1.2 Standard CXSJ Product:**

Fluid	Air	
Max. Operating Pressure	0.7 MPa	
Min. Operating Pressure	Ø 6	0.15 MPa
	Ø 10 ~ Ø 15	0.10 MPa
	Ø 20 ~ Ø 32	0.05 MPa
Ambient & Fluid Temperature	-10°C to +60°C	
Lubrication	Not Required	
Operating Piston Speed	Ø 6 ~ Ø 10	30 to 800 mm/s
	Ø 15 ~ Ø 20	30 to 700 mm/s
	Ø 25 ~ Ø 32	30 to 600 mm/s
Cushion	Rubber Bumper	
Allowable Kinetic Energy	Ø 15	0.095 J
	Ø 20	0.170 J
	Ø 25	0.270 J
	Ø 32	0.320 J

**2.2 Production Batch Code:**

The batch code printed on the label indicates the month and the year of production as per the following table;

		Production Batch Codes											
Year		2017	2018	2019	...	2021	2022	2023	...				
Month		V	W	X	...	Z	A	B	...				
Jan	O	Vo	Wo	Xo	...	Zo	Ao	Bo	...				
Feb	P	VP	WP	XP	...	ZP	AP	BP	...				
Mar	Q	VQ	WQ	XQ	...	ZQ	AQ	BQ	...				
Apr	R	VR	WR	XR	...	ZR	AR	BR	...				
May	S	VS	WS	XS	...	ZS	AS	BS	...				
Jun	T	VT	WT	XT	...	ZT	AT	BT	...				
Jul	U	VU	WU	XU	...	ZU	AU	BU	...				
Aug	V	VV	WV	XV	...	ZV	AV	BV	...				
Sep	W	VW	WW	XW	...	ZW	AW	BW	...				
Oct	X	VX	WX	XX	...	ZX	AX	BX	...				
Nov	Y	Vy	Wy	Xy	...	Zy	Ay	By	...				
Dec	Z	VZ	WZ	XZ	...	ZZ	AZ	BZ	...				

**2.3 Special Conditions of Use:**

- Products are suitable for sub-divisions IIC & IIIC.
- Products are suitable for Zones 1, 2, 21 & 22 only.

**2.3.1 Temperature Marking:**

**2.3.1.1 Standard Product:**

- In the normal ambient temperature range (-10°C to +40°C) the product is rated to temperature class T6 and has a maximum surface temperature of 78°C.
- In the special ambient temperature range (+40°C to +60°C) the product is rated to temperature class T5 and has a maximum surface temperature of 98°C.

**3 Installation**

**3.1 Installation**

**Warning**

- Do not install the product unless the safety instructions have been read and understood.
- Do not twist or bend the cylinder, or mount the product when subject to tension.
- Do not use in an application where the product is stopped mid-stroke, via an external stop.
- Do not use where cylinders are being synchronised to move a single load.
- Mount Directly to the body of the actuator.

**3.2 Environment**

**Warning**

- Do not use in an environment where corrosive gases, chemicals, water, salt water or steam are present.
- Do not use in an explosive atmosphere except within the specified rating.
- Do not expose to direct sunlight. Use a suitable protective cover.
- Do not install in a location subject to vibration or impact in excess of the product's specifications.
- Do not use in a place subject to heavy vibration and/or shock.
- Do not use in wet environments, where water can remove the presence

of the lubrication.

- Do not use in case of heavy dusty environments where dust can penetrate into the cylinder and dry the grease.
- Do not allow dust layers to build up on the cylinder surface and insulate the product.

**3.3 Piping**

**Caution**

- Before connecting piping make sure to clean up chips, cutting oil, dust etc.
- When installing piping or fittings, ensure sealant material does not enter inside the port. When using seal tape, leave 1 thread exposed on the end of the pipe/fitting.
- Tighten fittings to the specified tightening torque.

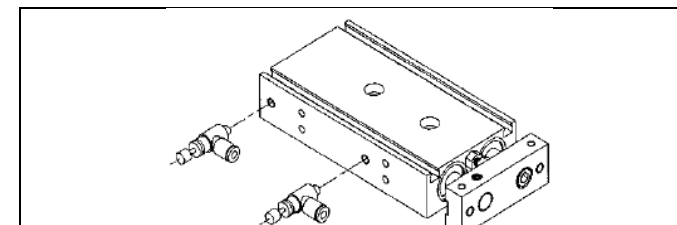

Bore [mm]	Port Size	Bore [mm]	Port Size
CXS Ø6 - Ø20	M5 x 0.8	CXSJ Ø15 - Ø25	M5 x 0.8
CXS Ø25 - Ø32	Rc, [TF], G 1/8	CXSJ Ø32	Rc, TF, G 1/8

**3.4 Lubrication**

**Caution**

- SMC products have been lubricated for life at manufacture, and do not require lubrication in service.
- If a lubricant is used in the system, refer to catalogue for details.

**3.5 Basic Circuit**

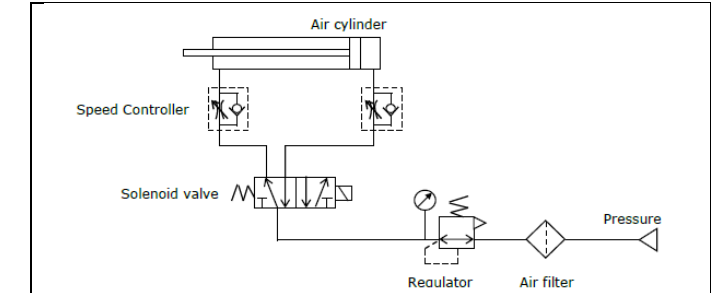

- Plugging one of the ports on the actuator is considered a non-intended use, and could relate to an increase in maximum surface temperature above what the product specification declares.

**3.6 Electrical Connection**

- The product should be grounded by the piston rod and the body in order to create an electrically conductive path to the system/application.
- Ground the product in accordance with applicable regulations.
- Do not pass an electrical current through the product.

**4 Settings**

Refer to the standard product catalogue.

**5 How to Order**

Refer to the standard product catalogue for 'How to Order'.

**6 Outline Dimensions (mm)**

Refer to the standard product catalogue for general dimensions.

**7 Maintenance**

**7.1 General Maintenance**

**Caution**

- Not following proper maintenance procedures could cause the product to malfunction and lead to equipment damage.
- If handled improperly, compressed air can be dangerous.

- Maintenance of pneumatic systems should be performed only by qualified personnel.
- Before performing maintenance, turn off the power supply and be sure to cut off the supply pressure. Confirm that the air is released to atmosphere.
- After installation and maintenance, apply operating pressure and power to the equipment and perform appropriate functional and leakage tests to make sure the equipment is installed correctly.
- If any electrical connections are disturbed during maintenance, ensure they are reconnected correctly and safety checks are carried out as required to ensure continued compliance with applicable national regulations.
- Do not make any modification to the product.
- Do not disassemble the product, unless required by installation or maintenance instructions.
- Do not use a product which looks or contains damage, this will invalidate the certification. If damage is seen, please replace the product immediately.
- Periodically check the product for any damage or rust appearing. This could result in an increase in friction and lead to dangerous conditions. Replace the whole actuator if any of these conditions appear.
- Periodically check the condition of the rod seal and for the presence of lubrication, where possible. If these areas appear to be dry, please follow the lubrication procedure.
- Replace the seals, when air leakage is above the allowable value given in the table below;

	Allowable Leakage
Internal Leakage	10 cm <sup>3</sup> / min (ANR)
External Leakage	5 cm <sup>3</sup> / min (ANR)

**7.2 Disassembly Procedure**

- Disassemble the cylinder, remove the old grease and place all the parts on a clean cloth in a clean environment.
- Remove the O-ring, rod seal and piston seal.

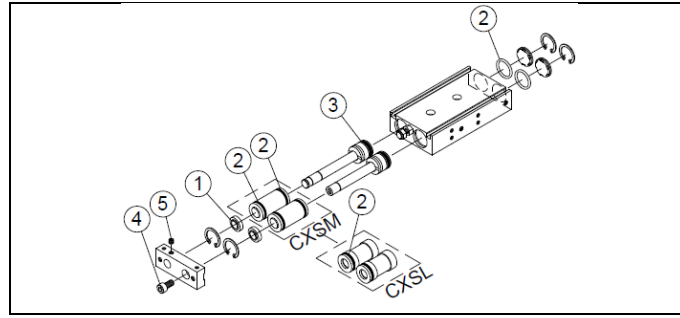

Note 1: CXSJ and CXSJL are similar construction just more compact.

1	Rod Seal	4	Hexagon Socket Head Cap Bolt
2	O-Ring	5	Hexagon Socket Head Set Screw
3	Piston Seal		

### 7.3 Seal Replacement Part Numbers

#### Warning

Only use SMC seal kits as listed in the table below;

Description	Applicable Bore [mm]	Part Number
Standard CXSM (inc. XB11)	∅ 6 ~ ∅ 32	CXSM*-PS
Standard CXSL (inc. XB11)	∅ 6 ~ ∅ 32	CXSL*-PS
CXSM XC22 Option	∅ 6, ∅ 15 ~ ∅ 32	CXSM*-XC22-PS
CXSM XC22 Option	∅ 10	CXSM10AXC22-PS
CXSL XC22 Option	∅ 6	CXSL6-XC22-PS
CXSL XC22 Option	∅ 10	CXSL10BXC22-PS
CXSL XC22 Option	∅ 15 ~ ∅ 32	CXSL*AXC22PS
Standard CXSJM Option	∅ 15 ~ ∅ 32	CXSJM*-PS
Standard CXSJL Option	∅ 15 ~ ∅ 32	CXSJL*APS

Note 4: The \* represents the Bore Size (e.g. ∅25 is 25).

#### Caution

- A wear ring is not fitted to double rod cylinders.

### 7.4 Lubrication Procedure

- Apply lubricant to:
  - The rod seal
  - The rod seal groove on the rod cover.
  - The piston outer surface and piston seal groove.
  - The piston rod surface and cylinder tube internal surface.
- Lubricate the parts with the grease packs provided with the seal kit. For additional grease use the grease pack listed below.

Product	Grease Pack Number	Weight [g]
Standard	GR-S-010	10
	GR-S-020	20

The amount of lubricant to be applied is listed in the following table.

Bore [mm]	Amount of Lubricant [g]
∅ 6	0.3 ~ 0.5
∅ 10	0.5 ~ 1.0
∅ 15	1.0 ~ 1.5
∅ 20	1.5 ~ 2.0
∅ 25	2.0 ~ 2.5
∅ 32	2.5 ~ 3.0

### 7.5 Reassembly Procedure

- Reassembly should be completed in the following order:
  - Head Cover Assembly (In case of CXSJ),
  - Snap Ring on the Head Cover Side,
  - Piston Rod Assembly,
  - Rod Cover Assembly / Ball Pushing Assembly,
  - Snap ring on the Rod Cover side,
  - Plate.
- When assembling the plate, supply air to the cylinder till it is extended.
  - Tighten the hexagon socket head cap bolt first, and then the hexagon socket head set screw.
- Use the following torque for tightening the hexagon socket head cap bolt and hexagon socket head set screw.

Bore Size [mm]	Tightening Torque for Hex. Socket Bolt [Nm]	Tightening Torque for Hex. Socket Screw [Nm]
∅ 6	1.0 ~ 1.5	0.5 ~ 0.8
∅ 10	3.0 ~ 4.0	3.0 ~ 4.0
∅ 15		7.5 ~ 9.0
∅ 20	8.0 ~ 10.0	9.0 ~ 11.0
∅ 25		
∅ 32	12.5 ~ 16.5	19.6 ~ 29.4

- Before re-installing the cylinder back into the machine, check for smooth movement and check for air leakage.

## 8 Limitations of Use

### 8.1 Limited warranty and Disclaimer/Compliance Requirements

Refer to Handling Precautions for SMC Products located on [www.smcworld.com](http://www.smcworld.com).

### 8.2 Obligations of the end-user

- Ensure the product is used within the specification outlined.
- Ensure that the maintenance periods are suitable for the application.
- Ensure any cleaning processes to remove dust layers are made with the atmosphere in mind (e.g. using a damp cloth to avoid static build up).
- Ensure that the application does not introduce additional hazards by mounting, loading, impacts or other methods.
- Ensure that there is sufficient ventilation and air circulation around the product.
- If the product is subject to direct heat sources in the application, they should be shielded so that the actuator temperature stays within the stated operating range.

#### Caution

- SMC products are not intended for use as instruments for legal metrology.**

Measurement instruments that SMC manufactures or sells have not been qualified by type approval tests relevant to the metrology (measurement) laws of each country.

#### Danger

- Do not exceed any of the specifications listed in Section 2 of this document as this will be deemed improper use.
- Air equipment has an air leakage during operation within certain limits. Do not use this equipment when the air itself introduces additional hazards and could lead to an explosion.
- Use only ATEX certified auto switches. These should be ordered separately.
- Do not use this product in the presence of strong magnetic fields that could generate a surface temperature higher than the product specification.
- Avoid applications where the piston rod end and the adjoining part in the application can create a possible ignition source.
- Do not install or use these actuators where there is the possibility for the piston rod to impact foreign objects.
- In the event of damage or failure of any parts located in the vicinity where this product has been installed, it is the responsibility of the user to determine whether or not this has compromised the safety and condition of this product and/or the application.
- External impact on the cylinder body could result in a spark and/or cylinder damage. Avoid any application where foreign objects can hit or impact the cylinder. In such situations the application should install a suitable guard to prevent this occurrence.
- Do not use this equipment where vibration could lead to failure.

## 9 Contacts

Refer to Declaration of Conformity and [www.smcworld.com](http://www.smcworld.com) for contacts.

## SMC Corporation

URL : <http://www.smcworld.com> (Global) <http://www.smceu.com> (Europe)

SMC Corporation, Akihabara UDX15F, 4-14-1, Sotokanda, Chiyoda-ku, Tokyo 101 0021  
 Specifications are subject to change without prior notice from the manufacturer.  
 © 2018 SMC Corporation All Rights Reserved.  
 Template DKP50047-F-085H