

Pressure switch for energy-saving control
Before Use
 ZK2 series



Thank you for purchasing the SMC ZK2 Series with Pressure Switch. Please read the operation manual carefully before operating the product and make sure you understand its capabilities and limitations. Please keep the operation manual handy for future reference.

To obtain the operation manual about this product, please refer to the SMC website (URL <https://www.smcworld.com>) or contact SMC directly.

Safety Instructions

These safety instructions are intended to prevent hazardous situations and/or equipment damage. These instructions indicate the level of potential hazard with the labels of "Caution", "Warning" or "Danger". They are all important notes for safety and must be followed in addition to International standards (ISO/IEC) and other safety regulations. To obtain operating the ejector which is mounted on this product, please refer to "Handling Precautions for SMC Products" for vacuum equipment on our general product catalogue or precaution for each product.

- Caution:** Operator error could result in injury or equipment damage.
 - Warning:** Operator error could result in serious injury or loss of life.
 - Danger:** In extreme conditions, there is a possibility of serious injury or loss of life.
- Operator**
- This operation manual is intended for those who have knowledge of machinery using pneumatic equipment, and have sufficient knowledge of assembly, operation and maintenance of such equipment. Only those persons are allowed to perform assembly, operation and maintenance. Read and understand this operation manual carefully before assembling, operating or providing maintenance to the product.

Safety Instructions

- Warning**
- Do not disassemble, modify (including changing the printed circuit board) or repair. An injury or failure can result.
 - Do not use the product except for energy-saving control ejector. Fire, malfunction, or damage to the product or the system can result.
 - Do not operate the product outside of the specifications. Do not use for flammable or harmful fluids. Fire, malfunction, or damage to the product can result. Verify the specifications before use.
 - Do not operate in an atmosphere containing flammable or explosive gases. Fire or an explosion can result. This product is not designed to be explosion proof.
 - Do not use the product in a place where static electricity is a problem. Otherwise it can cause failure or malfunction of the system.
 - If using the product in an interlocking circuit:
 - Provide a double interlocking system, for example a mechanical system
 - Check the product regularly for proper operation
 Otherwise malfunction can result, causing an accident.
 - The following instructions must be followed during maintenance:
 - Turn off the power supply
 - Stop the air supply, exhaust the residual pressure and verify that the air is released before performing maintenance.
 Otherwise an injury can result.
 - Verify the system sufficiently before judging the applicability when a permeable workpiece is to be sucked. Rapid decrease in vacuum pressure during suction of the workpiece may cause the ejector to fail to restart in time, causing injury or damage to the system because of the suction failure.
- Caution**
- Do not touch the terminals and connectors while the power is on. Otherwise electric shock, malfunction or damage to the product can result.
 - Perform sufficient trial run. Otherwise, injury or damage to the system can result due to suction failure depending on the conditions of the suction of the workpiece or the pressure switch settings. Perform sufficient verification before using this product.
 - After maintenance is complete, perform appropriate functional inspections and leak tests. Stop operation if the equipment does not function properly or there is a leakage of fluid. When leakage occurs from parts other than the piping, the product might be faulty. Disconnect the power supply and stop the fluid supply. Do not apply fluid under leaking conditions. Safety cannot be assured in the case of unexpected malfunction.

Names and Functions of Product

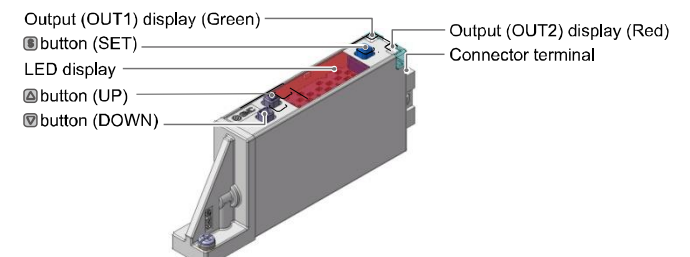

Output (OUT1) display (Green): LED is ON when the switch output (OUT1) is turned ON.
 Output (OUT2) display (Red): LED is ON when the supply pilot valve is ON.
 LED display: Displays the current status of pressure, setting mode and error code.
 button (SET): Selects the mode or increases the ON/OFF set value.
 button (UP): Press this button to change to the peak display mode.
 button (DOWN): Selects the mode or decreases the ON/OFF set value.
 Press this button to change to the bottom display mode.

Installation/Exchange

- Wiring**
- Connection
 - Connections should only be made with the power supply turned off.
 - Use a separate routes for the Pressure switch wiring and any power or high voltage wiring. Otherwise, malfunction may result due to noise.
 - Ensure that the FG terminal is connected to ground when using a commercially available switch-mode power supply. When a switch-mode power supply is connected to the product, switching noise will be superimposed and the product specification can no longer be met. This can be prevented by inserting a noise filter, such as a line noise filter and ferrite core, between the switch-mode power supply and the product, or by using a series power supply instead of a switch-mode power supply.
 - Connector
 - Connecting/Disconnecting
 - When mounting the connector, insert it straight into the socket, holding the lever and connector body, and fit the hook of the lever into the groove in the housing to lock.
 - When removing the connector, press down the lever to release the hook from the groove and pull the connector straight out.

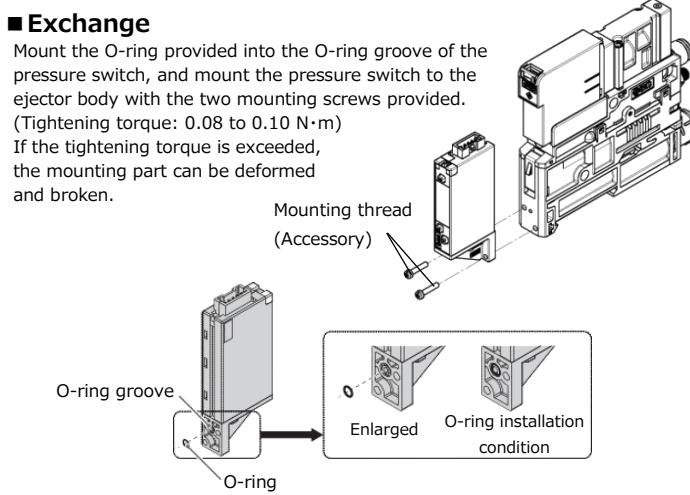
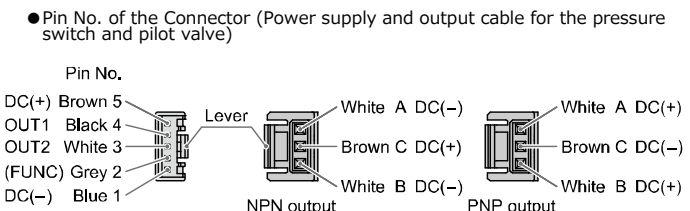
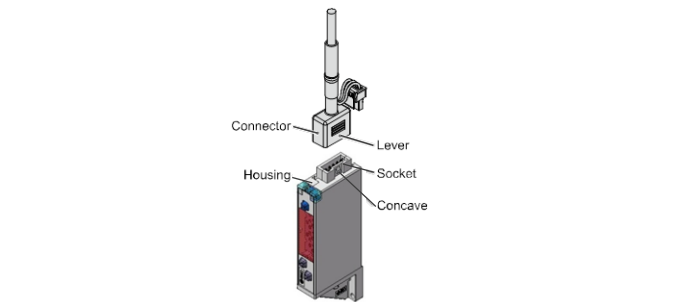

Internal circuit and wiring example

NPN output type
 NPN open collector 2 outputs, Max. applied voltage 26.4 VDC, Max. load current 80 mA
 Residual voltage 2 V or less

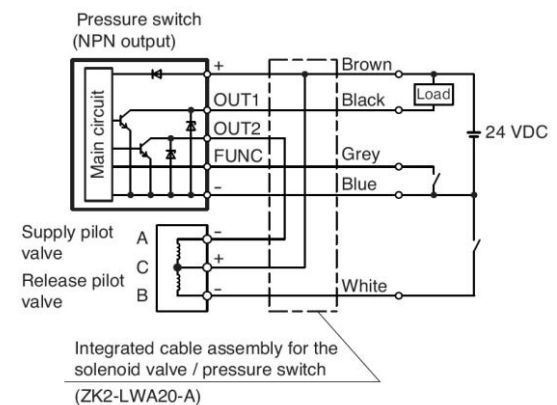

PNP output type
 PNP open collector 2 outputs, Max. load current 80 mA, Residual voltage 2 V or less

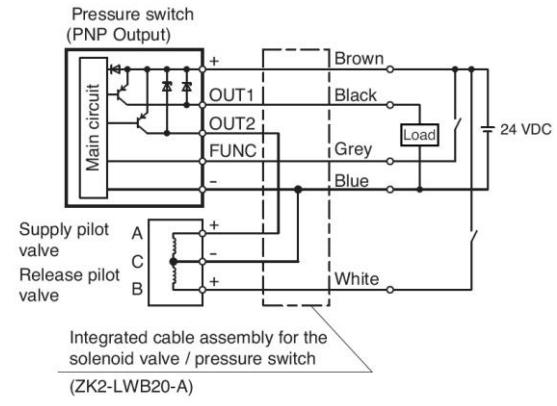

Easy setting

See below for the energy saving control operation and the set values which are preset to the switch. If the operation shown below does not cause any problems, keep these setting.

Operation of OUT1
 When the pressure exceeds the set value (P_1), the pressure switch turns ON. When the pressure decreases below the set value (P_1) by the hysteresis value (H_1), the switch turns OFF. The default settings are P_1: -70.0 kPa and H_1:10.0 kPa.

Operation of OUT2
 Supply pilot valve: OUT2 is turned on by the signal for suction. Suction starts by the generation of vacuum pressure. When the vacuum pressure reaches the set value (P_1), the supply pilot valve turns OFF. After the supply pilot valve is turned off, the vacuum pressure will decrease, when the vacuum pressure drops below (P_1) by the amount set in (P_2) the supply pilot valve will turn on again and increase vacuum pressure. After that, supply pilot valve will turn ON and OFF repeatably. Default setting is H_2: 5.0 kPa.

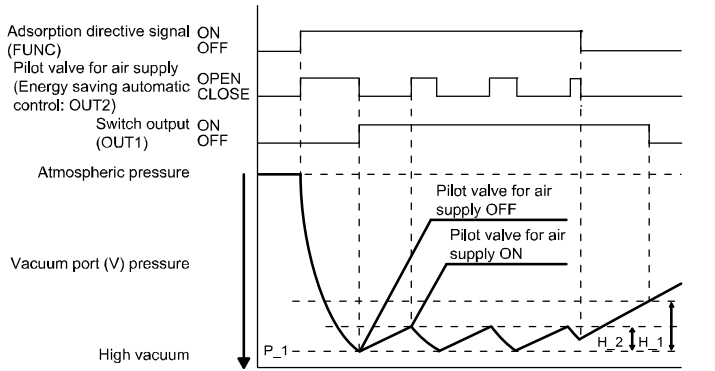

∴ When turning off the supply pilot valve with a vacuum pressure which is higher than the set value (P_1), and other setting methods, refer to the operation manual which can be obtained from the SMC website (URL <https://www.smcworld.com>).

<How to change the set value>
 [Normal output (OUT1)]

- (1) Press the button once in measurement mode.
- (2) "P_1" and the set value are displayed alternately.
- (3) Press the button or button to change the set value. The button is to increase vacuum pressure and the button is for decrease.
- Press the button once to increase the value by one digit, press and hold to continuously increase.
- Press the button once to decrease the value by one digit, press and hold to continuously decrease.
- (4) Press the button to complete the setting of "P_1". The display shows [H_1] and the set value alternately. The button is to increase and the button is to decrease the set value.
- (5) Press the button to complete the setting of "H_1". The display shows [H_2] and the set value alternately. The button is to increase and the button is to decrease the set value.

Function Setting

(6) Press the button to complete the setting.

When the reversed output is changed, the following parameters are displayed, and each set value can be changed, using the method shown above.

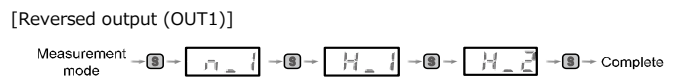

Measurement mode

The measurement mode is the condition where the pressure is detected and indicated, and the switch function is operating. This is the basic mode, and other modes should be selected for setting change and other function setting changes.

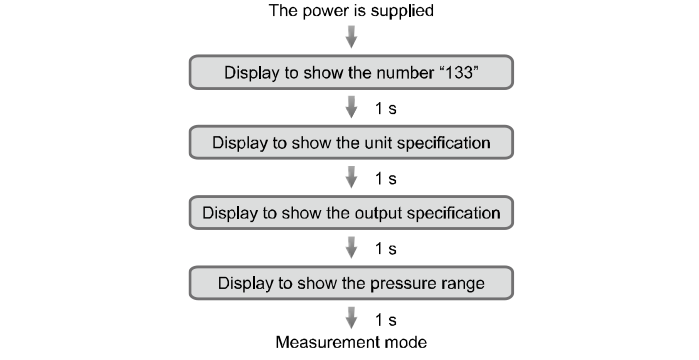

Function selection mode

In measurement mode, press the **[F]** button for 2 seconds or longer to display [F 0]. Select to display the function setting to be changed, [F□□]. Press the **[F]** button for 2 seconds or longer in function selection mode to return to measurement mode.

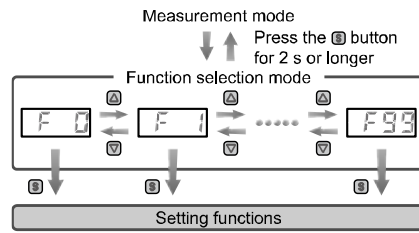

Default setting

The default settings are as follows. Refer to the operation manual on the SMC website (URL <https://www.smcworld.com>) when changing the settings.

●[F 0] Unit conversion function

Unit specification	Default setting
SI unit fixed	kPa
Unit conversion function	

●[F 1] Setting of OUT1

Item	Explanation	Default setting
Reversed output	Selects which type of switch output is used, normal or reversed.	Normal output
Pressure setting	Sets the ON or OFF point of the switch output.	-70 kPa (P_1)
Hysteresis	Setting of hysteresis can prevent chattering.	10 kPa (H_1)

●[F 2] Setting of OUT2

Item	Explanation	Default setting
Supply pilot valve at signal ON	Sets the ON point of the supply pilot valve signal.	5 kPa (H_2)
Supply pilot valve at signal OFF	Sets the OFF point of the supply pilot valve signal.	0 kPa (H_3)
Set the range in which the supply pilot valve input is prohibited	Sets the range where the ON point of the supply pilot valve signal is not allowed to be input.	1 kPa (H_4)

●[F 3] to [F99] Setting

Item	Default setting
[F 3] Setting of response time	2.5 ms
[F 4] Setting of auto-preset	Manual
[F 6] Setting of fine adjustment of display value	0%
[F11] Setting of display resolution	1000-split
[F80] Setting of power saving mode	OFF
[F81] Setting of security code	OFF
[F90] Setting of all functions	OFF
[F96] Checking of suction command condition	OFF
[F98] Check of output	Normal
[F99] Reset to the default setting	OFF

■ [F99] Reset to the default setting

If the setting of the pressure switch becomes unknown, the default setting can be restored.

<Operation>

Press the **[F]** or **[V]** button in function selection mode to display [F99]. Press the **[F]** button. **↓** Move on to reset to the default setting.

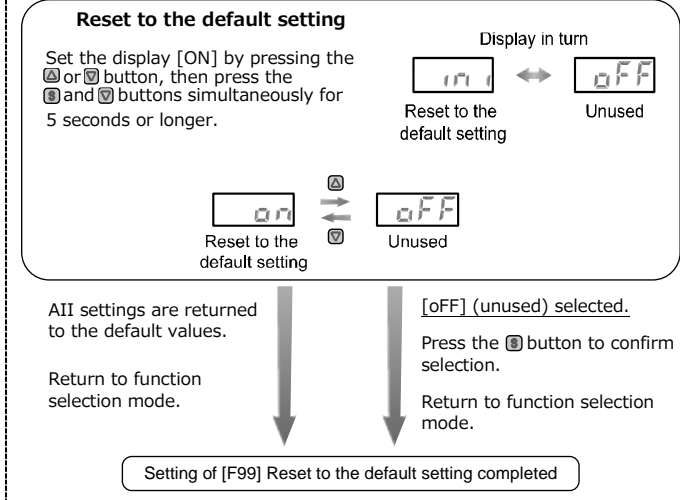

Other Settings

- Peak/Bottom hold value indication
- Zero clear

Zero clear of indication

Indication is reset to zero when **[A]** and **[V]** buttons are pressed simultaneously for 1 second. For the first operation, perform zero clear without pressure supply.

○Key lock

Refer to the operation manual on the SMC website (URL <https://www.smcworld.com>) for the settings shown above.

Maintenance

How to reset the product for power cut or forcible de-energizing

The setting of the product will be retained as it was before a power cut or de-energizing. The output condition is also basically recovered to that before a power cut or de-energizing, but may change depending on the operating environment. Therefore, check the safety of the whole system before operating the product. If the system is using accurate control, wait until it has warmed up. (Approximately 10 minutes)

Model indication Method

How to order

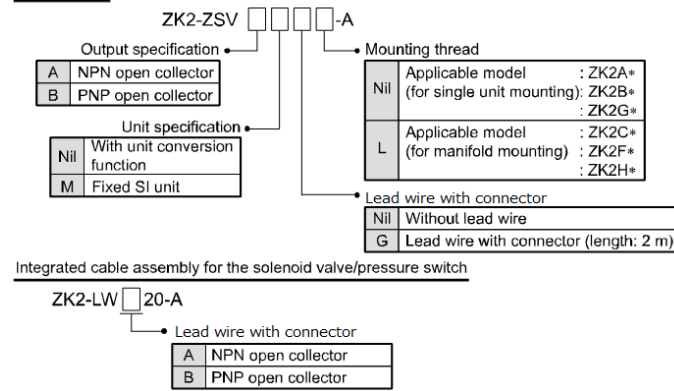

Troubleshooting

■ Error indication

This function is to display error location and content when a problem or an error occurs.

Error Name	Error Display	Error Type	Troubleshooting Method
Over current Error	Er 1 Er 2	The switch output load current is more than 80 mA.	Turn the power off and remove the cause of the over current. Then turn the power on.
Zero-clear Error	Er 3	During the zero clear operation, pressure above $\pm 3.5\%$ F.S. has been applied. After 1 second, the mode will return to measurement mode. The zero clear range can vary $\pm 1\%$ F.S. with individual product differences.	Perform zero clear operation again after restoring the applied pressure to an atmospheric pressure condition.
Pressurizing Error	HHH	Pressure has exceeded the upper limit of the set pressure range.	Reset applied pressure to a level within the set pressure range.
	LLL	Pressure has exceeded the lower limit of the set pressure range.	
System Error	Er 0 Er 4 Er 6 Er 7 Er 8 Er 9	Displayed in the case of an internal data error.	Turn the power off and turn it on again. If resetting fails, an investigation by SMC Corporation will be required.

If the error can not be reset after the above measures are taken, then please contact SMC.

Specification

Refer to the operation manual on the SMC website (URL <https://www.smcworld.com>).

SMC Corporation

URL <https://www.smcworld.com>

Akihabara UDX 15F, 4-14-1, Sotokanda, Chiyoda-ku, Tokyo 101-0021, JAPAN

Phone: +81 3-5207-8249 Fax: +81 3-5298-5362

Note: Specifications are subject to change without prior notice and any obligation on the part of the manufacturer.

© 2019-2022 SMC Corporation All Rights Reserved

ZK2-OM01001-A